

Basic User's Guide

MFC-J6520DW
MFC-J6720DW

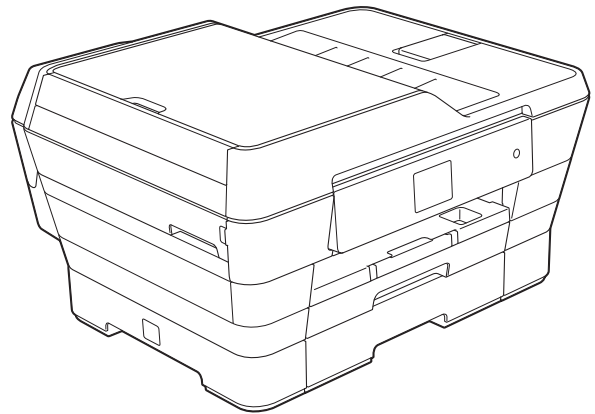

If you need to contact Customer Service

Please complete the following information for future reference:

**Model Number: MFC-J6520DW and MFC-J6720DW
(Circle your model number)**

Serial Number: ¹ _____

Date of Purchase: _____

Place of Purchase: _____

¹ The serial number is on the back of the unit. Retain this User's Guide with your sales receipt as a permanent record of your purchase, in the event of theft, fire or warranty service.

Register your product on-line at

<http://www.brother.com/registration/>

User's Guides and where do I find them?

Which Guide?	What's in it?	Where is it?
Product Safety Guide	Read this Guide first. Please read the Safety Instructions before you set up your machine. See this Guide for trademarks and legal limitations.	Printed / In the box
Quick Setup Guide	Follow the instructions for setting up your machine, and installing the drivers and software for the operating system and connection type you are using.	Printed / In the box
Basic User's Guide	Learn the basic Fax, Copy, Scan and PhotoCapture Center™ operations and how to replace consumables. See troubleshooting tips.	Printed / In the box ¹
Advanced User's Guide	Learn more advanced operations: Fax, Copy, security features, printing reports and performing routine maintenance.	PDF file / CD-ROM
Software and Network User's Guide	This Guide provides instructions for Scanning, Printing, PC-Fax and other operations that can be performed by connecting your Brother machine to a computer. You can also find useful information about using the Brother ControlCenter utility, using your machine in a network environment, and frequently used terms.	HTML file / CD-ROM
Web Connect Guide	This Guide provides useful information about accessing Internet services from the Brother machine, as well as downloading images, printing data and uploading files directly to Internet services.	PDF file / Brother Solutions Center ²
AirPrint Guide	This Guide provides information for using AirPrint to print from OS X v10.7.x, 10.8.x and your iPhone, iPod touch, iPad, or other iOS device to your Brother machine without installing a printer driver.	PDF file / Brother Solutions Center ²
Google Cloud Print Guide	This Guide provides details on how to use Google Cloud Print™ services for printing over the Internet.	PDF file / Brother Solutions Center ²
Wi-Fi Direct™ Guide	This Guide provides details on how to configure and use your Brother machine for wireless printing directly from a mobile device supporting the Wi-Fi Direct™ standard.	PDF file / Brother Solutions Center ²
Mobile Print/Scan Guide for Brother iPrint&Scan	This Guide provides useful information about printing from your mobile device and scanning from your Brother machine to your mobile device when connected to a Wi-Fi network.	PDF file / Brother Solutions Center ²

¹ This may differ depending on your country.

² Visit us at <http://solutions.brother.com/>.

Table of Contents

(Basic User's Guide)

1	General information	1
	Using the documentation	1
	Symbols and conventions used in the documentation	1
	Accessing Brother Utilities (Windows® 8)	1
	Accessing the Advanced User's Guide and Software and Network User's Guide	2
	Viewing User's Guides	2
	How to access Guides for Advanced Features	4
	Accessing Brother Support (Windows®)	4
	Accessing Brother Support (Macintosh)	5
	Control panel overview	6
	2.7"(67.5 mm) Touchscreen LCD	8
	Basic Operations	11
	Changing the keyboard setting	12
	Shortcut Settings	12
	Adding Copy Shortcuts	12
	Adding Fax Shortcuts	13
	Adding Scan Shortcuts	14
	Adding Web Connect Shortcuts	15
	Changing Shortcuts	16
	Editing Shortcut Names	17
	Deleting Shortcuts	17
	Recalling Shortcuts	17
	Volume Settings	18
	Ring Volume	18
	Beeper Volume	18
	Speaker Volume	19
	Touchscreen LCD	19
	Setting the Backlight brightness	19
2	Loading paper	20
	Loading paper and other print media	20
	Loading paper in paper tray #1	20
	Loading smaller paper (Photo, Photo L, Photo 2L or envelopes)	25
	Loading paper in paper tray #2 (MFC-J6720DW)	28
	Loading paper in the manual feed slot	33
	Unprintable area	36
	Paper settings	37
	Paper Type (MFC-J6520DW)	37
	Paper Size (MFC-J6520DW)	37
	Paper Size and Type (MFC-J6720DW)	37
	Tray use in Copy mode (MFC-J6720DW)	38
	Tray use in Fax mode (MFC-J6720DW)	39

	Acceptable paper and other print media.....	39
	Recommended print media	40
	Handling and using print media	40
	Choosing the right print media.....	41
3	Loading documents	44
	How to load documents	44
	Using the ADF	44
	Using the scanner glass	45
	Unscannable area	46
4	Sending a fax	47
	How to send a fax.....	47
	Stop faxing.....	48
	Setting scanner glass size for faxing	49
	Colour fax transmission	49
	Cancelling a fax in process.....	49
	How to preview an outgoing fax	50
	Transmission Verification Report.....	51
5	Receiving a fax	52
	Receive Modes	52
	Choose the Receive Mode	52
	Using Receive Modes	54
	Fax Only	54
	Fax/Tel.....	54
	Manual.....	54
	External TAD	54
	Receive Mode settings	55
	Ring Delay	55
	F/T Ring Time (Fax/Tel mode only).....	55
	Fax Detect	56
	Fax Preview (Monochrome faxes only)	57
	How to preview a received fax.....	57
	Turning off Fax Preview.....	59
6	Using PC-FAX	60
	PC-FAX Sending	60
	Sending a file as a PC-FAX.....	60
	PC-FAX Receiving (Windows®).....	61

7	Telephone and external devices	63
	Voice operations	63
	Fax/Tel mode.....	63
	Caller ID (U.K. and Ireland only).....	63
	Telephone services.....	64
	Setting the Telephone Line Type.....	64
	Voice over Internet Protocol (VoIP)	65
	Connecting an external TAD (telephone answering device).....	66
	Connection settings	66
	Recording an outgoing message (OGM) on an external TAD	67
	Multi-line connections (PBX)	67
	External and extension telephones.....	67
	Connecting an external or extension telephone	67
	Operation from external and extension telephones.....	68
	Using extension telephones (U.K. only)	68
	Using remote codes.....	69
8	Dialling and storing numbers	71
	How to dial	71
	Manual dialling.....	71
	Dialling from the Address Book	71
	Fax Redial	72
	Additional Dialling Operations.....	72
	Outgoing Call history	72
	Caller ID history	73
	Storing numbers	74
	Storing a pause	74
	Storing Address Book numbers.....	74
	Changing or deleting Address Book names or numbers	75
9	Making copies	76
	How to copy	76
	Stop copying	76
	Copy options.....	77
	Paper Type	77
	Paper Size	77
	Tray Select (MFC-J6720DW)	78
	ADF High Speed Mode copying	78
10	Printing photos from a memory card or USB Flash drive	79
	PhotoCapture Center™ operations (PHOTO mode)	79
	Using a memory card or USB Flash drive	79
	Getting started	80
	Print Images.....	82
	View Photos.....	82
	PhotoCapture Center™ print settings.....	83
	How to scan to a memory card or USB Flash drive.....	83

11	How to print from a computer	85
	Printing a document.....	85
12	How to scan to a computer	86
	Before scanning.....	86
	Scanning a document as a PDF file using ControlCenter4 (Windows®)	87
	How to change the machine's SCAN mode settings for PDF scanning	90
	How to scan a document as a PDF file using the Touchscreen	92
	ADF High Speed Mode scanning	93
A	Routine maintenance	94
	Replacing the ink cartridges	94
	Cleaning and checking the machine	97
	Cleaning the scanner glass	97
	Cleaning the print head	98
	Checking the print quality	98
	Checking the print alignment.....	100
	Setting the date and time.....	101
B	Troubleshooting	102
	Identifying your problem	102
	Error and maintenance messages.....	104
	Error animations	114
	Transferring your faxes or Fax Journal report	114
	Document jam	115
	Printer jam or paper jam	117
	If you are having difficulty with your machine	123
	Dial Tone detection.....	135
	Telephone line interference / VoIP	135
	Machine Information	136
	Checking the serial number.....	136
	Checking the firmware version	136
	Reset functions.....	136
	How to reset the machine.....	137
C	Settings and feature tables	138
	Using the Settings tables	138
	Settings tables	139
	Feature tables.....	158
	Entering Text	186
	Inserting spaces	186
	Making corrections	186

D Specifications 187

General 187
Print media..... 189
Fax..... 191
Copy 192
PhotoCapture Center™ 193
PictBridge 194
Scanner 195
Printer 196
Interfaces 197
Network..... 198
Computer requirements 199
Consumable items 200

E Index 201

Table of Contents

(Advanced User's Guide)

The Advanced User's Guide explains the following features and operations.

You can view the Advanced User's Guide on the CD-ROM.

1 General setup

Memory Storage
Automatic Daylight Saving Time
Sleep Mode
Touchscreen LCD

2 Security features

Secure Function Lock 2.0
Restricting dialling

3 Sending a fax

Additional sending options
Additional sending operations
Polling

4 Receiving a fax

Memory Receive (Monochrome only)
Remote Retrieval
Additional receiving operations
Polling

5 Dialling and storing numbers

Voice operations
Additional dialling operations
Additional ways to store numbers

6 Printing reports

Fax reports
Reports

7 Making copies

Copy options
A3 Copy Shortcuts

8 Printing photos from a memory card or USB Flash drive

PhotoCapture Center™ operations
Print Images
PhotoCapture Center™ print settings
Scan to a memory card or USB Flash drive

9 Printing photos from a camera

Printing photos directly from a PictBridge camera
Printing photos directly from a digital camera (without PictBridge)

A Routine maintenance

Cleaning and checking the machine
Packing and shipping the machine

B Glossary

C Index

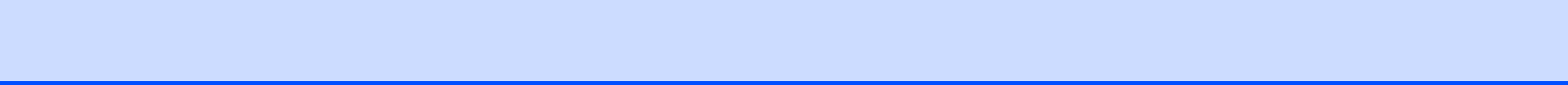

Using the documentation

Thank you for buying a Brother machine! Reading the documentation will help you make the most of your machine.

Symbols and conventions used in the documentation

The following symbols and conventions are used throughout the documentation.

Bold	Bold typeface identifies the dial pad numbers of the Touchpanel and buttons on your computer screen.
<i>Italics</i>	Italicized typeface emphasizes an important point or refers you to a related topic.
<code>Courier New</code>	Text in the Courier New font identifies messages on the Touchscreen of the machine.

WARNING

WARNING indicates a potentially hazardous situation which, if not avoided, could result in death or serious injuries.

CAUTION

CAUTION indicates a potentially hazardous situation which, if not avoided, may result in minor or moderate injuries.

IMPORTANT

IMPORTANT indicates a potentially hazardous situation which, if not avoided, may result in damage to property or loss of product functionality.

NOTE

Notes tell you how to respond to a situation that may arise or give tips about how the operation works with other features.



Electrical Hazard icons alert you to possible electrical shocks.

Accessing Brother Utilities (Windows® 8)

If you are using a tablet or computer running Windows® 8, you can make your selections either by tapping the screen or by clicking with your mouse.

After the printer driver is installed,



Brother Utilities appears on both the Start screen and the desktop.

- 1 Tap or click **Brother Utilities** either on the Start screen or the desktop.

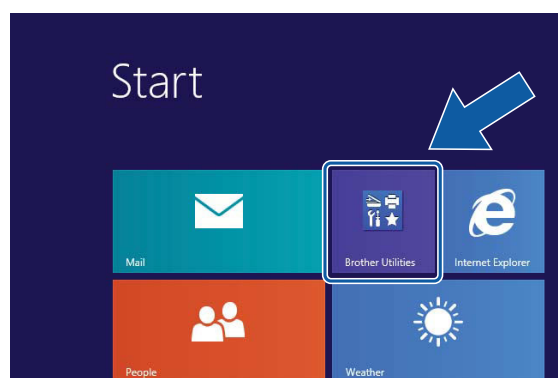

- 2 Select your machine.

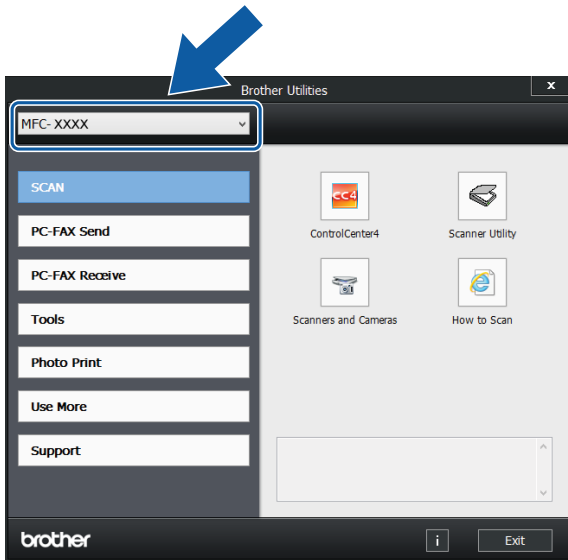

- 3 Choose the function you want to use.

Accessing the Advanced User's Guide and Software and Network User's Guide

This Basic User's Guide does not contain all the information about the machine, such as how to use the advanced Fax, Copy, PhotoCapture Center™, Printer, Scanner, PC-Fax, and Network features. When you are ready to learn detailed information about these operations, you can read the **Advanced User's Guide** and **Software and Network User's Guide** in HTML format that are on the CD-ROM.

Viewing User's Guides

(Windows®)

(Windows® XP/Windows Vista®/Windows® 7/Windows Server® 2003/Windows Server® 2008/Windows Server® 2008 R2)

To view the documentation, from



(Start), **All Programs**, select **Brother**, **MFC-XXXX** (where XXXX is your model name) from the programs list, and then choose **User's Guides**.

(Windows® 8/Windows Server® 2012)



Click **(Brother Utilities)**, and then click the drop-down list and select your model name (if not already selected). Click **Support** in the left navigation bar, and then click **User's Guides**.

If you have not installed the software, you can find the documentation on the CD-ROM by following the instructions below:

- 1 Turn on your PC. Insert the Brother CD-ROM into your CD-ROM drive.

NOTE

If the Brother screen does not appear, go to **Computer** or **My Computer**. (For Windows® 8 and Windows Server® 2012:



Click **(File Explorer)** on the

taskbar, and then go to **Computer**.)

Double-click the CD-ROM icon, and then double-click **start.exe**.

- 2 If the model name screen appears, click your model name.

- 3 If the language screen appears, click your language. The CD-ROM **Top Menu** will appear.

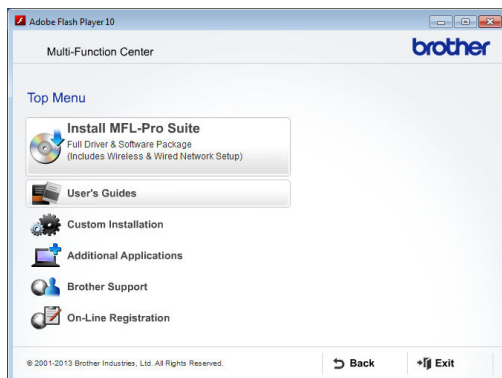

- 4 Click **User's Guides**.
- 5 Click **PDF/HTML documents**. If the country screen appears, choose your country. After the list of User's Guides appears, choose the guide you want to read.

(Macintosh)

- 1 Turn on your Macintosh. Insert the Brother CD-ROM into your CD-ROM drive. The following window will appear.



- 2 Double-click the **User's Guides** icon.
- 3 Select your model and language if needed.
- 4 Click **User's Guides**. If the country screen appears, choose your country.
- 5 After the list of User's Guides appears, choose the Guide you want to read.

How to find Scanning instructions

There are several ways you can scan documents. You can find the instructions as follows:

Software and Network User's Guide

- *Scan*
- *ControlCenter*

Nuance™ PaperPort™ 12SE How-to-Guides (Windows®)

- The complete Nuance™ PaperPort™ 12SE How-to-Guides can be viewed from the Help section in the PaperPort™ 12SE application.

Presto! PageManager User's Guide (Macintosh)

NOTE

Presto! PageManager must be downloaded and installed before use. For more information, see *Accessing Brother Support (Macintosh)* on page 5.

- The complete Presto! PageManager User's Guide can be viewed from the Help section in the Presto! PageManager application.

How to find Network setup instructions

Your machine can be connected to a wireless or wired network.

- Basic setup instructions (See Quick Setup Guide.)
- The wireless access point or router supports Wi-Fi Protected Setup™ or AOSS™ (See Quick Setup Guide.)
- More information about network setup (See Software and Network User's Guide.)

How to access Guides for Advanced Features

You can view and download these Guides from the Brother Solutions Center at: <http://solutions.brother.com/>.

Click **Manuals** on your model's page to download the documentation.

Web Connect Guide

This Guide provides useful information about accessing Internet services from the Brother machine, as well as downloading images, printing data and uploading files directly to Internet services.

AirPrint Guide

This Guide provides information for using AirPrint to print from OS X v10.7.x, 10.8.x and your iPhone, iPod touch, iPad, or other iOS device to your Brother machine without installing a printer driver.

Google Cloud Print Guide

This Guide provides details on how to use Google Cloud Print™ services for printing over the Internet.

Wi-Fi Direct™ Guide

This Guide provides details on how to configure and use your Brother machine for wireless printing directly from a mobile device supporting the Wi-Fi Direct™ standard.

Mobile Print/Scan Guide for Brother iPrint&Scan

This Guide provides useful information about printing from your mobile device and scanning from your Brother machine to your mobile device when connected to a Wi-Fi network.

Accessing Brother Support (Windows®)

You can find all the contacts you will need, such as Web support (Brother Solutions Center) on the CD-ROM.

- Click **Brother Support** on the **Top Menu**. The following screen will appear:

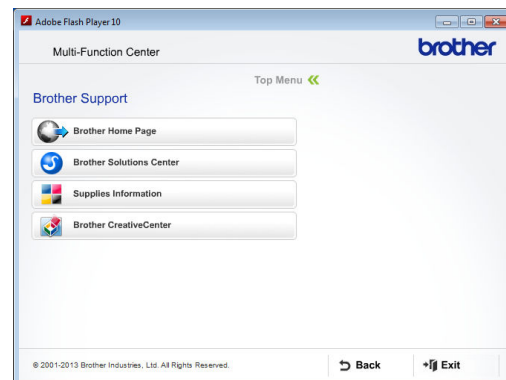

- To access our website (<http://www.brother.com/>), click **Brother Home Page**.
- For the latest news and product support information (<http://solutions.brother.com/>), click **Brother Solutions Center**.
- To visit our website for original Brother Supplies (<http://www.brother.com/original/>), click **Supplies Information**.
- To access the Brother CreativeCenter (<http://www.brother.com/creativecenter/>) for FREE photo projects and printable downloads, click **Brother CreativeCenter**.
- To return to the top menu, click **Back** or if you have finished, click **Exit**.

Accessing Brother Support (Macintosh)

You can find all the contacts you will need, such as Web support (Brother Solutions Center) on the CD-ROM.

- Double-click the **Brother Support** icon. The following screen will appear:



- To download and install Presto! PageManager, click **Presto! PageManager**.
- To access the Brother Web Connect page, click **Brother Web Connect**.
- To register your machine from the Brother Product Registration Page (<http://www.brother.com/registration/>), click **On-Line Registration**.
- For the latest news and product support information (<http://solutions.brother.com/>), click **Brother Solutions Center**.
- To visit our website for original Brother Supplies (<http://www.brother.com/original/>), click **Supplies Information**.

Control panel overview

The MFC-J6520DW and MFC-J6720DW have the same 2.7"(67.5 mm) Touchscreen LCD and Touchpanel.

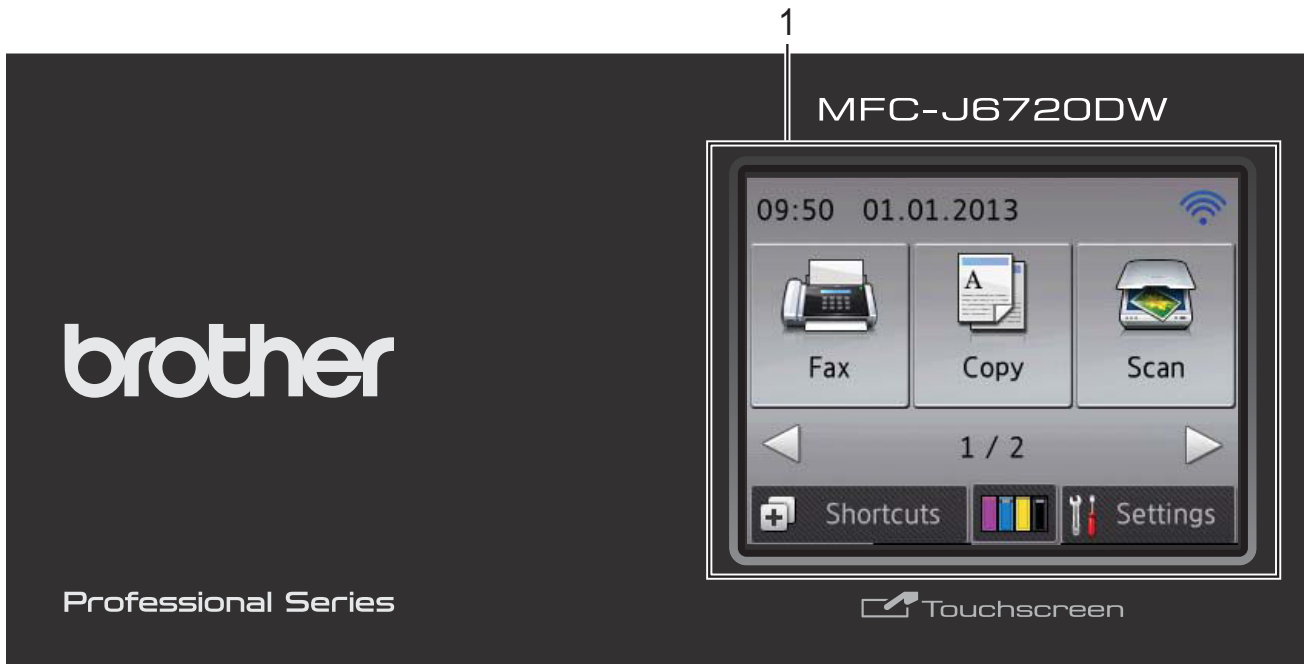

NOTE

Most of the illustrations in this User's Guide show the MFC-J6720DW.

1 2.7"(67.5 mm) Touchscreen LCD (Liquid Crystal Display)

This is a Touchscreen LCD. You can access the menus and options by pressing them as they are displayed on this screen.

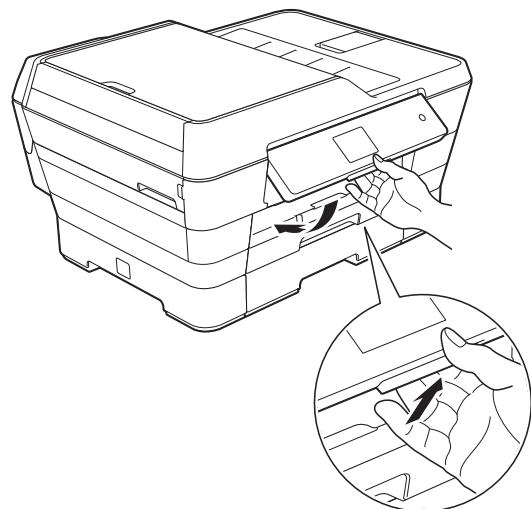

You can adjust the angle of the Touchscreen LCD and Touchpanel by lifting it. To lower this control panel, push the release button that is located behind the control panel, as shown in the illustration.

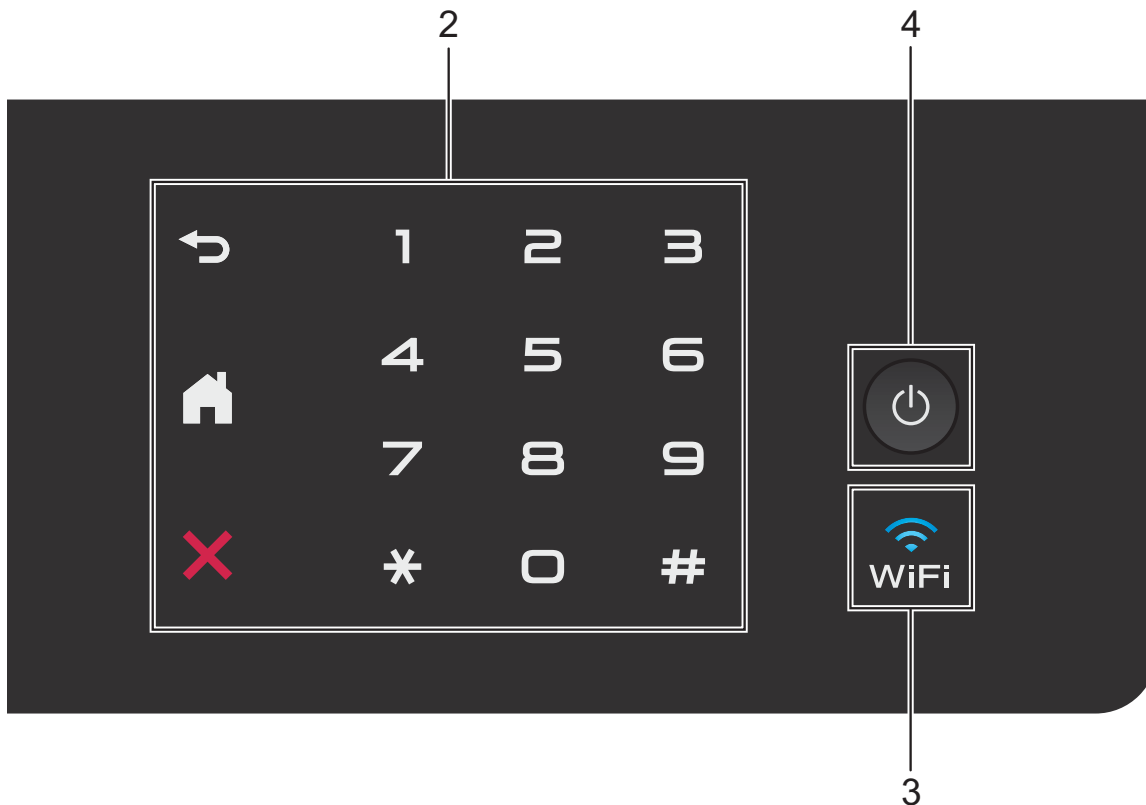



2 Touchpanel:

The LEDs on the Touchpanel only light up when they are available for use.

-  **Back**
Press to go back to the previous menu level.
-  **Home**
Press to return to the Home screen.
-  **Cancel**
Press to cancel an operation when lit.
- **Dial Pad**
Press the numbers on the Touchpanel to dial telephone or fax numbers and to enter the number of copies.

3

The WiFi light is on when the network interface is set to WLAN.

4 Power On/Off

Press  to turn on the machine.

Press and hold down  to turn off the machine. The Touchscreen LCD will show *Shutting Down* and will stay on for a few seconds before turning off.



If you have connected an external telephone or TAD, it is always available for use.

If you turn off the machine using , it will still periodically clean the print head to maintain print quality. To prolong the life of the print head, provide better ink efficiency and maintain print quality, you should keep your machine connected to the power at all times.

2.7"(67.5 mm) Touchscreen LCD

The Touchscreen LCD shows the machine's status when the machine is idle.



- 1  **Fax**
Lets you access the Fax mode.
- 2  **Copy**
Lets you access the Copy mode.
- 3  **Scan**
Lets you access the Scan mode.



4 Wireless Status

A four-level indicator on the Ready mode screen shows the current wireless signal strength when using a wireless connection.





If you see  at the top of the screen, you can easily configure the wireless settings by pressing it. For more information, see Quick Setup Guide.

5 Web

Lets you connect the Brother machine to an Internet service when you press , and then press .

For more information, see Web Connect Guide.

6 Photo

Lets you access Photo mode when you press , and then press .

7 A3 Copy Shortcuts

You can quickly copy to A3 or Ledger size paper using this preset menu. For details, see Advanced User's Guide: *A3 Copy Shortcuts*.

8 Settings

Lets you access the main settings. For more information, see *Settings screen* on page 10.

9 Ink

Lets you see the available ink volume and also lets you access the *Ink* menu.

When the ink cartridge is near the end of its life or having a problem, an error icon is displayed on the ink colour. For more information, see Advanced User's Guide: *Checking the ink volume*.

10 Shortcuts

Lets you set up Shortcuts.

You can save certain settings as a Shortcut so you can quickly send a fax, make a copy, scan or use Web Connect services.

NOTE

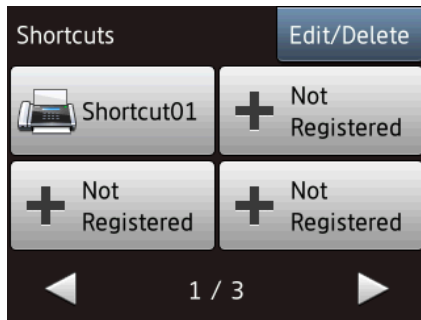

- Three Shortcut screens are available. You can set up to 4 Shortcuts on each Shortcut screen. A total of 12 Shortcuts are available.
- To display the other Shortcut screens, press ◀ or ▶.

11 Faxes in memory

You can see how many received faxes are in the memory ¹.

Press **Print** to print the faxes.

¹ When Fax Preview is set to *Off*.



12 New Fax(es)





When **Fax Preview** is set to *On*, you can see how many new faxes you have received and stored in the memory.

Press **View** to see your faxes on the Touchscreen.

13 Warning icon



The warning icon  appears when there is an error or maintenance message; press **Detail** to view it, and then press  to return to Ready mode.

For information about error messages, see *Error and maintenance messages* on page 104.

Settings screen

The Touchscreen LCD shows the machine status when you press  (Settings).

You can check and access all the machine's settings from the following screen.

(MFC-J6520DW)

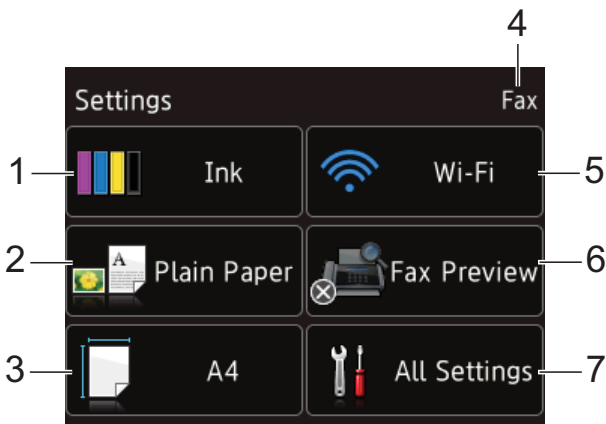

(MFC-J6720DW)

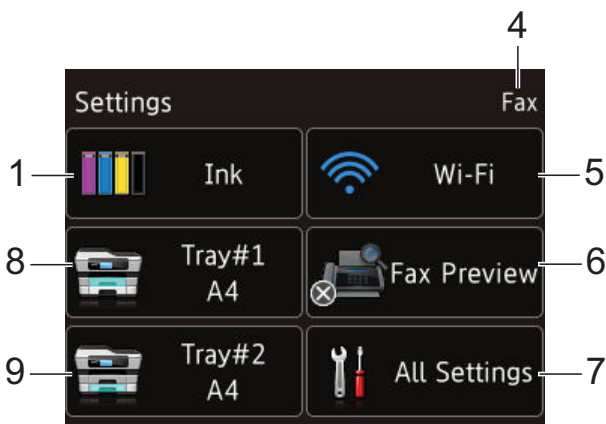

1 Ink

See the remaining ink volume.

When the ink cartridge is near the end of its life or having a problem, an error icon is displayed on the ink colour. For more information, see *Advanced User's Guide: Checking the ink volume*.

Press to access the Ink menu.

2 Paper Type (MFC-J6520DW)

See the selected paper type.

Press to change the Paper Type setting if needed.

3 Paper Size (MFC-J6520DW)

See the selected paper size.

Press to change the Paper Size setting if needed.

4 Receive Mode

See the current Receive Mode:

- Fax (Fax Only)
- Fax/Tel
- External TAD
- Manual

5 Wi-Fi

Press to set up a wireless network connection. A four-level indicator on the screen shows the current wireless signal strength if you are using a wireless connection.

6 Fax Preview

See the Fax Preview setting.

Press to access the Fax Preview setting.

7 All Settings

Press to access the full Settings menu.

8 Tray #1 (MFC-J6720DW)

Displays the size of paper in Tray #1. Also, lets you access the Tray #1 setting. You can change the paper size and paper type.

9 Tray #2 (MFC-J6720DW)

Displays the size of paper in Tray #2. Also, lets you access the Tray #2 setting. You can change the paper size.

Basic Operations

Press your finger on the Touchscreen LCD to operate it. To display and access all the screen menus and options, press ◀▶ or ▲▼ to scroll through them.

IMPORTANT

DO NOT touch the Touchscreen immediately after plugging in the power cord or turning on the machine. Doing this may cause an error.

The following steps show how to change a setting in the machine. In this example, the Receive Mode setting is changed from Fax Only to Fax/Tel.

- 1 Press  (Settings).
- 2 Press All Settings.
- 3 Press ▲ or ▼ to display Fax.

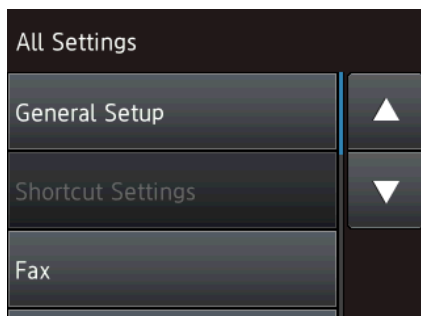

- 4 Press Fax.
- 5 Press ▲ or ▼ to display Setup Receive.

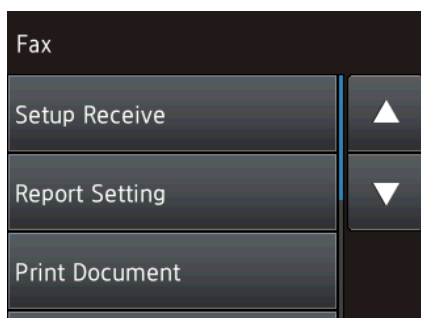

- 6 Press Setup Receive.
- 7 Press ▲ or ▼ to display Receive Mode.



- 8 Press Receive Mode.
- 9 Press ▲ or ▼ to display Fax/Tel.
- 10 Press Fax/Tel.

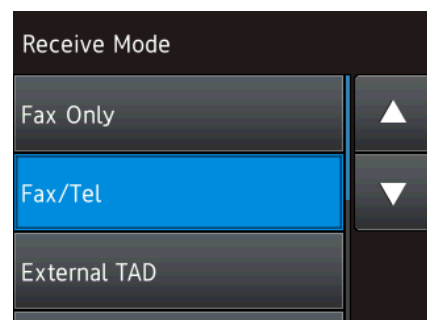



NOTE

Press  if you want to go back to the previous level.

- 11 Press .

Changing the keyboard setting

You can choose the type of keyboard for the Touchscreen.

- 1 Press  (Settings).
- 2 Press All Settings.
- 3 Press ▲ or ▼ to display General Setup.
- 4 Press General Setup.
- 5 Press ▲ or ▼ to display Keyboard Settings.
- 6 Press Keyboard Settings.
- 7 Press QWERTY or ABC.
- 8 Press .



Shortcut Settings

You can add the fax, copy, scan and Web Connect settings you use most frequently by setting them as your Shortcuts. Later you can quickly and easily recall and apply these settings. You can add up to 12 Shortcuts.

Adding Copy Shortcuts

The following settings can be included in a Copy Shortcut:

- ADF HighSpeed Mode
- Quality
- Paper Type
- Paper Size
- Tray Select (MFC-J6720DW)
- Enlarge/Reduce
- Density
- Stack/Sort
- Page Layout
- Auto Deskew
- 2-sided Copy
- Advanced Settings



- 1 Press  (Shortcuts).
- 2 Press  where you have not added a Shortcut.
- 3 Press ▲ or ▼ to display Copy.
- 4 Press Copy.
- 5 Read the information on the Touchscreen, and then confirm it by pressing OK.
- 6 Press ▲ or ▼ to display the available settings, and then press the setting you want to change.

- 7 Press ▲ or ▼ to display the available options for the setting, and then press the option you want to set. Repeat steps 6 and 7 until you have chosen all the settings for this Shortcut.
- 8 When you have finished changing settings, press *Save as Shortcut*.
- 9 Read and confirm the displayed list of settings you have chosen, and then press *OK*.
- 10 Enter a name for the Shortcut using the keyboard on the Touchscreen. (For help entering letters, see *Entering Text* on page 186.) Press *OK*.
- 11 Press *OK* to save your Shortcut.

Adding Fax Shortcuts

The following settings can be included in a fax Shortcut:

- Address
- Fax Resolution
- Contrast
- Glass Scan Size
- Broadcasting
- Preview
- Colour Setting
- Real Time TX
- Overseas Mode

- 1 Press  (Shortcuts).
- 2 Press  where you have not added a Shortcut.
- 3 Press ▲ or ▼ to display *Fax*.
- 4 Press *Fax*.

- 5 Read the information on the Touchscreen, and then confirm it by pressing *OK*.
- 6 Enter the fax number using the dial pad on the Touchpanel, or you can use the Address Book or Call History on the Touchscreen. When you have finished, go to step 7.

NOTE

- You can enter up to 20 digits for a fax number.
- If the Shortcut is to be used for broadcasting, press *Options* and choose *Broadcasting* in step 8 before entering the fax number in step 6.
- You can enter up to 20 fax numbers if the Shortcut is for broadcasting. The fax numbers can be entered in any combination of Group numbers from the Address Book and individual fax numbers from the Address Book or entered manually. (See *Advanced User's Guide: Broadcasting (Monochrome only)*.)
- When you enter a fax number in a Shortcut, it will be added to the Address Book. The name in the Address Book will be the Shortcut name plus a sequential number.

- 7 Press *Options*.
- 8 Press ▲ or ▼ to display the available settings, and then press the setting you want to change.
- 9 Press the new option you want to set. Repeat steps 8 and 9 until you have chosen all the settings for this Shortcut. Press *OK*.
- 10 When you have finished choosing new options, press *Save as Shortcut*.
- 11 Read and confirm the displayed list of options you have chosen, and then press *OK*.

- 12 Enter a name for the Shortcut using the keyboard on the Touchscreen. (For help entering letters, see *Entering Text* on page 186.)
Press **OK**.
- 13 Press **OK** to save your Shortcut.

Adding Scan Shortcuts

The following settings can be included in a scan Shortcut:

to Media

- ADF HighSpeed Mode
- Scan Type
- Resolution
- File Type
- Scan Size
- Scan Long Paper
- File Name
- Auto Crop
- Remove Background Colour

to E-mail Server (Available after IFAX has been downloaded)



- Address
- ADF HighSpeed Mode
- Scan Type
- Resolution
- File Type
- Scan Size
- Scan Long Paper

to File/to OCR/to Image/to E-mail

- PC Select

to FTP/to Network

- Profile Name

- 1 Press  (Shortcuts).
- 2 Press  where you have not added a Shortcut.
- 3 Press **▲** or **▼** to display Scan.
- 4 Press Scan.
- 5 Press **▲** or **▼** to display the type of scan you want to do, and then press it.
- 6 Do one of the following:
 - If you pressed to Media, read the information on the Touchscreen, and then press **OK** to confirm it. Go to step 9.
 - If you pressed to E-mail Server, read the information on the Touchscreen, and then press **OK** to confirm it. Go to step 7.
 - If you pressed to File, to OCR, to Image or to E-mail, read the information on the Touchscreen, and then press **OK** to confirm it. Go to step 8.
 - If you pressed to Network or to FTP, read the information on the Touchscreen, and then press **OK** to confirm it.

Press **▲** or **▼** to display the Profile Name, and then press it.

Press **OK** to confirm the Profile Name you have chosen. Go to step 14.

NOTE

To add a Shortcut for to Network and to FTP, you must have added the Profile Name beforehand.

- 7** Do one of the following:
- To enter an E-mail address manually, press **Manual**. Enter the E-mail address using the keyboard on the Touchscreen. (See *Entering Text* on page 186.)
Press **OK**.
 - To enter an E-mail address from the Address Book, press **Address Book**. Press **▲** or **▼** to display the E-mail address you want, and then press it.
Press **OK**.

After you confirm the E-mail address you entered, press **OK**. Go to step **9**.

NOTE

Press  to view the list of addresses you have entered.

- 8** Do one of the following:
- When the machine is connected to a PC using a USB connection:
Press **OK** to confirm **<USB>** is chosen as the PC Name. Go to step **14**.
 - When the machine is connected to a network:
Press **▲** or **▼** to display the PC Name, and then press it. Press **OK** to confirm the PC Name you have chosen. Go to step **14**.
- 9** Press **Options**.
- 10** Press **▲** or **▼** to display the available settings, and then press the setting you want to change or store.
- 11** Press **▲** or **▼** to display the available options for the setting, and then press the new option you want to set. Repeat steps **10** and **11** until you have chosen all the settings for this Shortcut. When you have finished changing settings, press **OK**.

- 12** Review the settings you have chosen:
- If you need to make more changes, return to step **9**.
 - If you are satisfied with your changes, press **Save as Shortcut**.
- 13** Review your settings on the Touchscreen, and then press **OK**.
- 14** Enter a name for the Shortcut using the keyboard on the Touchscreen. (For help entering letters, see *Entering Text* on page 186.)
Press **OK**.
- 15** Read the information on the Touchscreen, and then press **OK** to save your Shortcut.



Adding Web Connect Shortcuts

The settings for the following services can be included in a Web Connect Shortcut:

- SkyDrive®
- Box
- Google Drive™
- Evernote®
- Dropbox
- Facebook
- Picasa Web Albums™
- Flickr®

NOTE

- Web services may have been added and/or service names may have been changed by the provider since this document was published.
- To add a Web Connect Shortcut, you need to have an account with the desired service. (For more information, see *Web Connect Guide*.)

- 1 Press  (Shortcuts).
- 2 Press  where you have not added a Shortcut.
- 3 Press ▲ or ▼ to display Web.
- 4 Press Web.
- 5 If information about the Internet connection is displayed, read and confirm it by pressing OK.
- 6 Press ▲ or ▼ to display the available services, and then press the desired service.
- 7 Press your account.
If the account needs a PIN, enter the PIN for the account using the keyboard on the Touchscreen.
Press OK.
- 8 Choose the function you want to use.

NOTE

The available functions vary depending on the chosen service.

- 9 Read and confirm the displayed list of functions you have chosen, and then press OK.
- 10 Enter a name for the Shortcut using the keyboard on the Touchscreen. (For help entering letters, see *Entering Text* on page 186.)
Press OK.
- 11 Press OK to save your Shortcut.

Changing Shortcuts



You can change the settings in a Shortcut.

NOTE

You cannot edit existing Web Connect Shortcuts.

If you want to change a Web Connect Shortcut, you should delete it, and then add a new Shortcut.

(For more information, see *Deleting Shortcuts* on page 17 and *Adding Web Connect Shortcuts* on page 15.)

- 1 Press  (Shortcuts).
- 2 Press ◀ or ▶ to display the Shortcut you want to change.
- 3 Press the Shortcut you want to change.
The settings for the Shortcut that you chose are displayed.
- 4 Press Options.
- 5 Change the settings for the Shortcut you chose in step 3. (For example, see *Adding Copy Shortcuts* on page 12.)
- 6 Press Save as Shortcut when you have finished changing the settings.
- 7 Press OK to confirm.
- 8 Do one of the following:
 - If you want to overwrite the Shortcut, press Yes. Go to step 10.
 - If you do not want to overwrite the Shortcut, press No to enter a new Shortcut name. Go to step 9.
- 9 To edit the name, hold down  to delete the current name, and then enter a new name using the keyboard on the Touchscreen. (For help entering letters, see *Entering Text* on page 186.)
Press OK.

- 10 Press **OK** to confirm.



Editing Shortcut Names

You can edit a Shortcut name.

- 1 Press  (Shortcuts).
- 2 Press ◀ or ▶ to display the Shortcut you want to edit.
- 3 Press and hold the Shortcut until the options appear.

NOTE

You can also press **Edit/Delete**, and then press the Shortcut you want.

- 4 Press **Edit Shortcut Name**.
- 5 To edit the name, hold down  to delete the current name, and then enter a new name using the keyboard on the Touchscreen. (For help entering letters, see *Entering Text* on page 186.) Press **OK**.
- 6 Press .

Deleting Shortcuts

You can delete a Shortcut.

- 1 Press  (Shortcuts).
- 2 Press ◀ or ▶ to display the Shortcut you want to delete.
- 3 Press and hold the Shortcut until the options appear.

NOTE

You can also press **Edit/Delete**, and then press the Shortcut you want.

- 4 Press **Delete** to delete the Shortcut that you chose in step 3. Press **Yes** to confirm.
- 5 Press .

Recalling Shortcuts

The Shortcut settings are displayed on the Shortcut screen. To recall a Shortcut, simply press the Shortcut name.



- 1 Press  (Shortcuts).
- 2 Press ◀ or ▶ to display the Shortcut you want to recall.
- 3 Press the Shortcut.

Volume Settings

Ring Volume

You can choose from a range of ring volume levels. The machine will keep your new setting until you change it.



Setting the Ring Volume

- 1 Press  (Settings).
- 2 Press All Settings.
- 3 Press ▲ or ▼ to display General Setup.
- 4 Press General Setup.
- 5 Press ▲ or ▼ to display Volume.
- 6 Press Volume.
- 7 Press Ring.
- 8 Press Low, Med, High or Off.
- 9 Press .

Beeper Volume



When the beeper is on, the machine will make a sound when you press the Touchscreen or Touchpanel, or if you make a mistake, or after you send or receive a fax.

You can choose from a range of sound volume levels.

- 1 Press  (Settings).
- 2 Press All Settings.
- 3 Press ▲ or ▼ to display General Setup.
- 4 Press General Setup.
- 5 Press ▲ or ▼ to display Volume.
- 6 Press Volume.
- 7 Press Beep.
- 8 Press Low, Med, High or Off.
- 9 Press .

Speaker Volume



You can choose from a range of speaker volume levels.

- 1 Press  (Settings).
- 2 Press All Settings.
- 3 Press ▲ or ▼ to display General Setup.
- 4 Press General Setup.
- 5 Press ▲ or ▼ to display Volume.
- 6 Press Volume.
- 7 Press Speaker.
- 8 Press Low, Med, High or Off.
- 9 Press .

Touchscreen LCD

Setting the Backlight brightness

If you are having difficulty reading the Touchscreen LCD, try changing the brightness setting.

- 1 Press  (Settings).
- 2 Press All Settings.
- 3 Press ▲ or ▼ to display General Setup.
- 4 Press General Setup.
- 5 Press ▲ or ▼ to display LCD Settings.
- 6 Press LCD Settings.
- 7 Press Backlight.
- 8 Press Light, Med or Dark.
- 9 Press .

2

Loading paper

Loading paper and other print media

⚠ CAUTION

DO NOT carry the machine by holding the scanner cover, the Jam Clear Cover, the manual feed slot cover, or the control panel. Doing this may cause the machine to slip out of your hands. Carry the machine by sliding your hands into the handhold indentations located on each side of the machine.

For detailed information, see Product Safety Guide.

NOTE

(MFC-J6720DW)

For tray #2 (lower tray), see *Loading paper in paper tray #2 (MFC-J6720DW)* on page 28.

Loading paper in paper tray #1

Load only one size of paper and one type of paper in the paper tray at a time.

(For more information about paper size, weight and thickness, see *Choosing the right print media* on page 41.)

You must load paper sizes A4 or Letter in *Landscape* position. Load A3, Ledger, Legal, Folio or smaller paper (A5/A6/Photo/Photo L/Photo 2L/Index cards/envelopes) in *Portrait* position.

NOTE

When you load a different paper size in the tray, you must change the machine's Paper Size setting at the same time.

(MFC-J6520DW: See *Paper Size (MFC-J6520DW)* on page 37.)

(MFC-J6720DW: See *Paper Size and Type (MFC-J6720DW)* on page 37.)

- 1 Pull the paper tray completely out of the machine.

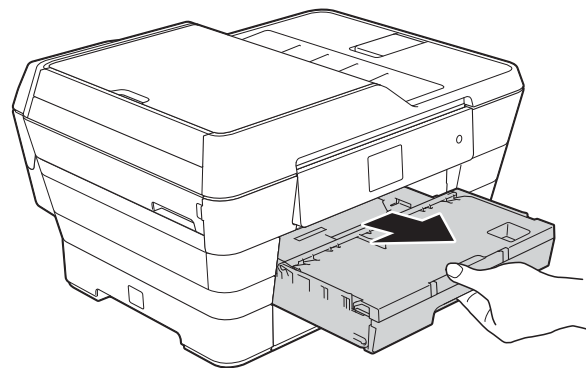

NOTE

If the paper support flap (1) is open, close it, and then close the paper support (2).

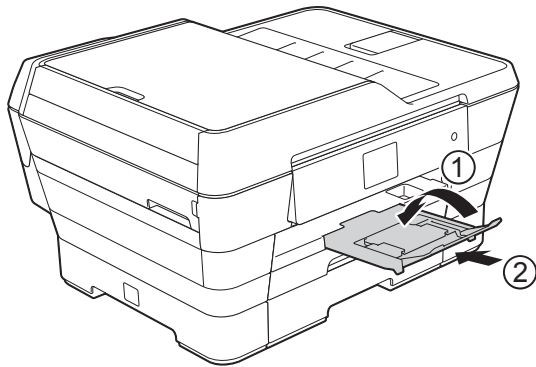

2 Adjust the tray length if needed:

■ **When using A3, Ledger, Legal, or Folio size paper**

Press the universal guide release button (1) as you slide out the front of the paper tray.

Make sure that the triangular mark on the output paper tray cover is aligned with the line indicating Legal or Folio (2) or A3 or Ledger (3) size, as shown in the illustration.

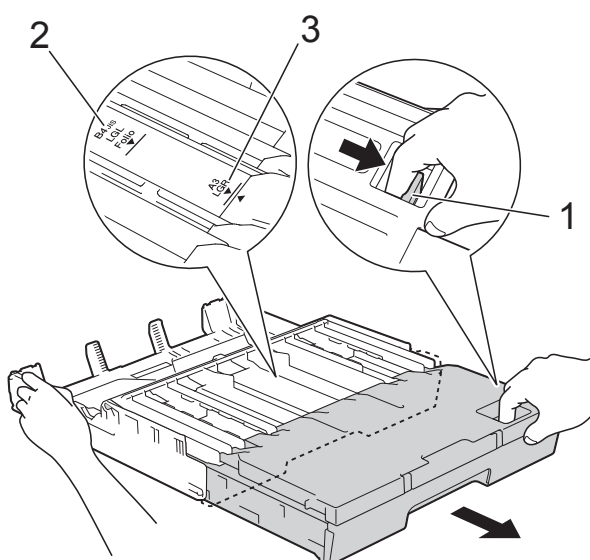

■ **When using A4, Letter, or smaller size paper**

If you are using A4 or Letter, you do not have to extend the tray. If tray #2 is extended, then extend tray #1 and pull up the stopper.

If you are using A5 or smaller size paper, make sure the paper tray is not extended.

- 3** Gently press and slide the paper side guides (1) to fit the paper size. Make sure that the triangular mark (2) on the paper side guide (1) lines up with the mark for the paper size you are using.

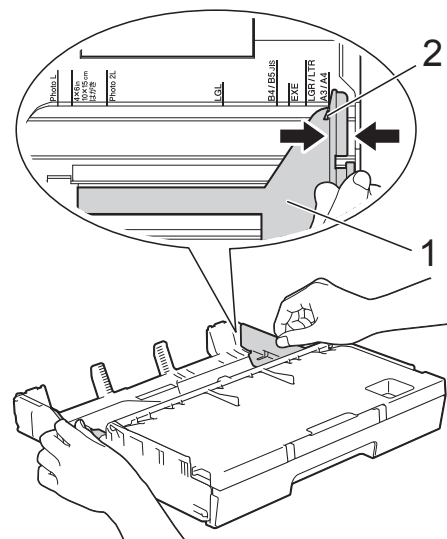

- 4** Open the output paper tray cover (1).

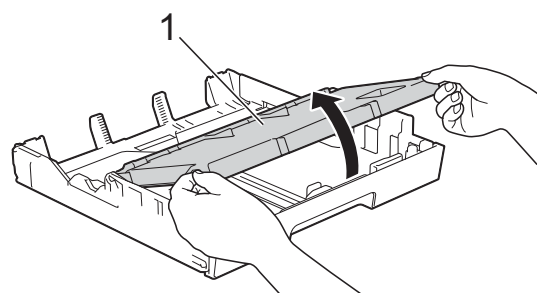

- 5 Gently press and slide the paper length guide (1) to fit the paper size. Make sure that the triangular mark (2) on the paper length guide (1) lines up with the mark for the paper size you are using.

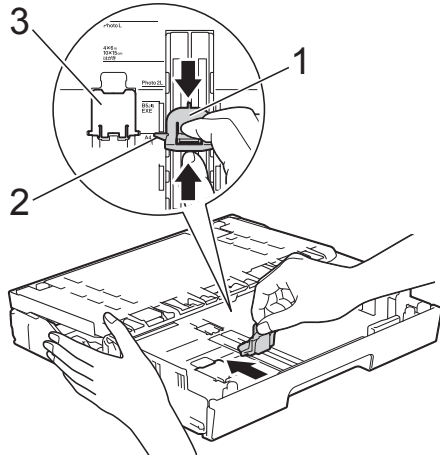

NOTE

(MFC-J6720DW)
If you are loading A4 or Letter size paper in tray #1 and must extend it because tray #2 is extended, lift up the A4/LTR stopper (3) to hold the paper in landscape position.

(For instructions about how to extend tray #1 over tray #2, see *Loading paper in paper tray #2 (MFC-J6720DW)* on page 28.)

- 6 Fan the stack of paper well to avoid paper jams and misfeeds.

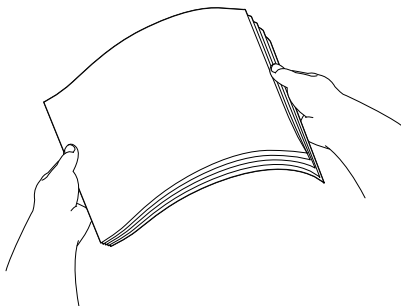

NOTE

Always make sure that the paper is not curled.

- 7 To load paper in the tray, do one of the following:

■ **When using A4 or Letter size paper**

- 1 Close the output paper tray cover.

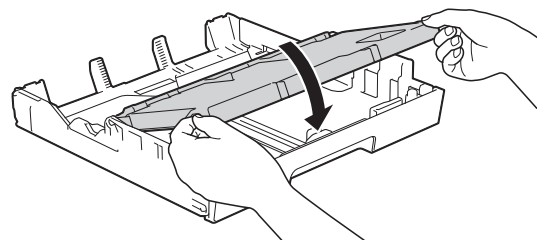

- 2 Gently put the paper into the paper tray print side down. Check that the paper is flat in the tray.

Landscape orientation

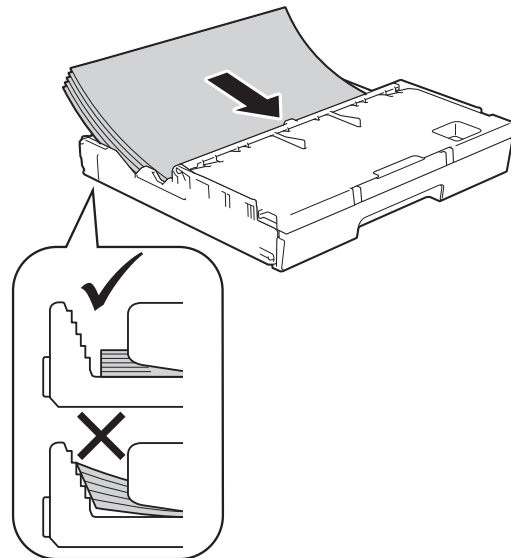

■ **When using A3, Ledger, Legal or Folio size paper**

- 1 Gently put the paper into the paper tray print side down and top edge first. Check that the paper is flat in the tray.

Portrait orientation

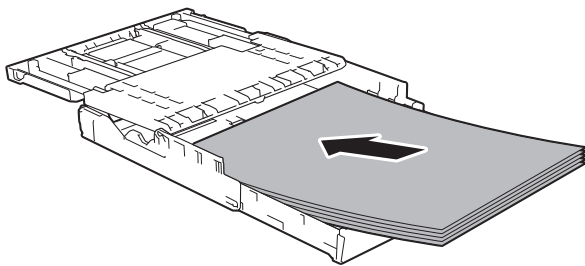

- 2 Close the output paper tray cover.

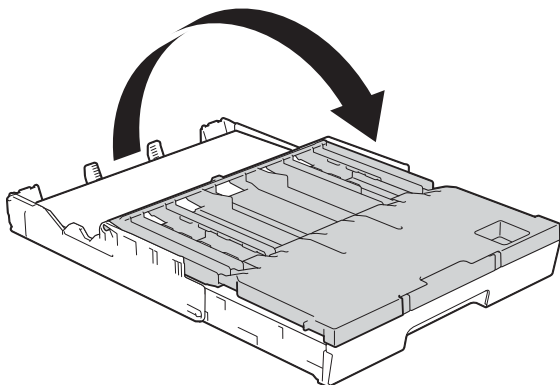

- 8 Gently adjust the paper side guides to fit the paper using both hands. Make sure the paper side guides touch the sides of the paper.

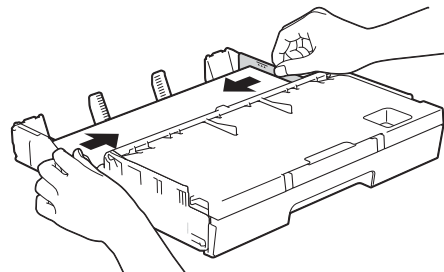

NOTE

Be careful not to push the paper in too far; it may lift at the back of the tray and cause feed problems.

- 9 Check that the paper is flat in the tray and below the maximum paper mark (1). Overfilling the paper tray may cause paper jams.

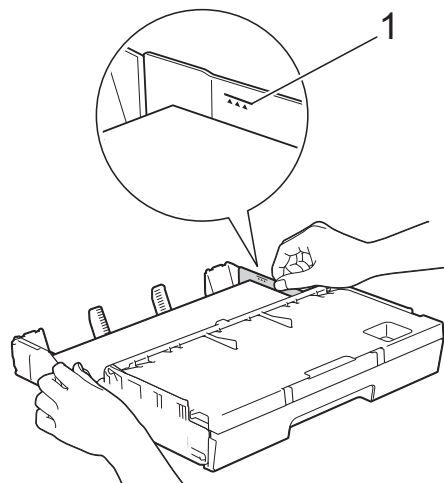

- 10 Slowly push the paper tray completely into the machine.

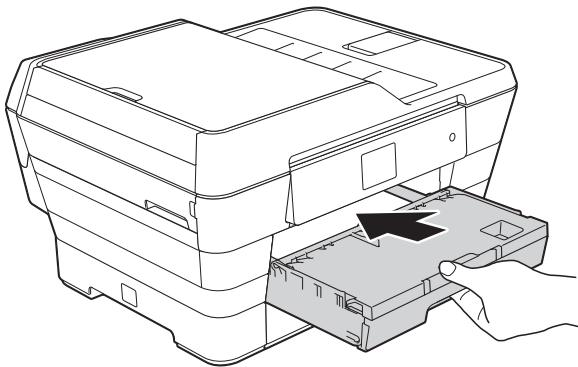

⚠ CAUTION

DO NOT push Tray #1 into the machine too quickly. Doing this may cause injury to your hand by trapping it between Tray #1 and Tray #2. Please push Tray #1 *slowly*.

- 11 While holding the paper tray in place, pull out the paper support (1) until it locks into place, and then unfold the paper support flap (2).

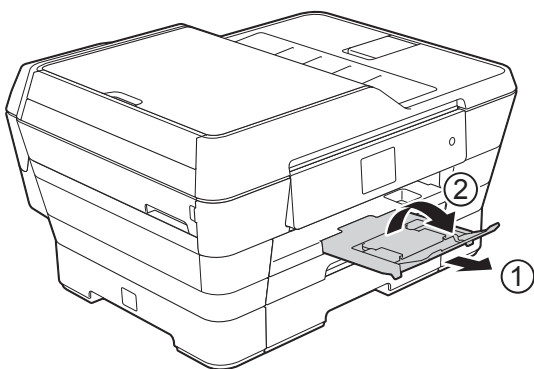

NOTE

Before you shorten Tray #1, take the paper out of the tray. Then shorten the tray by pressing the universal guide release button (1). Adjust the paper length guide (2) to fit the paper size you are going to use. Then put the paper in the tray.

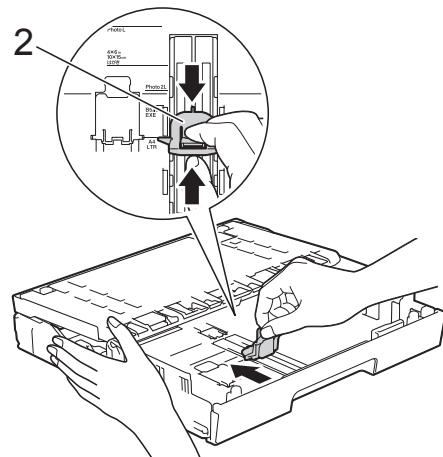
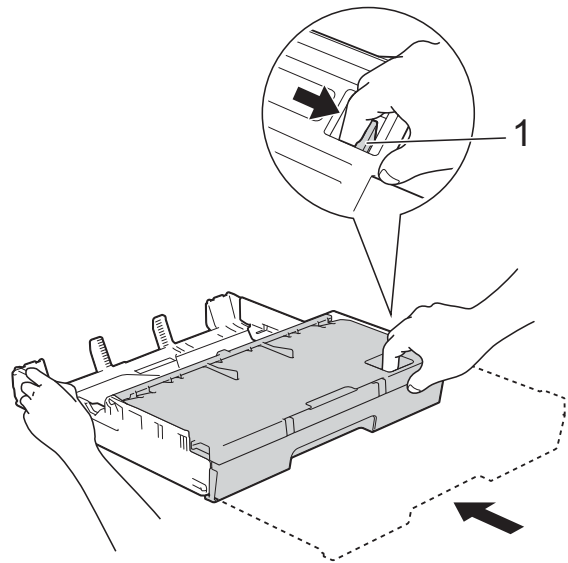

Loading smaller paper (Photo, Photo L, Photo 2L or envelopes)

Portrait orientation

(A5 or smaller size paper)

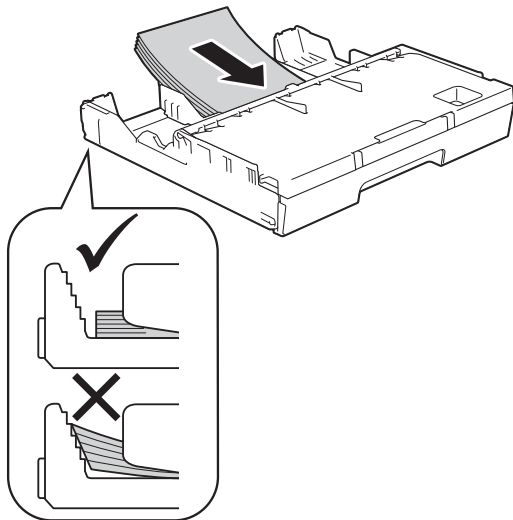

IMPORTANT

Be careful not to push the paper in too far; it may lift at the back of the tray and cause paper feed problems.

Loading Photo, Photo L and Photo 2L paper

- 1 Before loading, press the corners and sides of the Photo, Photo L and Photo 2L paper to make them as flat as possible.

IMPORTANT

If Photo (10 × 15 cm), Photo L (89 × 127 mm) or Photo 2L (13 × 18 cm) paper is “double-feeding,” put only one sheet of Photo or Photo L paper in the paper tray at a time.

- 2 Do one of the following:
 - If you load Photo L (89 × 127 mm) in the paper tray, lift up the Photo L stopper (1).

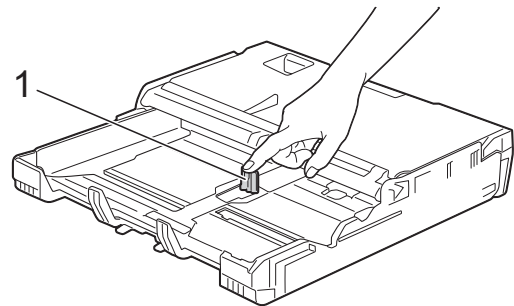

- If you load Photo (10 × 15 cm) or Photo 2L (13 × 18 cm) in the paper tray, open the output paper tray cover.

Gently press the paper length guide (1) to fit the paper size, and then close the output paper tray cover.

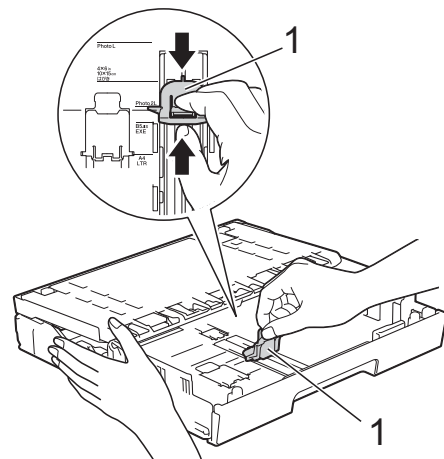

- 3 Gently press the paper side guides to fit the paper size.

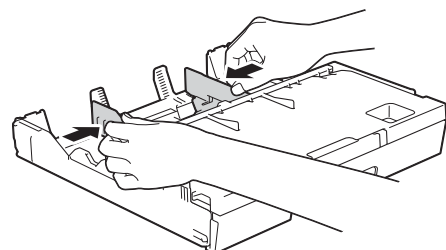

- 4 Put Photo, Photo L, or Photo 2L paper in the paper tray print side down.

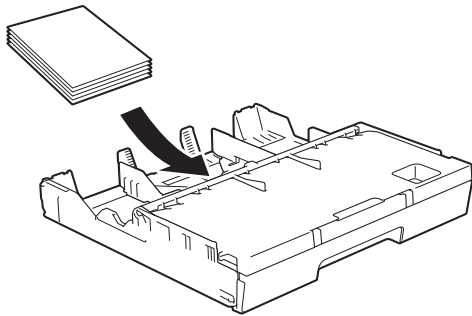

- 5 Gently adjust the paper side guides to fit the paper. Make sure the paper side guides touch the sides of the paper.

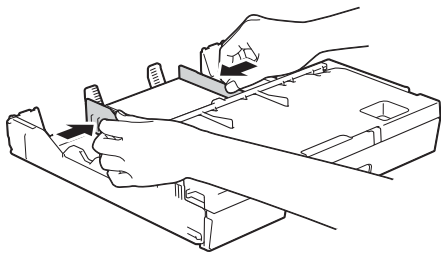

About envelopes

- Use envelopes that weigh between 80 to 95 g/m².
- Some envelopes need margin settings to be set in the application. Make sure you do a test print first before printing multiple envelopes.

IMPORTANT

DO NOT use the following types of envelopes, as they will not feed correctly:

- That are of a baggy construction.
- That have windows.
- That are embossed (have raised writing on them).
- That have clasps or staples.
- That are pre-printed on the inside.

Glue	Double flaps

Occasionally you may experience paper feed problems caused by the thickness, size and flap shape of the envelopes you are using.

Loading envelopes

- 1 Before loading, press the corners and sides of the envelopes to make them as flat as possible.

IMPORTANT

If envelopes are “double-feeding”, put one envelope in the paper tray at a time.

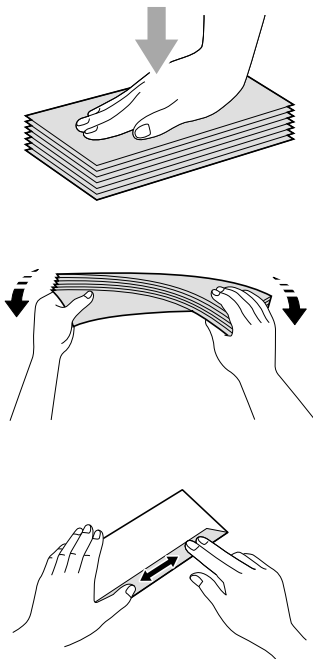

- 2 Gently press and slide the paper side guides to fit the paper size.

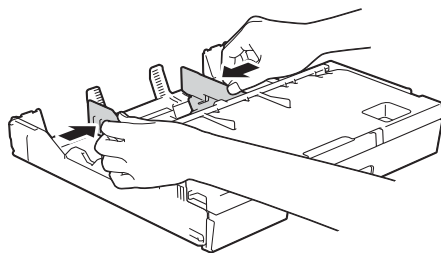

- 3 Put envelopes in paper tray #1 with the address side down. If the envelope flaps are on the long edge, load the envelopes with the flap on the left, as shown in the illustration. Gently adjust the paper side guides (1) to fit the size of the envelopes.

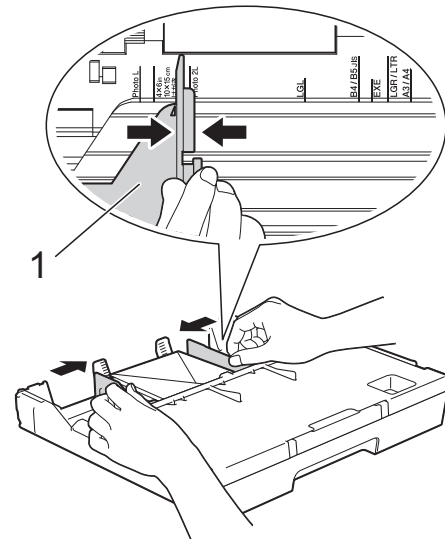

If you have problems printing on envelopes with the flap on the short edge, try the following:

- 1 Open the envelope flap.
- 2 Put the envelope into paper tray #1 with the address side down and the flap positioned as shown in the illustration.

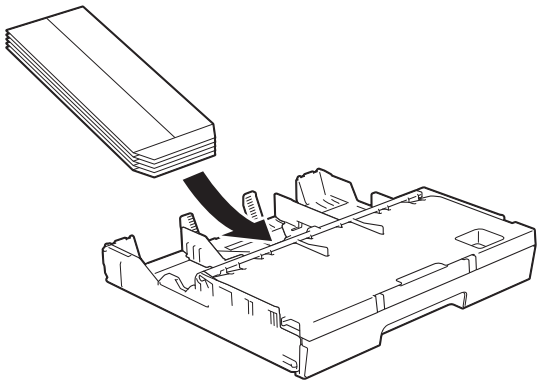

- 3 Select **Reverse Print** (Windows®) or **Reverse page orientation** (Macintosh) in the printer driver's dialog box, and then adjust the size and margin in your application. (See Software and Network User's Guide.)

Loading paper in paper tray #2 (MFC-J6720DW)

NOTE

You can only use plain paper sizes A4 or Letter (in Landscape position) and A3, Legal or Ledger (in Portrait position) in tray #2.

- 1 Pull the paper tray completely out of the machine.

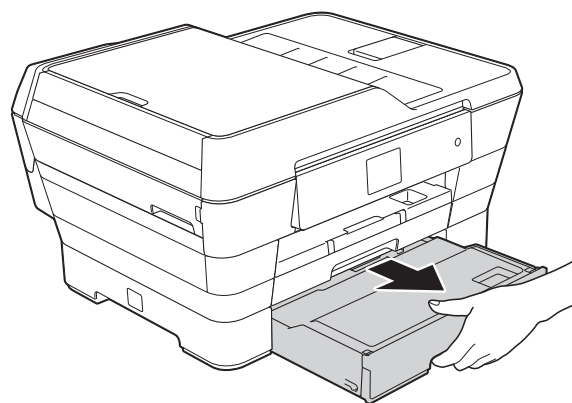

2 Adjust the tray length, if needed:

■ **When using A3, Ledger, or Legal size paper**

Press the universal guide release button (1) as you slide out the front of the paper tray.

You can check if the length of the tray is adjusted correctly by opening the paper tray cover.

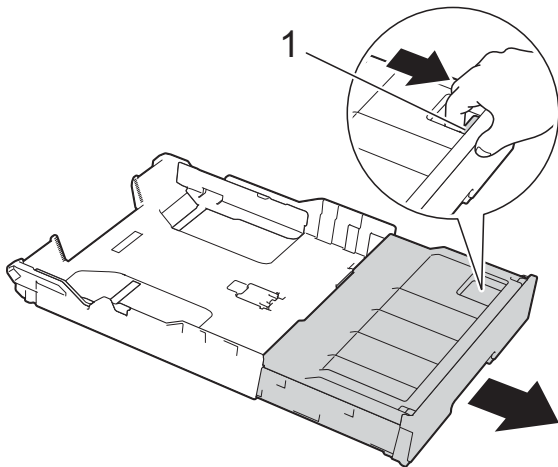

■ **When using A4 or Letter**

If you are using A4 or Letter, you do not have to extend the tray.

3 Open the paper tray cover (1).

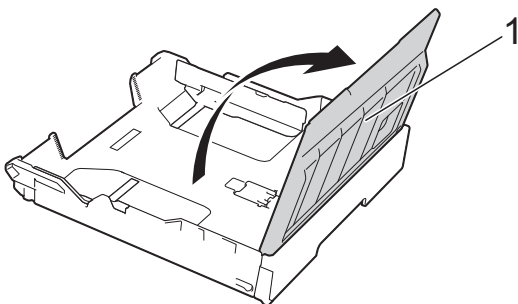

4 Gently press and slide the paper side guides (1) to fit the paper size. If you are loading A4 or Letter size paper, put it in landscape position and lift up the A4/LTR stopper (2).

Make sure that the triangular mark (3) on the paper side guide lines up with the marks for the paper size you are using.

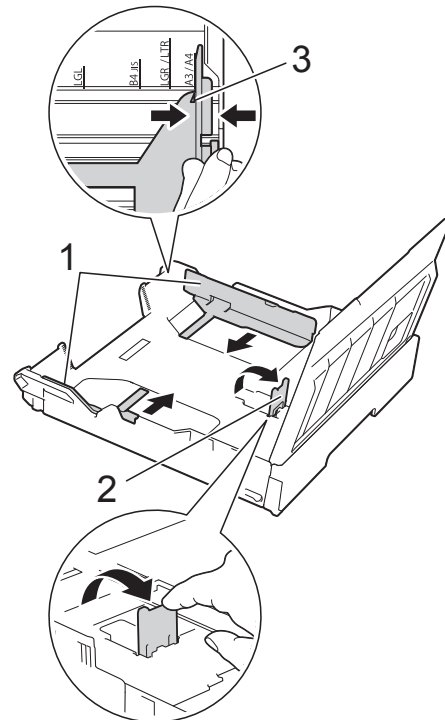

5 Fan the stack of paper well to avoid paper jams and misfeeds.

NOTE

Always make sure that the paper is not curled.

- 6 Gently put the paper into the paper tray print side down.

■ **When using A4 or Letter size paper**

Landscape orientation

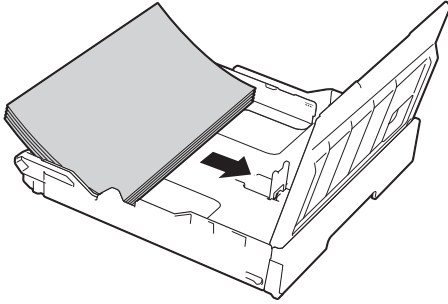

■ **When using A3, Ledger, or Legal size paper**

Portrait orientation

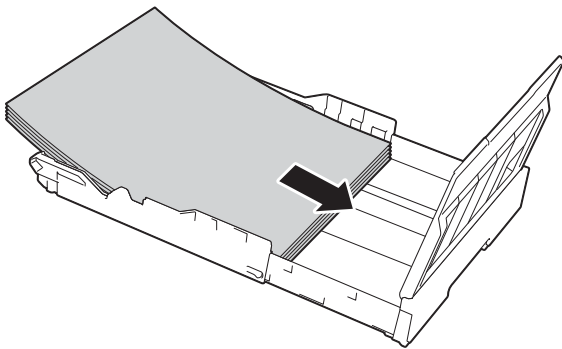

- 7 Gently adjust the paper side guides so they touch the sides of the paper stack.

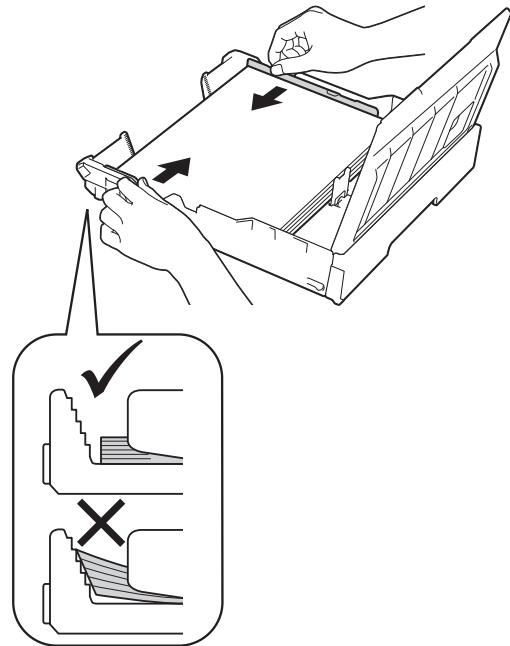

NOTE

Be careful not to push the paper in too far; it may lift at the back of the tray and cause feed problems.

- 8 Check that the paper is flat in the tray and below the maximum paper mark (1). Overfilling the paper tray may cause paper jams.

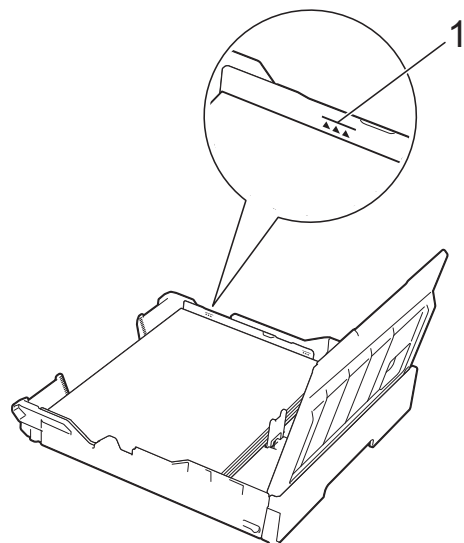

- 9 Close the paper tray cover.

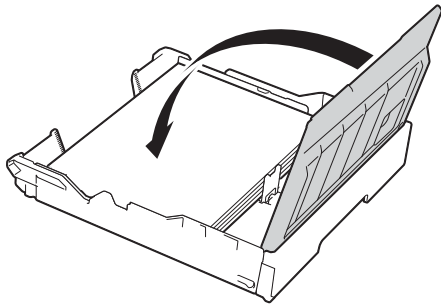

- 10 Slowly push the paper tray back into the machine.

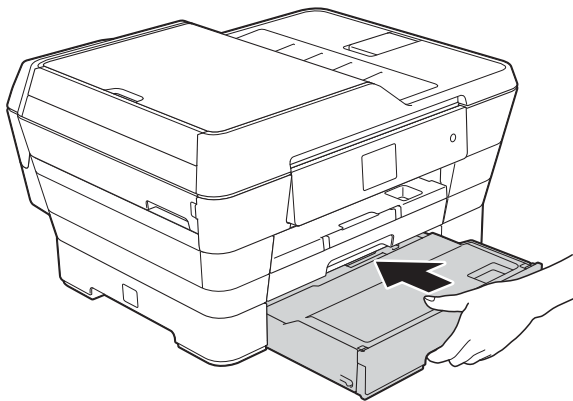

- 11 Do one of the following:
- If you are using A3, Ledger or Legal size paper, go to step 12.

NOTE

When Tray #2 is extended for large size paper, you must also extend Tray #1 out over Tray #2 to prevent printed pages from falling off the output tray.

- If you are using A4 or Letter size paper, pull out the paper support (1) until it locks into place, and then unfold the paper support flap (2).

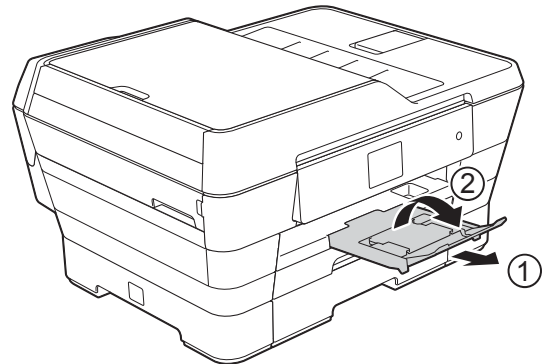

- 12 **Extending tray #1 over tray #2**
Pull tray #1 out of the machine. Press the universal guide release button (1) as you slide out the front of the paper tray.

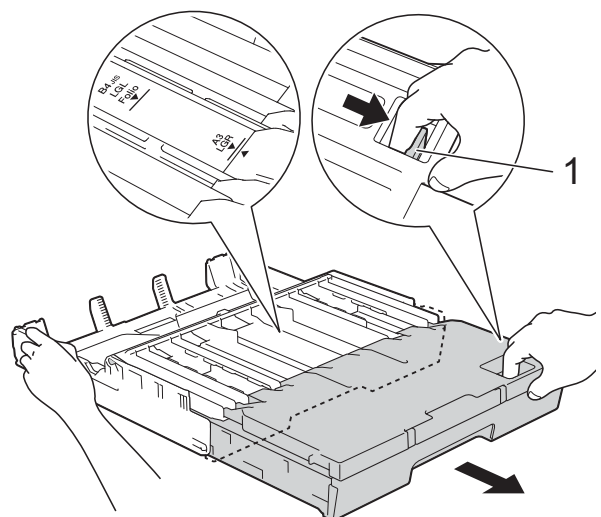
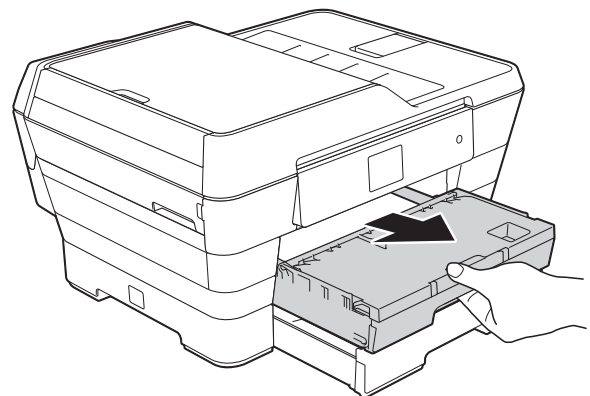

- 13 Open the output paper tray cover and lift the A4/LTR stopper (1).

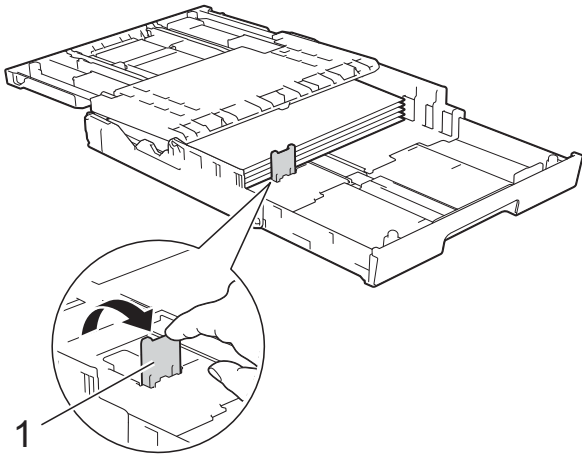

- 14 Close the output paper tray cover and *slowly* push the paper tray into the machine.

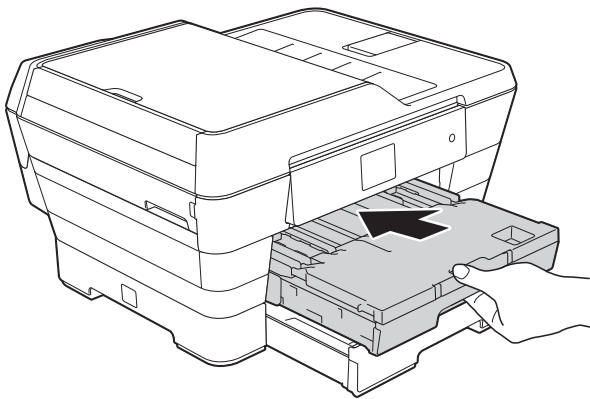

- 15 Pull out the paper support (1) until it locks into place, and then unfold the paper support flap (2).

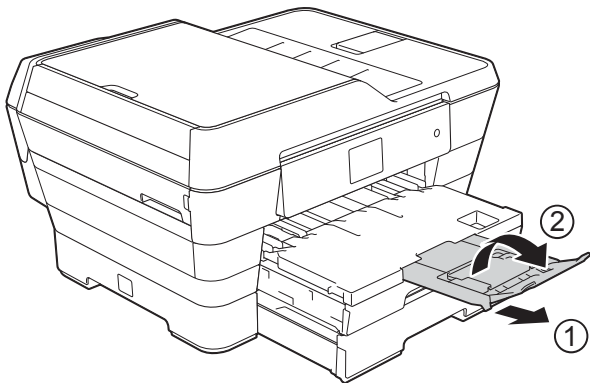

NOTE

If you are finished using A3, Ledger or Legal size paper and want to use A4 or Letter size paper, take the paper out of the tray.

Shorten the tray by pressing the universal guide release button (1). Adjust the paper side guides (2) to fit A4 or Letter size paper. Lift up the A4/LTR stopper (3). Then put the paper into the tray.

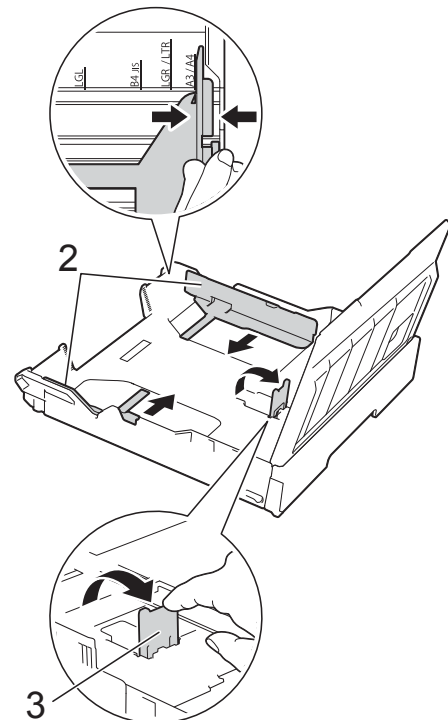
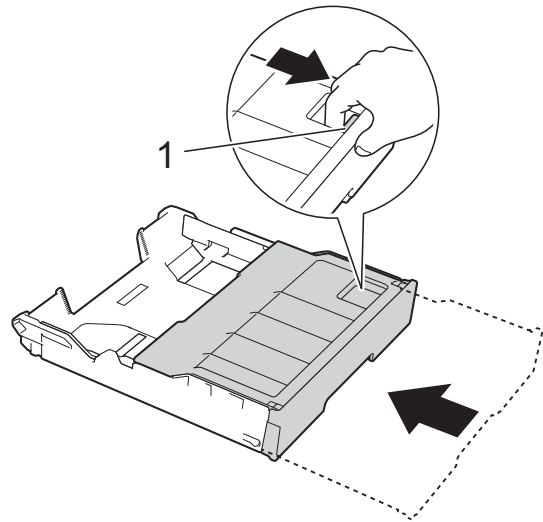

Loading paper in the manual feed slot

You can load special print media into this slot one sheet at a time.

Use the manual feed slot to print or copy on A3, Ledger, Legal, Folio, A4, Letter, Executive, A5, A6, envelopes, Photo (10 × 15 cm), Photo L (89 × 127 mm), Photo 2L (13 × 18 cm) and Index Card (127 × 203 mm.).

NOTE

The machine automatically turns on Manual Feed mode when you load paper in the manual feed slot.

- 1 Open the manual feed slot cover.

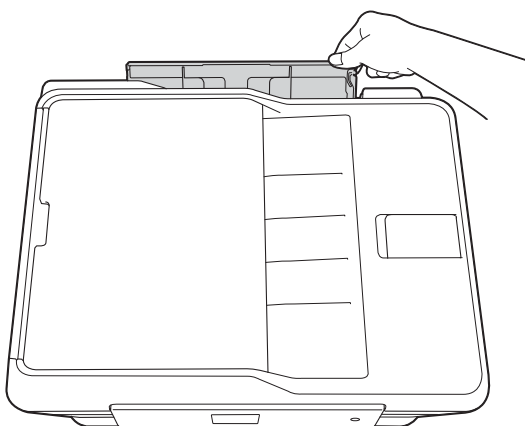
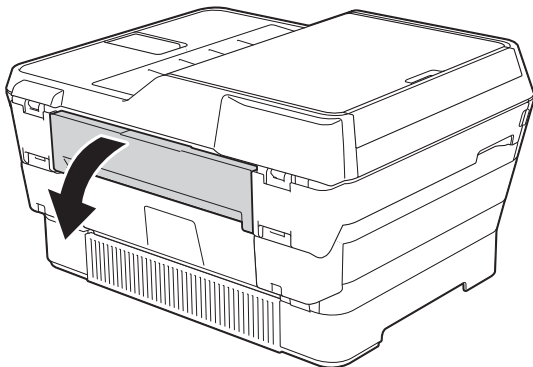

- 2 Slide the manual feed slot paper guides to fit the paper width that you are going to use.

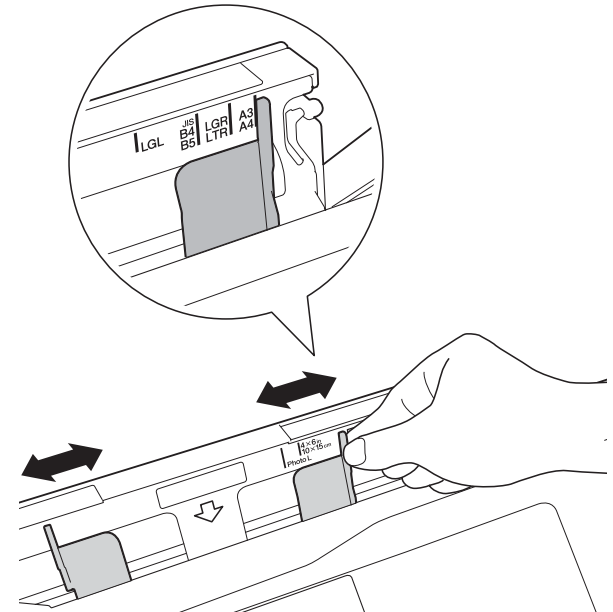

NOTE

For information about the paper orientation, follow the label attached on the right side of the manual feed slot.



When you slide the paper guides, confirm that they are in these positions.

- 3 Load *only one* sheet of paper in the manual feed slot with the side to be printed on *face up*.

- **When using A3, Ledger, Legal, Folio, A5, A6, envelopes, Photo, Photo L, Photo 2L or Index Card**
Portrait orientation

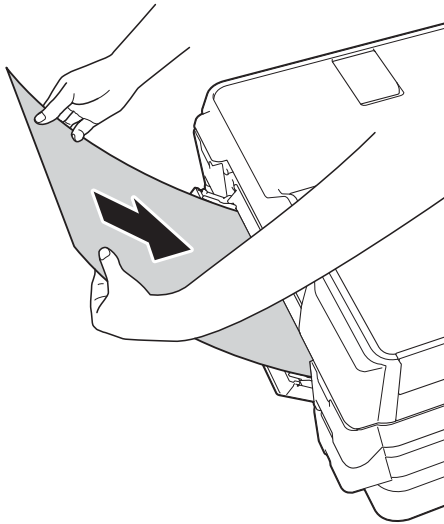

- **When using A4, Letter or Executive**
Landscape orientation

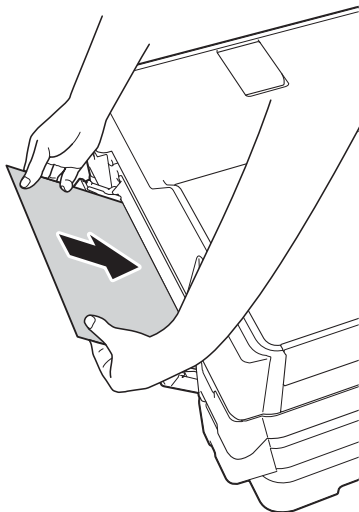

IMPORTANT

- DO NOT put more than one sheet of paper in the manual feed slot at any one time. Doing this may cause a paper jam. Even if you are printing multiple pages, do not feed the next sheet of paper until the Touchscreen shows a message instructing you to feed the next sheet.



- DO NOT put paper in the manual feed slot when you are printing from the paper tray. Doing this may cause a paper jam.
- For details about the paper orientation, see *Paper orientation and capacity of the paper trays* on page 42.

- 4 Using both hands, gently adjust the manual feed slot paper guides to fit the paper.

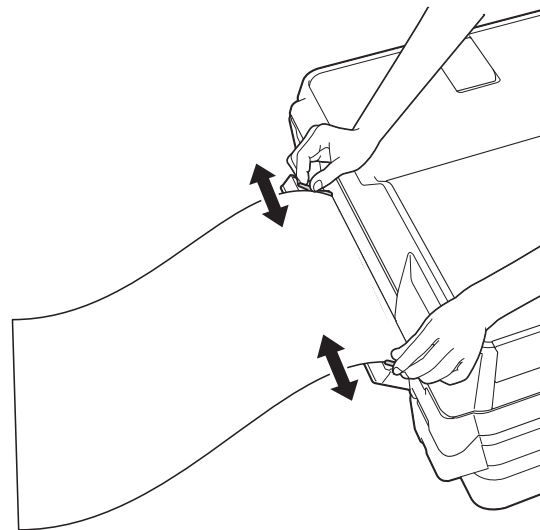

NOTE

- DO NOT press the paper guides too tightly against the paper. Doing this may cause the paper to fold.
- Place the paper in the centre of the manual feed slot between the paper guides. If the paper is not centred, pull it out and insert it again at the centre position.

- 5 Using both hands, put one sheet of paper in the manual feed slot until the front edge touches the paper feed roller. Let go of the paper when you hear the machine pull it in a short distance. The Touchscreen will show
Manual Feed Slot ready.

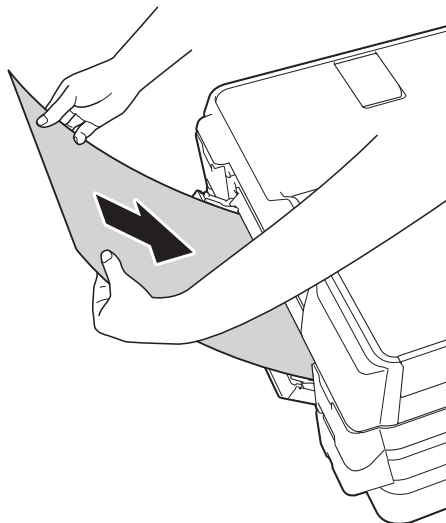
**NOTE**

When loading an envelope or a sheet of thick paper, push the envelope into the manual feed slot until you feel it grab the envelope.

- 6 If the data does not fit on one sheet, the Touchscreen will prompt you to load another sheet of paper. Place another sheet of paper in the manual feed slot, and then press **OK** on the Touchscreen.

NOTE

- Make sure printing has finished before you close the manual feed slot cover.
- When paper is placed in the manual feed slot, the machine always prints from the manual feed slot.
- Paper inserted in the manual feed slot while a test page, fax or report is being printed will be ejected.
- During the machine's cleaning process, paper you place in the manual feed slot will be ejected. Wait until the machine finishes its cleaning, and then put the paper into the manual feed slot again.

Unprintable area

The printable area depends on the settings in the application you are using. The figures show the unprintable areas on cut-sheet paper and envelopes.

Cut-Sheet Paper

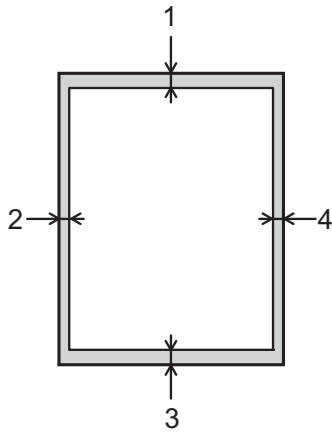

Envelopes

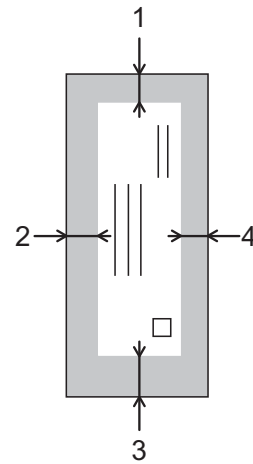

	Top (1)	Left (2)	Bottom (3)	Right (4)
Cut-Sheet	3 mm	3 mm	3 mm	3 mm
Envelopes	22 mm	3 mm	22 mm	3 mm



NOTE

- The machine can print in the shaded areas of cut-sheet paper when the Borderless print feature is available and turned on. (See Software and Network User's Guide.)
- The Borderless print feature is not available for envelopes and 2-sided printing.

Paper settings

Paper Type (MFC-J6520DW)

To get the best print quality, set the machine for the type of paper you are using.



- 1 Press  (Settings).
- 2 Press .
- 3 Press **▲** or **▼** to display Plain Paper, Inkjet Paper, Brother BP71, Other Glossy or Transparency, and then press the option you want to set.
- 4 Press .

NOTE

The machine ejects paper onto the paper tray on the front of the machine with the printed side face up. When you use transparencies or glossy paper, remove each sheet at once to prevent smudging or paper jams.

Paper Size (MFC-J6520DW)

You can use the following sizes of paper for printing copies: A4, A5, A3, 10 × 15 cm, Letter, Legal and Ledger. You can use the following sizes for printing faxes: A4, A3, Ledger, Letter and Legal. When you change the size of paper you load in the machine, you will need to change the paper size setting at the same time so your machine can fit an incoming fax on the page.

- 1 Press  (Settings).
- 2 Press .
- 3 Press **▲** or **▼** to display A4, A5, A3, 10x15cm, Letter, Legal or Ledger and then press the option you want to set.
- 4 Press .

Paper Size and Type (MFC-J6720DW)

To get the best print quality, set the machine for the type of paper you are using.

You can use the following sizes of paper for printing copies: A4, A5, A3, 10 × 15 cm, Letter, Legal and Ledger and five sizes for printing faxes: A4, A3, Ledger, Letter and Legal. When you load a different size of paper in the machine, you will need to change the paper size setting at the same time so your machine can fit an incoming fax on the page.

- 1 Press  (Settings).
- 2 Press the displayed paper size for Tray #1 or Tray #2.

- 3 Do one of the following:
- If you press the displayed paper size for Tray #1, press `Paper Type`.
Press **▲** or **▼** to display `Plain Paper`, `Inkjet Paper`, `Brother BP71`, `Other Glossy` or `Transparency`, and press the option you want.
Press `Paper Size`.
Press **▲** or **▼** to display `A4`, `A5`, `A3`, `10x15cm`, `Letter`, `Legal` or `Ledger`, and press the option you want.
 - If you press the displayed paper size for Tray #2, press `Paper Size`.
Press **▲** or **▼** to display `A4`, `A3`, `Letter`, `Legal` or `Ledger`, and press the option you want.

- 4 Press .

NOTE



- You can use only plain paper in Tray #2.
- The machine ejects paper onto the paper tray on the front of the machine with the printed side face up. When you use transparencies or glossy paper, remove each sheet at once to prevent smudging or paper jams.

Tray use in Copy mode (MFC-J6720DW)

You can change the default tray the machine will use for copies.

Auto Tray Select will allow your machine to feed paper from either Tray #1 or Tray #2, using the paper type and size settings from the Copy menu.

To change the default setting follow the instructions below:

- 1 Press  (Settings).
- 2 Press `All Settings`.
- 3 Press **▲** or **▼** to display `General Setup`.
- 4 Press `General Setup`.
- 5 Press **▲** or **▼** to display `Tray Setting`.
- 6 Press `Tray Setting`.
- 7 Press `Tray Use: Copy`.
- 8 Press `Tray #1`, `Tray #2` or `Auto Tray Select`.
- 9 Press .

NOTE



You can change the paper size and tray selection temporarily for the next copy. (See *Paper Size* on page 77 and *Tray Select (MFC-J6720DW)* on page 78.)

Tray use in Fax mode (MFC-J6720DW)

You can change the default tray the machine will use for printing received faxes.

Auto Tray Select will allow your machine to take paper from Tray #1 first, or from Tray #2 if:

- Tray #2 is set to a different paper size that is more suitable for the received faxes.
- Both trays are using the same size paper and Tray #1 is not set to use plain paper.

- 1 Press  (Settings).
- 2 Press All Settings.
- 3 Press ▲ or ▼ to display General Setup.
- 4 Press General Setup.
- 5 Press ▲ or ▼ to display Tray Setting.
- 6 Press Tray Setting.
- 7 Press Tray Use: Fax.
- 8 Press Tray #1, Tray #2 or Auto Tray Select.
- 9 Press .

Acceptable paper and other print media

The print quality can be affected by the type of paper you use in the machine.

To get the best print quality for the settings you have chosen, always set the Paper Type to match the type of paper that is loaded in the tray.

You can use plain paper, inkjet paper (coated paper), glossy paper, transparencies and envelopes.

We recommend testing various paper types before buying large quantities.

For best results, use Brother paper.

- When you print on inkjet paper (coated paper), transparencies and glossy paper, be sure to choose the correct print media in the **Basic** tab of the printer driver or in the Paper Type setting of the machine's menu.

(MFC-J6520DW: See *Paper Size (MFC-J6520DW)* on page 37.)

(MFC-J6720DW: See *Paper Size and Type (MFC-J6720DW)* on page 37.)

- When you print on Brother Photo paper, load one extra sheet of the same photo paper in the paper tray. An extra sheet has been included in the paper package for this purpose.
- When using transparencies or photo paper, remove each sheet at once to prevent smudging or paper jams.
- Avoid touching the printed surface of the paper immediately after printing; the surface may not be completely dry and may stain your fingers.

Recommended print media

To get the best print quality, we suggest using the Brother paper in the table.

If Brother paper is not available in your country, we recommend testing various papers before purchasing large quantities.

We recommend using 3M Transparency Film when you print on transparencies.

Brother paper

Paper Type	Item
A3 Plain	BP60PA3
A3 Glossy Photo	BP71GA3
A3 Inkjet (Matte)	BP60MA3
A4 Plain	BP60PA
A4 Glossy Photo	BP71GA4
A4 Inkjet (Matte)	BP60MA
10 × 15 cm Glossy Photo	BP71GP

Handling and using print media

- Store paper in its original packaging and keep it sealed. Keep the paper flat and away from moisture, direct sunlight and heat.
- Avoid touching the shiny (coated) side of the photo paper.
- Avoid touching either side of the transparency paper because they absorb water and perspiration easily, and this may cause decreased output quality. Transparencies designed for laser printers/copiers may stain your next document. Use only transparencies recommended for inkjet printing.

IMPORTANT

DO NOT use the following kinds of paper:

- Damaged, curled, wrinkled, or irregularly shaped paper

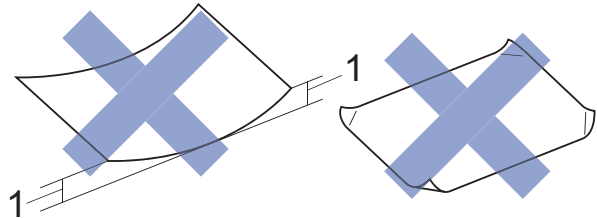

1 2 mm or greater curl may cause jams to occur.

- Extremely shiny or highly textured paper
- Paper that cannot be arranged uniformly when stacked
- Short grain paper

Paper capacity of the output paper tray cover

Up to 50 sheets of 80 g/m² A4 paper.

- Transparencies and photo paper must be picked up from the output paper tray cover one page at a time to avoid smudging.

Choosing the right print media

Paper type and size for each operation

Paper Type	Paper Size		Usage			
			Fax	Copy	Photo Capture	Printer
Cut-Sheet	A3	297 × 420 mm (11.7 × 16.5 in.)	Yes	Yes	Yes	Yes
	A4	210 × 297 mm (8.3 × 11.7 in.)	Yes	Yes	Yes	Yes
	Ledger	279.4 × 431.8 mm (11 × 17 in.)	Yes	Yes	Yes	Yes
	Letter	215.9 × 279.4 mm (8 1/2 × 11 in.)	Yes	Yes	Yes	Yes
	Legal	215.9 × 355.6 mm (8 1/2 × 14 in.)	Yes	Yes	–	Yes
	Folio	215.9 × 330.2 mm (8 1/2 × 13 in.)	–	–	–	Yes
	Executive	184 × 267 mm (7 1/4 × 10 1/2 in.)	–	–	–	Yes
	A5	148 × 210 mm (5.8 × 8.3 in.)	–	Yes	–	Yes
	A6	105 × 148 mm (4.1 × 5.8 in.)	–	–	–	Yes
Cards	Photo	10 × 15 cm (4 × 6 in.)	–	Yes	Yes	Yes
	Photo L	89 × 127 mm (3 1/2 × 5 in.)	–	–	–	Yes
	Photo 2L	13 × 18 cm (5 × 7 in.)	–	–	Yes	Yes
	Index Card	127 × 203 mm (5 × 8 in.)	–	–	–	Yes
Envelopes	C5 Envelope	162 × 229 mm (6.4 × 9 in.)	–	–	–	Yes
	DL Envelope	110 × 220 mm (4.3 × 8.7 in.)	–	–	–	Yes
	Com-10	105 × 241 mm (4 1/8 × 9 1/2 in.)	–	–	–	Yes
	Monarch	98 × 191 mm (3 7/8 × 7 1/2 in.)	–	–	–	Yes
Transparencies	A4	210 × 297 mm (8.3 × 11.7 in.)	–	Yes	–	Yes
	Letter	215.9 × 279.4 mm (8 1/2 × 11 in.)	–	Yes	–	Yes
	Legal	215.9 × 355.6 mm (8 1/2 × 14 in.)	–	Yes	–	Yes
	A5	148 × 210 mm (5.8 × 8.3 in.)	–	Yes	–	Yes

Paper orientation and capacity of the paper trays

	Paper size	Paper types	No. of sheets
Paper Tray #1	<Landscape> A4, Letter, Executive <Portrait> A3, Ledger, Legal, Folio, A5, A6, Photo, Photo L, Photo 2L, Index card, Envelopes (C5, Com-10, DL, Monarch)	Plain Paper	250 ¹
		Inkjet Paper	20
		Glossy Paper, Photo	20
		Index Card	30
		Envelopes, Transparencies	10
Paper Tray #2 (MFC-J6720DW)	<Landscape> A4, Letter <Portrait> A3, Legal, Ledger	Plain Paper	250 ¹
Manual Feed Slot	<Landscape> A4, Letter, Executive <Portrait> A3, Ledger, Legal, Folio, A5, A6, Photo, Photo L, Photo 2L, Index card, Envelopes (C5, Com-10, DL, Monarch)	Plain Paper, Inkjet Paper, Glossy Paper, Photo, Envelopes and Transparencies	1

¹ When using 80 g/m² paper.

NOTE

When you choose User Defined in the Paper Size drop-down list of the printer driver, the paper orientation will differ depending on the size and thickness of the paper.

(For details, see *Paper orientation using User Defined as the Paper Size in the printer driver* on page 43.)

Paper orientation using User Defined as the Paper Size in the printer driver

	User Defined Size	Paper Orientation
Paper Tray #1	When both of the following conditions are satisfied: <ul style="list-style-type: none"> ■ Width: 148.0 mm – 215.9 mm ■ Height: 216.0 mm – 297.0 mm 	Landscape
	When any one of the following conditions is satisfied: <ul style="list-style-type: none"> ■ Width: less than 148.0 mm ■ Width: greater than 215.9 mm ■ Height: less than 216.0 mm ■ Height: greater than 297.0 mm 	Portrait
Manual Feed Slot	When both of the following conditions are satisfied: <ul style="list-style-type: none"> ■ Width: 127.0 mm – 215.9 mm ■ Height: 216.0 mm – 297.0 mm 	Landscape
	When any one of the following conditions is satisfied: <ul style="list-style-type: none"> ■ Width: less than 127.0 mm ■ Width: greater than 215.9 mm ■ Height: less than 216.0 mm ■ Height: greater than 297.0 mm 	Portrait

NOTE

- When choosing Envelope in the Paper Thickness drop-down list, you must load the envelopes in Portrait orientation.
- Tray #2 cannot be used for user defined paper sizes.

Paper weight and thickness

Paper Type		Weight	Thickness
Cut-Sheet	Plain Paper	64 to 120 g/m ²	0.08 to 0.15 mm
	(Tray #2) Plain Paper	64 to 105 g/m ²	0.08 to 0.15 mm
	Inkjet Paper	64 to 200 g/m ²	0.08 to 0.25 mm
	Glossy Paper ¹	Up to 220 g/m ²	Up to 0.25 mm
Cards	Photo Card ¹	Up to 220 g/m ²	Up to 0.25 mm
	Index Card	Up to 120 g/m ²	Up to 0.15 mm
Envelopes		80 to 95 g/m ²	Up to 0.52 mm
Transparencies		–	–

¹ BP71 (260 g/m²) paper is especially designed for Brother inkjet machines.

3

Loading documents

How to load documents

You can send a fax, make copies, or scan from the ADF (automatic document feeder) and from the scanner glass.

Using the ADF

The ADF can hold up to 35 pages and feeds each sheet individually. Use paper that is within the sizes and weights shown in the table. Always fan the edges of the pages before placing them in the ADF.

Document Sizes and Weights

Length:	148 to 431.8 mm
Width:	148 to 297 mm
Weight:	64 to 90 g/m ²

How to load documents

IMPORTANT

- DO NOT pull on the document while it is feeding.
- DO NOT use paper that is curled, wrinkled, folded, ripped, stapled, paper clipped, glued or taped.
- DO NOT use cardboard, newspaper or fabric.

Make sure documents written with ink or modified with correction fluid are completely dry.

- 1 Unfold the ADF Document Support (1) and the ADF Document Output Support Flap (2).

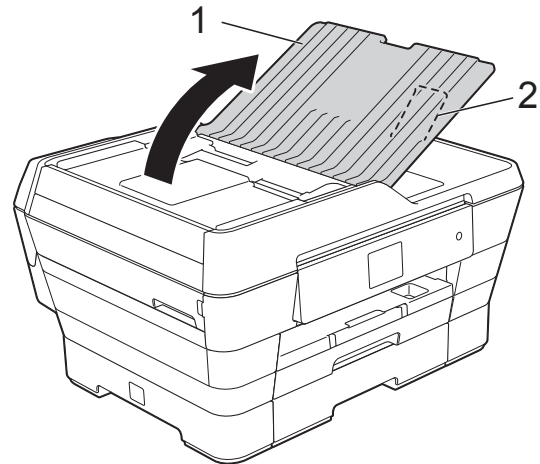

- 2 Fan the pages well.
- 3 Adjust the paper guides (1) to fit the width of your documents.

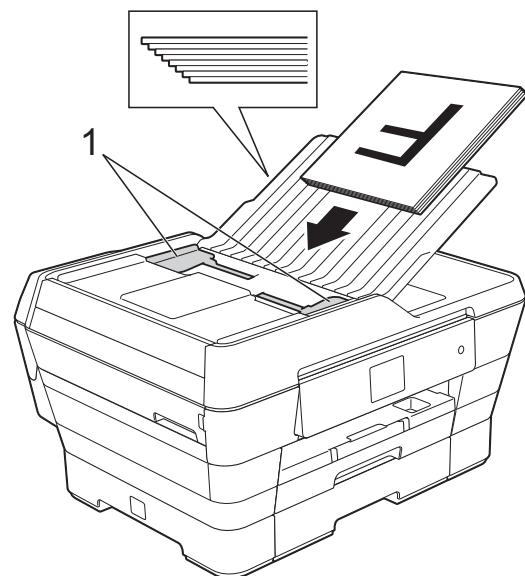

- 4 Place your documents in the ADF **face up, short edge first** until you feel them touch the feed rollers.

The Touchscreen will display
ADF Ready.

■ **When using ADF High Speed Mode in Copy and Scan mode**

Make sure your document size is A4 or Letter.

Place your documents in the ADF **face up, long edge first** until you feel them touch the feed rollers.

The Touchscreen will display
ADF Ready.

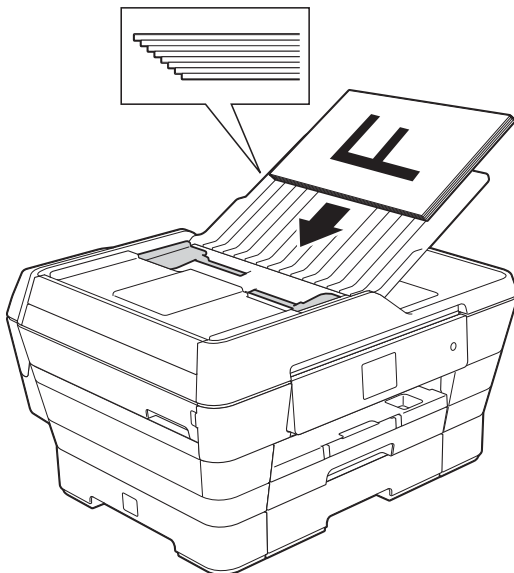

NOTE

ADF High Speed Mode is available with Copy and Scan mode. For more information about ADF High Speed Mode, see the following:

- (Copy)
ADF High Speed Mode copying
on page 78
- (Scan)
ADF High Speed Mode scanning
on page 93

IMPORTANT

DO NOT leave thick documents on the scanner glass. If you do this, the ADF may jam.

Using the scanner glass

You can use the scanner glass to fax, copy or scan single pages or pages of a book.

Document Sizes Supported

Length:	Up to 431.8 mm
Width:	Up to 297 mm
Weight:	Up to 2 kg

How to load documents

NOTE

To use the scanner glass, the ADF must be empty.

- 1 Lift the document cover.

- Using the document guidelines on the left and top, place the document **face down** in the upper left corner of the scanner glass.

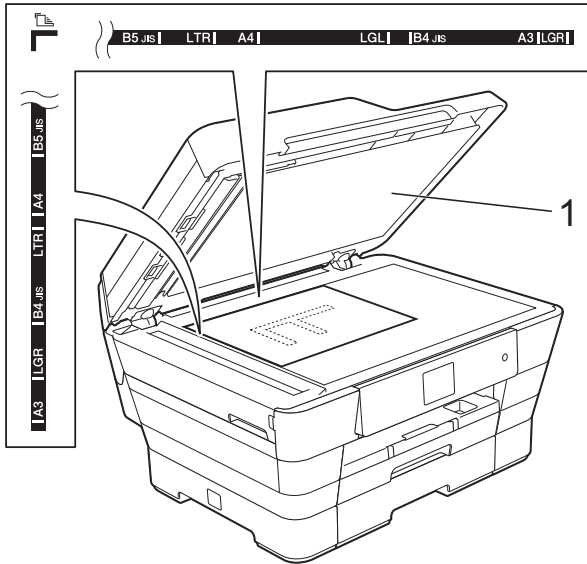

1 document cover

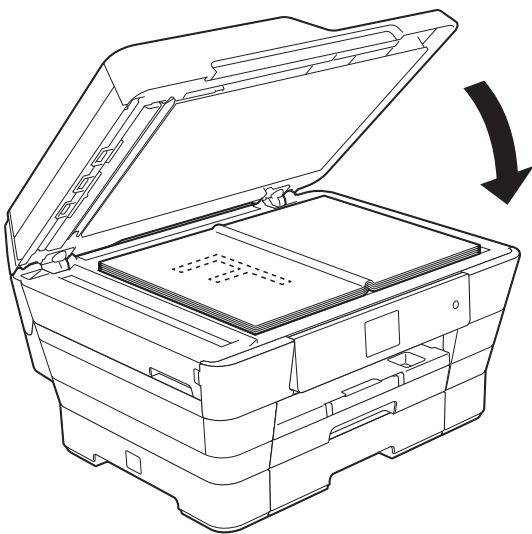

- Close the document cover.

IMPORTANT

If you are scanning a book or thick document, **DO NOT** slam the cover down or press on it.

Unscannable area

The scannable area depends on the settings in the application you are using. The figures show the unscannable areas.

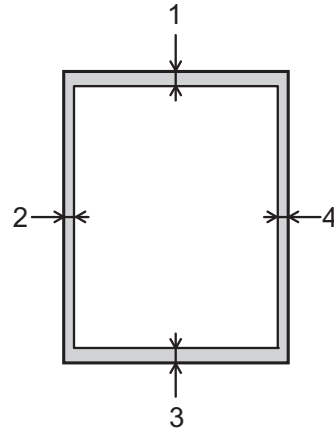

Usage	Document Size	Top (1) Bottom (3)	Left (2) Right (4)
Fax	A3	3 mm	4.5 mm
	A4		3 mm ¹
	Ledger		3.7 mm
	Letter		4 mm
	Legal		
Copy	All paper sizes		3 mm
Scan		2 mm	2 mm

¹ The unscannable area is 1 mm when you use the ADF.



How to send a fax

The following steps show how to send a fax.

- 1 Do one of the following to load your document:
 - Place the document *face up* in the ADF. (See *Using the ADF* on page 44.)
 - Load your document *face down* on the scanner glass. (See *Using the scanner glass* on page 45.)

NOTE

- To send colour faxes with multiple pages, use the ADF.
- If you send a mono fax from the ADF when the memory is full, it will be sent in real time.
- You can use the scanner glass to fax pages of a book one at a time. The documents can be up to A3 or Ledger size.
- Since you can only scan one page at a time, it is easier to use the ADF if you are sending a multiple-page document.

- 2 Do one of the following:
 - When Fax Preview is set to `Off`, press  (Fax).
 - When Fax Preview is set to `On`, press  (Fax) and then  (Sending Faxes).
- The Touchscreen shows:

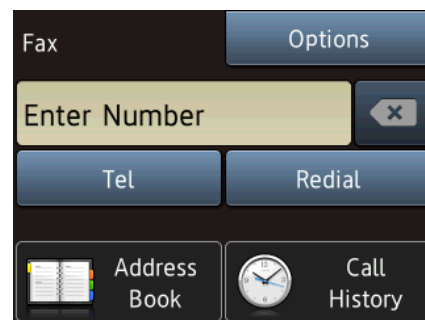

- 3 You can change the following fax-sending settings. Press `Options`. Press `▲` or `▼` to scroll through the fax settings. When the setting you want is displayed, press it and choose your new option. When you have finished changing options, press `OK`.

(Basic User's Guide)

For information about changing the following fax-sending settings, see pages 49 to 51.

- Glass Scan Size
- Colour Fax Transmission
- Preview Outgoing Fax
- Transmission Verification Report (Setup)

(Advanced User's Guide)

For more advanced fax-sending operations and settings (see Advanced User's Guide: *Sending a fax*).

- Contrast
- Fax Resolution
- Set New Defaults
- Factory Reset
- Faxing at the end of a call
- Broadcasting
- Real Time Transmission
- Overseas Mode
- Delayed Fax
- Batch Transmission
- Cancelling Waiting Jobs
- Polled Transmit

- 4 Enter the fax number.

Using the dial pad

Using  (Address Book)

- Address Book

Using  (Call History)

- Outgoing Call
- Caller ID history

NOTE

- You can preview a fax message before sending it by setting *Preview* to *On*. (See *How to preview an outgoing fax* on page 50.)
- If your network supports the LDAP protocol you can search for fax numbers and E-mail addresses on your server. (See *Software and Network User's Guide*.)

- 5 Press *Fax Start*.

Faxing from the ADF

- The machine starts scanning the document to be sent.

Faxing from the scanner glass

- If you choose *Mono* in the *Colour Setting* (default setting), the machine starts scanning the first page. Go to step 6.
- If you choose *Colour* in the *Colour Setting*, the Touchscreen asks if you want to send a colour fax. Press *Yes (Colour fax)* to confirm. The machine starts dialling and sending the document.

- 6 When the Touchscreen asks you *Next page?*, do one of the following:

- To send a single page, press *No*. The machine starts sending the document.
- To send more than one page, press *Yes* and go to step 7.



- 7 Place the next page on the scanner glass. Press *OK*. The machine starts scanning the page. (Repeat steps 6 and 7 for each additional page.)

Stop faxing

To stop faxing, press .

Setting scanner glass size for faxing

When documents are Letter size, you need to set the Scan Size to `Letter`. If you do not, the side portion of the faxes will be missing.

- 1 Load your document.
- 2 Do one of the following:
 - When Fax Preview is set to `Off`, press  (`Fax`).
 - When Fax Preview is set to `On`, press  (`Fax`) and then  (`Sending Faxes`).
- 3 Press `Options`.
- 4 Press `▲` or `▼` to display `Glass Scan Size`.
- 5 Press `Glass Scan Size`.
- 6 Press `▲` or `▼` to display `A4`, `A3`, `Letter`, `Legal` or `Ledger`, and then press the option you want to set.
- 7 Press `OK`.
- 8 Enter the fax number.
- 9 Press `Fax Start`.



NOTE

- You can save the setting you use most often by setting it as the default setting. (See *Advanced User's Guide: Setting your changes as a new default.*)
- This setting is only available for sending documents from the scanner glass.

Colour fax transmission

Your machine can send a colour fax to machines that support this feature.

Colour faxes cannot be stored in the machine's memory. When you send a colour fax, the machine will send it in real time (even if `Real Time TX` is set to `Off`).



- 1 Load your document.
- 2 Do one of the following:
 - When Fax Preview is set to `Off`, press  (`Fax`).
 - When Fax Preview is set to `On`, press  (`Fax`) and then  (`Sending Faxes`).
- 3 Press `Options`.
- 4 Press `▲` or `▼` to display `Colour Setting`.
- 5 Press `Colour Setting`.
- 6 Press `Colour`.
- 7 Press `OK`.
- 8 Enter the fax number.
- 9 Press `Fax Start`.







Cancelling a fax in process

If you want to cancel a fax while the machine is scanning, dialling or sending, press .

How to preview an outgoing fax

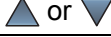
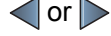
You can preview a fax message before you send it. You must set Real Time Transmission and Polling RX to **Off** before you use this feature.

- 1 Load your document.
- 2 Do one of the following:
 - When Fax Preview is set to **Off**, press  (Fax).
 - When Fax Preview is set to **On**, press  (Fax) and then  (Sending Faxes).
- 3 Press **Options**.
- 4 Press **▲** or **▼** to display **Preview**.
- 5 Press **Preview**.
- 6 Press **On**.
- 7 Press **OK**.
- 8 Enter the fax number using the dial pad or Address Book.
- 9 Press **Fax Start**.
The machine starts scanning the document and the outgoing fax appears on the Touchscreen.
When the fax is displayed, press the Touchscreen to perform the following operations.

	Description
	Enlarge the fax.
	Reduce the fax.
	Scroll vertically.
	Scroll horizontally.
	Rotate the fax clockwise.
	Go back to the previous page.
	Go to the next page.

- 10 Press **Start**.

NOTE

- To send a colour fax, do not use Fax Preview.
- The fax message in the memory will be sent, and then erased when you press **Start**.

Transmission Verification Report

You can use the Transmission Verification Report as proof that you sent a fax. This report lists the sender's name or fax number, the time and date of the transmission, duration of the transmission, number of pages sent, and whether or not the transmission was successful.

There are several settings available for the Transmission Verification Report:

- **On:** Prints a report after every fax you send.
- **On+Image:** Prints a report after every fax you send. A portion of the fax's first page appears on the report.
- **Off:** Prints a report if your fax is unsuccessful due to a transmission error. The report will also print if the receiving machine modifies the size of the document you fax. *Off* is the default setting.
- **Off+Image:** Prints a report if your fax is unsuccessful due to a transmission error. The report will also print if your fax is successful, but the receiving machine modifies the size of the document you fax. A portion of the fax's first page appears on the report.
- **Off2:** Prints a report *only* if your fax is unsuccessful due to a transmission error.
- **Off2+Image:** Prints a report *only* if your fax is unsuccessful due to a transmission error. A portion of the fax's first page appears on the report.

1 Press  (Settings).

2 Press All Settings.

3 Press ▲ or ▼ to display Fax.

4 Press Fax.

5 Press ▲ or ▼ to display Report Setting.

6 Press Report Setting.

7 Press XMIT Report.

8 Press ▲ or ▼ to display On, On+Image, Off, Off+Image, Off2 or Off2+Image and then press the option you want to set.

9 Press .

NOTE

- If you choose On+Image, Off+Image or Off2+Image the image will only appear on the Transmission Verification Report if Real Time Transmission is set to *Off*. The image will not appear on the report when you send a colour fax. (See Advanced User's Guide: *Real Time Transmission*.)
- If your transmission is successful, OK will appear next to RESULT on the Transmission Verification Report. If the transmission is not successful, ERROR will appear next to RESULT.

5

Receiving a fax

Receive Modes

You must choose a Receive Mode depending on the external devices and telephone services you have on your line.

Choose the Receive Mode

By default, your machine will automatically receive any faxes that are sent to it. The diagram below will help you choose the correct receive mode.

For more detailed information on the Receive Modes, see *Using Receive Modes* on page 54.

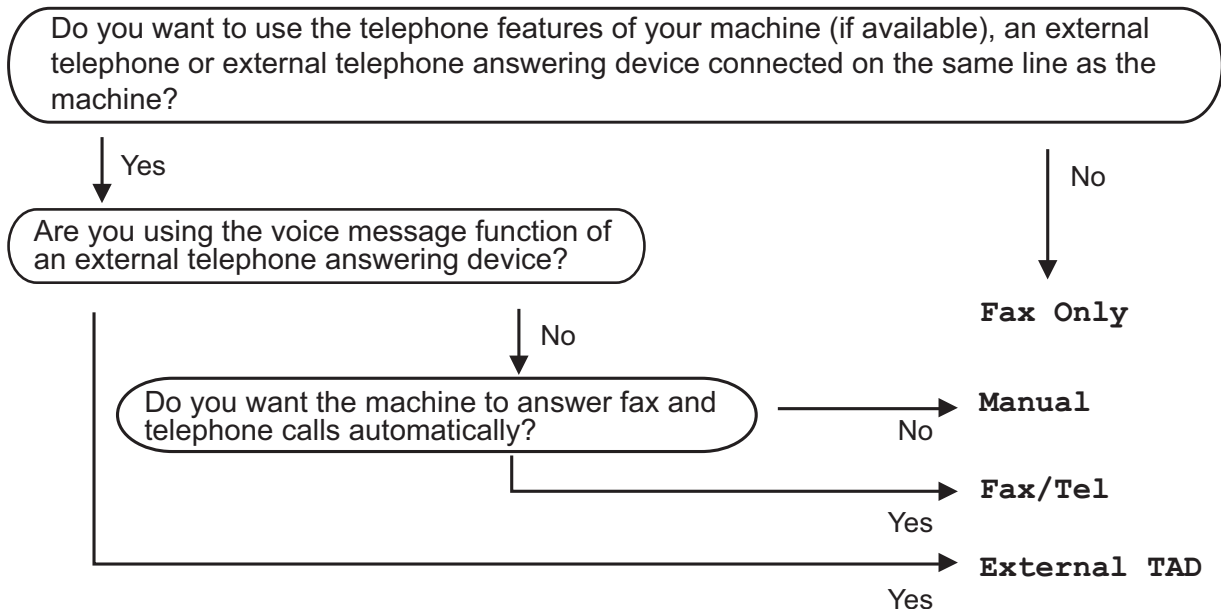

To set the Receive Mode follow the instructions:

- 1 Press  (Settings).
- 2 Press All Settings.
- 3 Press ▲ or ▼ to display Fax.
- 4 Press Fax.
- 5 Press ▲ or ▼ to display Setup Receive.
- 6 Press Setup Receive.
- 7 Press ▲ or ▼ to display Receive Mode.

- 8 Press **Receive Mode**.

NOTE

If the option to change the receive mode is unavailable, make sure the BT Call Sign feature is set to **Off**. (See *Advanced User's Guide: To enable the machine to work with BT Call Sign (with your external telephone only)*.)

- 9 Press **▲** or **▼** to display **Fax Only**, **Fax/Tel**, **External TAD** or **Manual**, and then press the option you want.
- 10 Press .

Using Receive Modes

Some Receive Modes answer automatically (*Fax Only* and *Fax/Tel*). You may want to change the Ring Delay before using these modes. (See *Ring Delay* on page 55.)

Fax Only

Fax Only mode will automatically answer every call as a fax call.

Fax/Tel

Fax/Tel mode helps you manage incoming calls by recognising whether they are fax or voice calls and dealing with them in one of the following ways:

- Faxes will be automatically received.
- Voice calls will start the F/T Ring to tell you to pick up the line. The F/T Ring is a fast double-ring made by your machine.

If you use *Fax/Tel* mode, see *F/T Ring Time (Fax/Tel mode only)* on page 55 and *Ring Delay* on page 55.

Manual

Manual mode turns off all automatic answering functions unless you are using the BT Call Sign feature.

To receive a fax in *Manual* mode, lift the handset of an external telephone. When you hear fax tones (short repeating beeps), press *Fax Start* and choose *Receive*. You can also use the Fax Detect feature to receive faxes by lifting a handset on the same line as the machine.

(See *Fax Detect* on page 56.)

External TAD

External TAD mode lets an external answering device manage your incoming calls. Incoming calls will be dealt with in one of the following ways:

- Faxes will be automatically received.
- Voice callers can record a message on the external TAD.



To connect your External TAD, see *Connecting an external TAD (telephone answering device)* on page 66.

Receive Mode settings

Ring Delay

Ring Delay sets the number of times the machine rings before it answers in Fax Only or Fax/Tel mode. If you have external or extension telephones on the same line as the machine, choose the maximum number of rings.

(See *Operation from external and extension telephones* on page 68 and *Fax Detect* on page 56.)

- 1 Press  (Settings).
- 2 Press All Settings.
- 3 Press ▲ or ▼ to display Fax.
- 4 Press Fax.
- 5 Press ▲ or ▼ to display Setup Receive.
- 6 Press Setup Receive.
- 7 Press ▲ or ▼ to display Ring Delay.
- 8 Press Ring Delay.
- 9 Press the number of times you want the machine to ring before it answers. If you choose 0, the machine will answer immediately and the line will not ring at all.
- 10 Press .



F/T Ring Time (Fax/Tel mode only)

When somebody calls your machine, you and your caller will hear the normal telephone ring. The number of rings is set by the ring delay setting.

If the call is a fax, then your machine will receive it. However, if it is a voice call then the machine will sound the F/T Ring (a fast double-ring) for the time you have set in the F/T Ring Time setting. If you hear the F/T Ring, it means that you have a voice caller on the line.

Because the F/T Ring is made by the machine, extension and external telephones will not ring. However, you can still answer the call on any telephone by using a remote code.

(For more information, see *Using remote codes* on page 69.)

- 1 Press  (Settings).
- 2 Press All Settings.
- 3 Press ▲ or ▼ to display Fax.
- 4 Press Fax.
- 5 Press ▲ or ▼ to display Setup Receive.
- 6 Press Setup Receive.
- 7 Press ▲ or ▼ to display F/T Ring Time.
- 8 Press F/T Ring Time.
- 9 Press how long the machine will ring to alert you that you have a voice call (20Secs, 30Secs, 40Secs or 70Secs).
- 10 Press .

NOTE

Even if the caller hangs up during the fast double-ring, the machine will continue to ring for the set time.

Fax Detect**If Fax Detect is On:**

The machine receives a fax call automatically, even if you answer the call. When you see *Receiving* on the Touchscreen or when you hear “chirps” through the handset you are using, just replace the handset. Your machine will do the rest.

If Fax Detect is Off:

If you are at the machine and answer a fax call by lifting the handset, press *Fax Start*, then press *Receive* to receive the fax.

If you answered at an extension or external telephone, press * **5 1**. (See *Operation from external and extension telephones* on page 68.)

NOTE

- If this feature is set to *On*, but your machine does not connect a fax call when you lift an extension or external telephone handset, press the remote activation code * **5 1**.
- If you send faxes from a computer on the same telephone line and the machine intercepts them, set *Fax Detect* to *Off*.

- 6 Press *Setup Receive*.
- 7 Press ▲ or ▼ to display *Fax Detect*.
- 8 Press *Fax Detect*.
- 9 Press *On (or Off)*.
- 10 Press .

1 Press  (*Settings*).

2 Press *All Settings*.



3 Press ▲ or ▼ to display *Fax*.

4 Press *Fax*.



5 Press ▲ or ▼ to display *Setup Receive*.

Fax Preview (Monochrome faxes only)

How to preview a received fax

You can view received faxes on the Touchscreen by pressing  (Fax) and then  (Received Faxes). When the machine is in Ready mode, a pop-up message will appear on the Touchscreen to alert you of new faxes.

Setting Fax Preview

- 1 Press  (Settings).
- 2 Press  (Fax Preview).
- 3 Press On (or Off).
- 4 Press Yes.
- 5 The Touchscreen will tell you that any future faxes will not be printed as you receive them.
Press Yes (or No).
- 6 Press .

NOTE



When Fax Preview is turned on, a backup copy of received faxes will not be printed for Fax Forwarding and PC-Fax Receiving operations, even if you have set Backup Print to On.

Using Fax Preview

When you receive a fax, you will see a pop-up message on the Touchscreen. (For example: New Fax(es) : 01 [View])

- 1 Press View.
The Touchscreen will display the fax list.

NOTE









- The fax list includes old and new faxes. New faxes are indicated by a blue mark.
- If you want to see a fax that has already been previewed, press  (Fax) and  (Received Faxes).

- 2 Press ▲ or ▼ to display the fax number of the fax you want to see.
- 3 Press the fax you want to see.

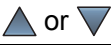
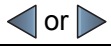
NOTE





- If your fax is large there may be a delay before it is displayed.
- The Touchscreen will show the current page number and total pages of the fax message. When your fax message is over 99 pages the total number of pages will be shown as "XX".

Press the Touchscreen or Touchpanel to perform the following operations.



	Description
	Enlarge the fax.
	Reduce the fax.
	Scroll vertically.
	Scroll horizontally.
	Rotate the fax clockwise.
	Delete the fax. Press Yes to confirm.
	Go back to the previous page.
	Go to the next page.
	Go back to the fax list.
	Print the fax. Do one of the following: <ul style="list-style-type: none"> ■ Press Print All Pages to print the whole fax message. ■ Press Print Displayed Only to only print the displayed page. ■ Press Print From Displayed to print from the displayed page to the last page.

4 Press .



How to print a fax

- 1 Press  (Fax).
- 2 Press  (Received Faxes).
- 3 Press the fax you want to view.
- 4 Press .
 - If the fax is multiple pages, go to step 5.
 - If the fax is a single page, it will start printing. Go to step 6.
- 5 Do one of the following:
 - Press **Print All Pages** to print all pages of the fax. Go to step 6.
 - Press **Print Displayed Only** to print the displayed page. Go to step 7.
 - Press **Print From Displayed** to print from the displayed page to the last page. Go to step 7.
- 6 Do one of the following:
 - To delete the fax, press **Yes**.
 - To keep the fax in the memory, press **No**.
- 7 Press .



How to print all faxes in the list

- 1 Press  (Fax).
- 2 Press  (Received Faxes).
- 3 Press `Print/Delete`.
- 4 Do one of the following:
 - To print all new faxes, press `▲` or `▼` to display `Print All (New Faxes)`. Press `Print All (New Faxes)`.
 - To print all old faxes, press `▲` or `▼` to display `Print All (Old Faxes)`. Press `Print All (Old Faxes)`.
- 5 Press .

How to delete all faxes in the list

- 1 Press  (Fax).
- 2 Press  (Received Faxes).
- 3 Press `Print/Delete`.
- 4 Do one of the following:
 - To delete all new faxes, press `▲` or `▼` to display `Delete All (New Faxes)`. Press `Delete All (New Faxes)`.
 - To delete all old faxes, press `▲` or `▼` to display `Delete All (Old Faxes)`. Press `Delete All (Old Faxes)`.
- 5 Press `Yes` to confirm.
- 6 Press .

Turning off Fax Preview

- 1 Press  (Settings).
- 2 Press  (Fax Preview).
- 3 Press `Off`.
- 4 Press `Yes` to confirm.
- 5 If there are faxes stored in the memory, do one of the following:
 - If you do not want to print the stored faxes, press `Continue`. The machine asks you to confirm the deletion of the stored faxes. Press `Yes` to confirm. Your faxes will be deleted.
 - If you want to print all the stored faxes, press `Print All Faxes Before Delete`.
 - If you do not wish to turn off Fax Preview, press `Cancel`.
- 6 Press .

6

Using PC-FAX

PC-FAX Sending

You can send a file created in any application on your PC as a standard fax.

NOTE

The PC-FAX software can only send monochrome fax documents.

Sending a file as a PC-FAX

Please install MFL-Pro Suite software, connect your machine and PC before using PC-FAX sending.

- 1 Create a file in any application on your PC.
- 2 Click **File**, then **Print**. The **Print** dialog box appears.
- 3 Choose **Brother PC-FAX** as your printer, and then click **Print**. The PC-FAX sending dialog box appears:

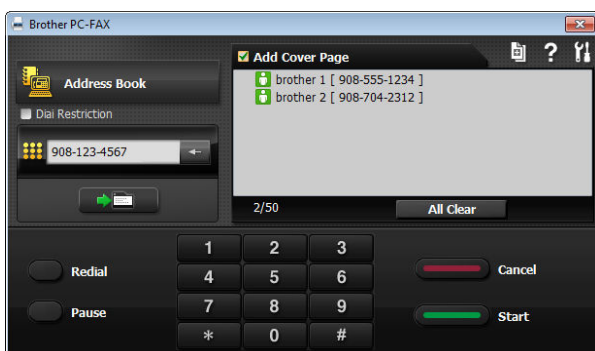

- 4 Enter a fax number using any of the following methods:
 - Use the dial pad to enter the number.

NOTE

If you select the **Dial Restriction** check box, a confirmation dialog box will appear for you to re-enter the fax number. This feature helps to prevent transmissions to the wrong destination.

- Click the **Address Book** button, and then choose a member or group from the Address Book.

If you make a mistake, click **All Clear** to delete all the entries.

- 5 To include a cover page, click **Add Cover Page**.

NOTE

You can also click the cover page  icon to create or edit a cover page.

- 6 Click **Start** to send the fax.

NOTE

- If you want to cancel the fax, click **Cancel**, or press  on the Touchpanel.
- If you want to redial a number, click **Redial** to scroll through the last five fax numbers, choose a number, and then click **Start**.

PC-FAX Receiving (Windows®)

If you turn on the PC-FAX Receive feature, your machine will store received faxes in the memory and send them to your PC. You can then use your PC to view and store these faxes.

Even if you have turned off your PC (at night or on the weekend, for example), your machine will receive and store your faxes in its memory.

When you start your PC and the PC-FAX Receiving software runs, your machine transfers your faxes to your PC.

To transfer the received faxes to your PC you must have the PC-FAX Receiving software running on your PC.

Do one of the following:

(Windows® XP, Windows Vista® and Windows® 7)

From  (**Start**), select **All Programs**, **Brother, MFC-XXXX, PC-FAX Receiving**, and select **Receive**. (where XXXX is your model name.)

(Windows® 8)

Click  (**Brother Utilities**), and then click the drop-down list and select your model name (if not already selected). Click **PC-FAX Receive** in the left navigation bar, and then click **Receive**.

If you choose **Backup Print: On**, the machine will also print the fax.

- 1 Press  (Settings).
- 2 Press **All Settings**.
- 3 Press **▲** or **▼** to display **Fax**.
- 4 Press **Fax**.

- 5 Press **▲** or **▼** to display **Setup Receive**.
- 6 Press **Setup Receive**.
- 7 Press **▲** or **▼** to display **Memory Receive**.
- 8 Press **Memory Receive**.
- 9 Press **▲** or **▼** to display **PC Fax Receive**.
- 10 Press **PC Fax Receive**.
- 11 The Touchscreen shows the message **Run PC-Fax on your computer. Press OK**.
- 12 Press **▲** or **▼** to display **<USB>** or the name of the PC you want to receive faxes if you are on a network. Press **<USB>** or the name of the PC. Press **OK**.
- 13 If **Fax Preview** is set to **Off**, press **Backup Print: On** or **Backup Print: Off**.
- 14 Press .

NOTE

- PC-FAX Receive is not supported by Mac OS.
- Before you can set up PC-FAX Receive, you must install the MFL-Pro Suite software on your PC. Make sure your PC is connected and turned on.

(See Software and Network User's Guide.)

- If you get an error message and the machine cannot print the faxes in the memory, you can use this setting to transfer your faxes to your PC. (See *Transferring your faxes or Fax Journal report* on page 114.)
 - When you receive a colour fax, your machine prints the colour fax at your machine but does not send the fax to your PC.
 - To change the destination PC, repeat steps ① to ⑭.
-

Voice operations

Fax/Tel mode

When the machine is in Fax/Tel mode, it will use the F/T Ring (fast double-ring) to alert you to pick up a voice call.

If you are at an external telephone, lift the handset of the external telephone, and then press **Pickup** to answer.

If you are at an extension telephone, you'll need to lift the handset during the F/T Ring Time and then press **# 5 1** between the fast double-rings. If no one is on the line, or if someone wants to send you a fax, send the call back to the machine by pressing *** 5 1**.

Caller ID (U.K. and Ireland only)

The Caller ID feature lets you use the Caller ID subscriber service offered by many local telephone companies. Call your telephone company for details. This service shows the telephone number, or name if it is available, of your caller as the line rings.

After a few rings, the Touchscreen shows the telephone number of your caller (and name, if available). Once you answer a call, the Caller ID information disappears from the Touchscreen, but the call information stays stored in the Caller ID memory.

You can view the list or choose one of these numbers to fax to, add to Address Book, or delete from the history. (See *Caller ID history* on page 73.)

- The **ID Unknown** message means the call originated outside your Caller ID service area.
- The **ID Withheld** message means the caller has intentionally blocked the transmission of their information.



You can print a list of the Caller ID information received by your machine. (See *Advanced User's Guide: How to print a report.*)

NOTE

The Caller ID service varies with different carriers. Call your local telephone company to find out about the kind of service available in your area.

Setting the Caller ID to On

If you have Caller ID on your line, then this function should be set to **On** to display the caller's telephone number on the Touchscreen as the telephone rings.

- 1 Press  (Settings).
- 2 Press **All Settings**.
- 3 Press **▲** or **▼** to display **Fax**.
- 4 Press **Fax**.
- 5 Press **▲** or **▼** to display **Miscellaneous**.
- 6 Press **Miscellaneous**.
- 7 Press **Caller ID**.
- 8 Press **On** (or **Off**).
- 9 Press .

Telephone services

Your machine supports the Caller ID subscriber telephone service that some telephone companies offer.

Features like Voice Mail, Call Waiting, Call Waiting/Caller ID, answering services, alarm systems or other custom features on one telephone line may create problems with the operation of your machine.

NOTE

Caller ID is available for U.K. and Ireland only.

Setting the Telephone Line Type

If you are connecting the machine to a line that features PBX or ISDN to send and receive faxes, it is also necessary to change the Telephone Line Type accordingly by completing the following steps:

- 1 Press  (Settings).
- 2 Press `All Settings`.
- 3 Press `▲` or `▼` to display `Initial Setup`.
- 4 Press `Initial Setup`.
- 5 Press `▲` or `▼` to display `Phone Line Set`.
- 6 Press `Phone Line Set`.
- 7 Press `Normal`, `PBX` or `ISDN`.
- 8 Do one of the following:
 - If you choose `PBX`, go to step 9.
 - If you choose `ISDN` or `Normal`, go to step 12.

- 9 Press `On` or `Always`.

NOTE

If you choose `On`, the machine dials a prefix number before the fax number you dial only when `R` is pressed.

If you choose `Always`, the machine always automatically dials a prefix number before the fax number.

- 10 Press `Dial Prefix`.

- 11 Enter the prefix number using the keyboard on the Touchscreen.
Press `OK`.

NOTE

You can use the numbers 0 to 9, #, * and !. You cannot use ! with any other numbers or characters.

- 12 Press .

PBX and TRANSFER

The machine is initially set to `Normal`, which lets the machine connect to a standard PSTN (Public Switched Telephone Network) line. However, many offices use a central telephone system or Private Branch Exchange (PBX). Your machine can be connected to most types of PBX. The machine's recall feature supports timed break recall only (TBR). TBR will work with most PBX systems allowing you to gain access to an outside line, or transfer calls to another extension. The feature works when the `R` on the Touchscreen is pressed.

NOTE

You can program a press of the **R** button as part of a number stored in Address Book. When programming the Address Book number, press **R** first (the Touchscreen shows '!'), then enter the telephone number. If you do this, you do not need to press **R** each time before you dial using an Address Book. (See *Storing numbers* on page 74.) However, if your Telephone Line Type is not set to PBX on the machine, you cannot use the Address Book number that the **R** is programmed into.

Voice over Internet Protocol (VoIP)

VoIP is a type of phone system that uses an Internet connection instead of a traditional telephone line. Telephone providers frequently bundle VoIP together with Internet and cable services.

Your machine may not work with some VoIP systems. If you want to use your machine to send and receive faxes on a VoIP system, make sure that one end of your telephone cord is connected to the socket labelled **LINE** on your machine. The other end of the telephone cord may be connected to a modem, phone adapter, splitter, or other such device.

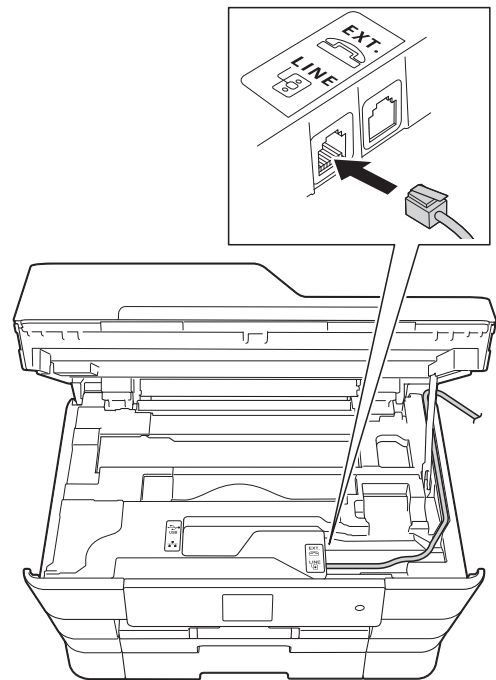

- **If you have questions about how to connect your machine to the VoIP system, please contact your VoIP provider.**

After you have connected your machine to the VoIP system, check for a dial tone. Lift the external telephone's handset and listen for a dial tone. If there is no dial tone, please contact your VoIP provider.

If you are having problems sending or receiving faxes over a VoIP system, we recommend changing the machine's modem speed to the **Basic (for VoIP)** setting (see *Telephone line interference / VoIP* on page 135).

Connecting an external TAD (telephone answering device)

You may choose to connect an external answering device. However, when you have an **external** TAD on the same telephone line as the machine, the TAD answers all calls and the machine “listens” for fax calling (CNG) tones. If it hears them, the machine takes over the call and receives the fax. If it does not hear CNG tones, the machine lets the TAD continue playing your outgoing message so your caller can leave a voice message.

The TAD must answer within four rings (the recommended setting is two rings). The machine cannot hear CNG tones until the TAD has answered the call, and with four rings, there are only 8 to 10 seconds of CNG tones left for the fax “handshake”. Make sure you carefully follow the instructions in this guide for recording your outgoing message. We do not recommend using the toll saver feature on your external answering machine if it exceeds five rings.

NOTE

If you do not receive all your faxes, shorten the Ring Delay setting on your external TAD.

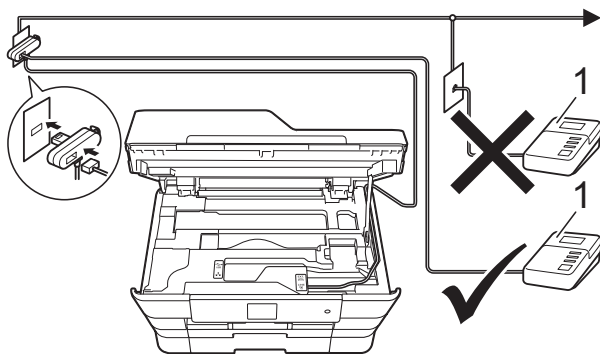

1 TAD

When the TAD answers a call, the Touchscreen shows `Telephone`.

IMPORTANT

DO NOT connect a TAD elsewhere on the same telephone line.

Connection settings

The external TAD must be connected as shown in the previous illustration.

- 1 Using both hands, use the finger holds on each side of the machine to lift the scanner cover into the open position.
- 2 Carefully guide the telephone line cord into the cable channel and out the back of the machine.
- 3 Lift the scanner cover to release the lock. Gently push the scanner cover support down and close the scanner cover using both hands.
- 4 Set your external TAD to one or two rings. (The machine's Ring Delay setting does not apply.)
- 5 Record the outgoing message on your external TAD.
- 6 Set the TAD to answer calls.
- 7 Set the Receive Mode to `External TAD`. (See *Choose the Receive Mode* on page 52.)

Recording an outgoing message (OGM) on an external TAD

Timing is important in recording this message.

- 1 Record 5 seconds of silence at the beginning of your message. (This allows your machine time to listen for the fax CNG tones of automatic transmissions before they stop.)
- 2 Limit your speaking to 20 seconds.

NOTE

We recommend beginning your OGM with an initial 5 second silence because the machine may not hear the fax tones over a voice. You may try omitting this pause, but if your machine has trouble receiving, then you must re-record the OGM to include it.

Multi-line connections (PBX)

We suggest you ask the company who installed your PBX to connect your machine. If you have a multi-line system, we suggest you ask the installer to connect the unit to the last line on the system. This prevents the machine being activated each time the system receives telephone calls. If all incoming calls will be answered by a switchboard operator, we recommend that you set the Receive Mode to *Manual*.

We cannot guarantee that your machine will operate correctly under all circumstances when connected to a PBX. Any difficulties with sending or receiving faxes should be reported first to the company who handles your PBX.

NOTE

Make sure the Telephone Line Type is set to PBX. (See *Setting the Telephone Line Type* on page 64.)

External and extension telephones

Connecting an external or extension telephone

You can connect a separate telephone to your machine as shown in the diagram.

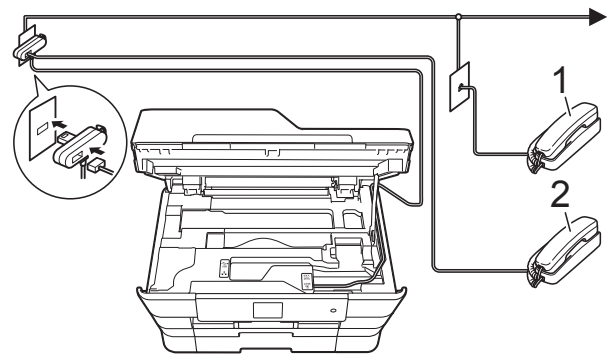

- 1 Extension telephone
- 2 External telephone

NOTE

Please make sure you use an external telephone with a cable no more than 3 metres long.

Operation from external and extension telephones

If you answer a fax call on an extension or an external telephone, you can make your machine take the call by using the Remote Activation Code. When you press the Remote Activation Code * 5 1, the machine starts to receive the fax.

If the machine answers a voice call and fast double-rings for you to take over, use the Remote Deactivation Code # 5 1 to take the call at an extension telephone. (See *F/T Ring Time (Fax/Tel mode only)* on page 55.)

If you answer a call and no one is on the line:

Assume you are receiving a manual fax.

Press * 5 1 and wait for the chirp or until the Touchscreen shows *Receiving*, and then hang up.

NOTE

You can also use the Fax Detect feature to make your machine automatically take the call. (See *Fax Detect* on page 56.)

Using extension telephones (U.K. only)

Your premises may already be wired with parallel extension telephones, or you may plan to add extension telephones to your line, as well as your machine. While the simplest arrangement is a straightforward parallel connection, there are some problems with this. The most obvious is inadvertent interruption of a facsimile transmission caused by someone picking up an extension telephone to make an outgoing call. Also, the remote activation code feature may not operate reliably in such a simple configuration.

This machine may also be set to make a delayed transmission (i.e. a transmission at a pre-set time). This pre-set job may coincide with someone picking up an extension handset.

These problems can easily be eliminated, if you arrange modification of your extension wiring circuit, such that extension devices are connected “downstream” of your machine in a master/slave configuration (see fig. 2). In this configuration the machine can always detect whether a telephone is in use. Thus it will not attempt to seize the line during that time. This is known as “telephone off-hook detection.”

The inadvisable configuration is shown in figure 1, and the recommended master/slave configuration is shown in figure 2.

This new connection configuration can be arranged by contacting BT, Kingston upon Hull Telecommunications, your PBX maintainer or a qualified telephone installation company as appropriate. Simply explained, the extension telephone circuit should be terminated on a normal modular plug (BT 431A style), which in turn should be put into the modular socket of the white “T”-shaped connector provided as part of the line cord assembly.

Inadvisable connection of extension sockets (Fig. 1.)

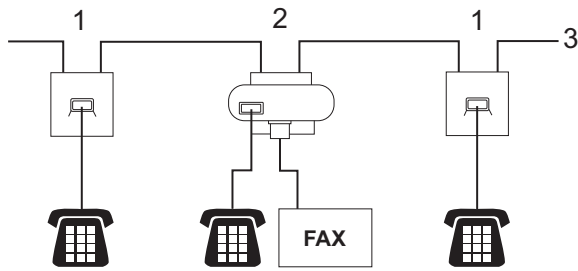

- 1 Extension socket
- 2 Master socket
- 3 Incoming line

Recommended connection of extension sockets (Fig. 2.)

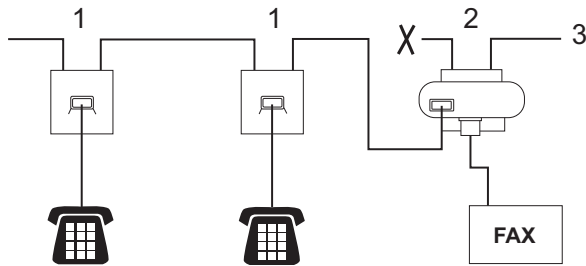

- 1 Extension socket
- 2 Master socket
- 3 Incoming line

The fax machine must be plugged into the master socket.

NOTE

These telephones are now connected as external devices (See *Connecting an external or extension telephone* on page 67), because they are connected to the fax machine via the T-connector.

Using remote codes

Remote Activation Code

If you answer a fax call on an extension or external telephone, you can tell your machine to receive it by dialling the Remote Activation Code * 5 1. Wait for the chirping sounds and then replace the handset. (See *Fax Detect* on page 56.)

If you answer a fax call at the external telephone, you can make the machine receive the fax by pressing *Fax Start* and choose *Receive*.

Remote Deactivation Code

If you receive a voice call and the machine is in Fax/Tel mode, it will start to sound the F/T Ring (fast double-ring) after the initial ring delay. If you pick up the call on an extension telephone, you can turn the F/T Ring off by pressing # 5 1 (make sure you press this *between* the rings).

If the machine answers a voice call and fast double-rings for you to take over, you can take the call at the external telephone by pressing *Pickup*.

Changing the remote codes

If you want to use Remote Activation, you have to turn on the remote codes. The preset Remote Activation Code is * 5 1. The preset Remote Deactivation Code is # 5 1. If you want to, you can replace them with your own codes.

- 1 Press  (Settings).
- 2 Press All Settings.
- 3 Press ▲ or ▼ to display Fax.
- 4 Press Fax.
- 5 Press ▲ or ▼ to display Setup Receive.



- 6 Press **Setup Receive**.
- 7 Press **▲** or **▼** to display **Remote Codes**.
- 8 Press **Remote Codes**.
- 9 Do one of the following:
 - If you want to change the **Remote Activation Code**, press **Act.Code**.
Enter the new code, and then press **OK**.
 - If you want to change the **Remote Deactivation Code**, press **Deact.Code**.
Enter the new code, and then press **OK**.
 - If you do not want to change the **Codes**, go to step 10.
 - If you want to turn the **Remote Codes Off (or On)**, press **Remote Codes**.
Press **Off (or On)**.
- 10 Press .

NOTE

- If you are always disconnected when accessing your external TAD remotely, try changing the **Remote Activation Code** and **Remote Deactivation Code** to another three-digit code using the numbers **0-9**, *****, **#**.
 - **Remote Codes** might not work with some telephone systems.
-

How to dial

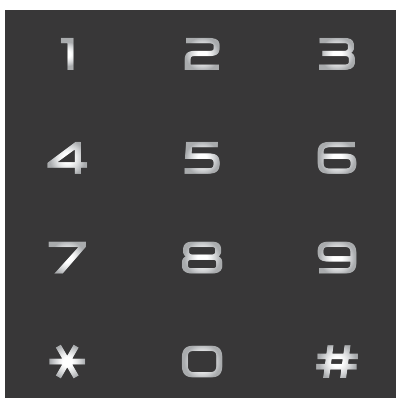

Manual dialling

- 1 Load your document.
- 2 Do one of the following:
 - When Fax Preview is set to Off, press  (Fax).
 - When Fax Preview is set to On, press  (Fax) and then  (Sending Faxes).
- 3 Press all of the digits of the fax number.



- 4 Press Fax Start.

Dialling from the Address Book

- 1 Load your document.
- 2 Press  (Fax).
- 3 Press  (Address Book).
- 4 Do one of the following:
 - Press ▲ or ▼ to display the number you want to dial.
 - Press , and then enter the first letter of the name and press OK. Press the name you want to dial. If the name has two numbers, go to step 5. If the name has one number, go to step 6.

NOTE

If the LDAP search is available, the result will be shown on the Touchscreen with





(For details, see Software and Network User's Guide.)

- 5 Press the number you want to dial.
- 6 To send a fax, press Apply.
- 7 Press Fax Start. The machine scans and sends the fax.

Fax Redial

If you are sending a fax automatically and the line is busy, the machine will redial up to three times at five minute intervals.

- 1 Load your document.
- 2 Do one of the following:
 - When Fax Preview is set to `Off`, press  (Fax).
 - When Fax Preview is set to `On`, press  (Fax) and then  (Sending Faxes).
- 3 Press `Redial`.
- 4 Press `Fax Start`.



NOTE

- In Real Time Transmission the automatic redial feature does not work when you are using the scanner glass.
 - Redial will change to `Pause` when you enter a fax number.
 - Redial only works if you dialed from the machine.
-

Additional Dialling Operations

Outgoing Call history

The last 30 numbers you sent a fax to will be stored in the outgoing call history. You can choose one of these numbers to fax to, add to the Address Book, or delete from the history.

- 1 Press  (Fax).
- 2 Press  (Call History).
- 3 Press `Outgoing Call`.
- 4 Press the number you want.
- 5 Do one of the following:
 - To send a fax, press `Apply`.
Press `Fax Start`.
 - If you want to store the number, press `Edit` and then press `Add to Address Book`.
(See Advanced User's Guide: *Storing Address Book numbers from the Outgoing Call history*.)
 - If you want to delete the number from the Outgoing Call history list, press `Edit` and then press `Delete`.
Press `Yes` to confirm.
Press .



Caller ID history

This feature requires the Caller ID subscriber service offered by many local telephone companies. (See *Caller ID (U.K. and Ireland only)* on page 63.)

The numbers, or names if available, from the last 30 faxes and telephone calls you received will be stored in the Caller ID history. You can view the list or choose one of these numbers to fax to, add to Address Book, or delete from the history. When the thirty-first call comes into the machine, it replaces information about the first call.

NOTE

If you are not a Caller ID subscriber, you can still view call dates from the Caller ID history and delete entries from the list.

- 1 Press  (Fax).
- 2 Press  (Call History).
- 3 Press Caller ID history.
- 4 Press the number or the name you want.
- 5 Do one of the following:
 - To send a fax, press **Apply**.
Press **Fax Start**.
 - If you want to store the number, press **Edit** and then press **Add to Address Book**.
(See *Advanced User's Guide: Storing Address Book numbers from the Caller ID history*.)
 - If you want to delete the number from the Caller ID history list, press **Edit** and then press **Delete**.
Press **Yes** to confirm.
Press .

NOTE

You can print the Caller ID list.
(See *Advanced User's Guide: How to print a report*.)

Storing numbers

You can set up your machine to do the following types of easy dialling: Address Book and Groups for broadcasting faxes.

NOTE



If you lose electrical power, the Address Book numbers that are in the memory will not be lost.

Storing a pause

When you are storing Address Book numbers, you can insert one or more 3.5 second pauses by pressing **Pause** on the Touchscreen.

Storing Address Book numbers

You can store up to 100 Addresses with a name, and each name can have two numbers.

- 1 Press  (Fax).
- 2 Press  (Address Book).
- 3 Press **Edit**.
- 4 Press **▲** or **▼** to display **Add New Address**.
- 5 Press **Add New Address**.
- 6 Press **Name**.
- 7 Enter the name using the keyboard on the Touchscreen (up to 16 characters). Press **OK**.
(For help entering letters, see *Entering Text* on page 186.)
- 8 Press **Address 1**.

- 9 Enter the first fax or telephone number using the keyboard on the Touchscreen (up to 20 digits). Press **OK**.

NOTE

- Be sure to include the area code when entering a fax or telephone number. Depending on the country, the Caller ID names and history may not be displayed correctly if the area code is not registered with the fax or telephone number.
- *If you downloaded the Internet Fax feature:*



If you want to store an E-mail address to use with Internet Fax or Scan to E-mail

server, press  and enter the E-mail address and press **OK**. (See *Entering Text* on page 186.)

- 10 If you want to store a second fax or telephone number, press **Address 2**. Enter the second fax or telephone number using the keyboard on the Touchscreen (up to 20 digits). Press **OK**.
- 11 Press **OK** to confirm.
- 12 Do one of the following:
 - To store another Address Book number, repeat steps 3 to 11.
 - To finish storing numbers, press .

Changing or deleting Address Book names or numbers

You can change or delete an Address Book name or number that has already been stored.

- 1 Press  (Fax).
- 2 Press  (Address Book).
- 3 Press `Edit`.
- 4 Do one of the following:
 - Press `▲` or `▼` to display `Change`.
Press `Change` to edit the name or numbers of an address. Go to step 5.
 - Press `▲` or `▼` to display `Delete`.
Press `Delete`.
Choose the numbers you want to delete by pressing them to display a red check mark.
Press `OK`.
Press `Yes` to confirm. Go to step 9.
- 5 Press `▲` or `▼` to display the number you want to change.
- 6 Press the number you want to change.

- 7 Do one of the following:
 - If you want to change the name, press `Name`.
Enter the new name (up to 16 characters) using the keyboard on the Touchscreen. (For help entering letters, see *Entering Text* on page 186.)
Press `OK`.
 - If you want to change the first fax or telephone number, press `Address 1`.
Enter the new fax or telephone number (up to 20 digits) using the keyboard on the Touchscreen.
Press `OK`.
 - If you want to change the second fax or telephone number, press `Address 2`.
Enter the new fax or telephone number (up to 20 digits) using the keyboard on the Touchscreen.
Press `OK`.

NOTE

How to change the stored name or number:

If you want to change a character or a stored number, press `◀` or `▶` to position the cursor to highlight the character or the number you want to change, and then press . Enter the new character or number.

- 8 Do one of the following:
 - Press `OK` to finish.
To change another Address Book number, repeat steps 3 to 8.
 - To make more changes, return to 7.
- 9 Press .

9

Making copies

How to copy

The following steps demonstrate a basic copy operation.

- 1 Do one of the following to load your document:
 - Place the document *face up* in the ADF.
(See *Using the ADF* on page 44.)
 - Place the document *face down* on the scanner glass.
(See *Using the scanner glass* on page 45.)

- 2 Press  (Copy).

- The Touchscreen shows:



1 No. of Copies

You can enter the number of copies by pressing – or + on the Touchscreen (as shown above) or by using the dial pad.

- 3 If you want more than one copy, enter the number (up to 99).
- 4 Press **Mono Start** or **Colour Start**.

Stop copying

To stop copying, press .

Copy options

You can change the following copy settings.

- 1 Press  (Copy).
- 2 Press **Options**.
- 3 Press **▲** or **▼** to scroll through the copy settings.
When the setting you want is displayed, press it and choose your option.
- 4 When you have finished changing options, press **OK**.

(Basic User's Guide)

For information about changing the following copy settings, see pages 77 to 78.

- Paper Type
- Paper Size
- Tray Select (MFC-J6720DW)
- ADF HighSpeed Mode

(Advanced User's Guide)

For information about changing the following copy settings, see Advanced User's Guide: *Copy options*.

- Quality
- Enlarge/Reduce
- Page Layout
- 2in1 (ID)
- Stack/Sort
- Density
- 2-sided Copy
- Ink Save Mode
- Thin Paper Copy
- Auto Deskew
- Book Copy
- Watermark Copy
- Remove Background Colour
- Set New Default
- Factory Reset

NOTE

If you want to sort copies, use the ADF.

Paper Type

If you are copying on a special type of paper, set the machine for the type of paper you are using to get the best print quality.

- 1 Load your document.
- 2 Press  (Copy).
- 3 Enter the number of copies you want.
- 4 Press **Options**.
- 5 Press **▲** or **▼** to display **Paper Type**.
- 6 Press **Paper Type**.
- 7 Press **▲** or **▼** to display **Plain Paper**, **Inkjet Paper**, **Brother BP71**, **Other Glossy** or **Transparency**, and then press the option you want to set.
- 8 If you do not want to change additional settings, press **OK**.
- 9 Press **Mono Start** or **Colour Start**.

Paper Size

If you are copying on paper other than A4 size, you will need to change the Paper Size setting. You can copy only on A4, A5, A3, Photo (10 × 15 cm), Letter, Legal or Ledger paper.

- 1 Load your document.
- 2 Press  (Copy).
- 3 Enter the number of copies you want.
- 4 Press **Options**.

- 5 Press ▲ or ▼ to display `Paper Size`.
- 6 Press `Paper Size`.
- 7 Press ▲ or ▼ to display `A4`, `A5`, `A3`, `10x15cm`, `Letter`, `Legal` or `Ledger`, and then press the option you want to set.

NOTE

If you are using the manual feed slot insert only one sheet of paper at a time. (See *Loading paper in the manual feed slot* on page 33.)

- 8 If you do not want to change further settings, press `OK`.
- 9 Press `Mono Start` or `Colour Start`.

Tray Select (MFC-J6720DW)

You can change the tray temporarily for the next copy. To change the default tray setting, see *Tray use in Copy mode (MFC-J6720DW)* on page 38.

- 1 Load your document.
- 2 Press  (`Copy`).
- 3 Enter the number of copies you want.
- 4 Press `Options`.
- 5 Press ▲ or ▼ to display `Tray Select`.
- 6 Press `Tray Select`.
- 7 Press `Tray #1`, `Tray #2` or `Auto Tray Select`.
- 8 If you do not want to change additional settings, press `OK`.
- 9 Press `Mono Start` or `Colour Start`.

ADF High Speed Mode copying

When copying multi-page A4 or Letter size documents, you can print multiple copies faster by placing the documents **face up, long edge first** in the ADF. (See *Using the ADF* on page 44.)

- 1 Place your document face up, long side edge first in the ADF.
- 2 Press  (`Copy`).
- 3 Press the `Options`.
- 4 Press ▲ or ▼ to display `ADF HighSpeed Mode`.
- 5 Press `ADF HighSpeed Mode`.
- 6 Press `On` (or `Off`).
- 7 Read the information on the Touchscreen, and then confirm it by pressing `OK`.
- 8 If you do not want to change more settings, press `OK`.

NOTE

Change `Paper Size` to `A4` or `Letter` to match the paper size of your document.

- 9 Press `Mono Start` or `Colour Start`. The machine scans the document and starts printing.

NOTE

`Enlarge/Reduce`, `Page Layout`, `Auto Deskew` and `Advanced Settings` are not available with `ADF HighSpeed Mode`.

PhotoCapture Center™ operations (PHOTO mode)

Even if your machine is *not* connected to your computer, you can print photos directly from digital camera media or a USB Flash drive. (See *Print Images* on page 82.)

You can scan documents and save them directly to a memory card or USB Flash drive. (See *How to scan to a memory card or USB Flash drive* on page 83.)

If your machine is connected to a computer, you can use your computer to access a memory card or USB Flash drive that is inserted in the front of the machine.

(See Software and Network User's Guide.)

Using a memory card or USB Flash drive

Your Brother machine has media drives (slots) for use with the following popular digital camera media: Memory Stick Duo™, Memory Stick PRO Duo™, SD Memory Card, SDHC Memory Card, SDXC Memory Card, MultiMedia Card, MultiMedia Card plus and a USB Flash drive.

The PhotoCapture Center™ feature lets you print digital photos from your digital camera at high resolution to get photo quality printing.

Getting started

- 1 Open the media slot cover.
- 2 Firmly put a memory card or USB Flash drive into the correct slot.

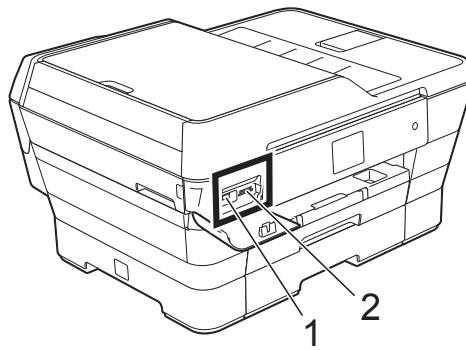



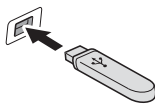

1 USB Flash drive

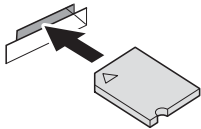

IMPORTANT

The USB direct interface supports only a USB Flash drive, a PictBridge-compatible camera, or a digital camera that uses the USB mass storage standard. Any other USB devices are not supported.

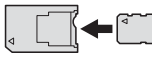
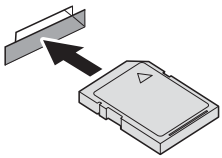
2 Memory card slot

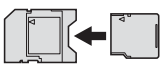
Slot	Compatible memory cards	
Upper slot 		Memory Stick Duo™ Memory Stick PRO Duo™
		Memory Stick Micro™ (M2™) (Adapter required)
Lower slot 		SD Memory Card SDHC Memory Card SDXC Memory Card MultiMedia Card MultiMedia Card plus 
		miniSD (Adapter required) miniSDHC (Adapter required) microSD (Adapter required) microSDHC (Adapter required) MultiMedia Card mobile (Adapter required)

IMPORTANT

- DO NOT insert a Memory Stick Duo™ into the lower SD slot, this may cause damage to the machine.
 - DO NOT insert more than one media card in the machine at the same time. Doing this may cause damage to the machine.
 - DO NOT unplug the power cord or remove the memory card or USB Flash drive from the media drive (slot) or USB direct interface while the machine is reading or writing to the memory card or USB Flash drive. **You will lose your data or damage the card.**
-

The machine can only read one device at a time.

Print Images

View Photos

You can preview your photos on the Touchscreen before you print them. If your photos are large files there may be a delay before each photo is displayed.

- 1 Open the media slot cover.
- 2 Put the memory card or USB Flash drive in the correct slot.
- 3 Press **Photo**.
- 4 Press ◀ or ▶ to display **View Photos**.
- 5 Press **View Photos**.
- 6 Do one of the following:
 - If you want to choose photos to print or print more than one for an image, go to step 7.
 - If you want to print all photos, press **Print All**. Press **Yes** to confirm. Go to step 10.
- 7 Press ◀ or ▶ to display the photo you want to print, and then press it.
- 8 Enter the number of copies you want either by entering the number of copies or by pressing + or -. Press **OK**.
- 9 Repeat steps 7 and 8 until you have chosen all the photos you want to print.
- 10 Press **OK**.
- 11 Read and confirm the displayed list of options and do one of the following:
 - If you want to change the print settings, press **Print Settings**. (See *Advanced User's Guide: PhotoCapture Center™ print settings*.)
 - If you do not want to change any settings, go to step 12.
- 12 Press **Start** to print.

PhotoCapture Center™ print settings

You can temporarily change the print settings for the next print.

The machine returns to its default settings after 1 minute.

NOTE

You can save the print settings you use most often by setting them as the default. (See *Advanced User's Guide: Setting your changes as a new default.*)

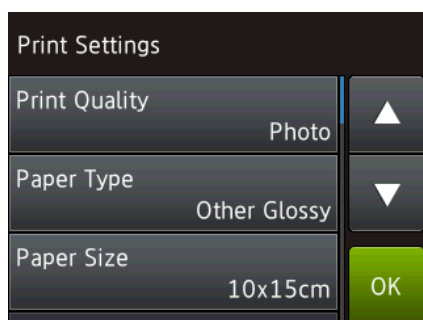

How to scan to a memory card or USB Flash drive

You can scan monochrome and colour documents to a memory card or USB Flash drive. Monochrome documents will be stored in PDF (*.PDF) or TIFF (*.TIF) file formats. Colour documents may be stored in PDF (*.PDF) or JPEG (*.JPG) file formats. The factory setting is **Colour**, 200 dpi and the default format is **PDF**. The machine creates file names based on the current date. (See Quick Setup Guide.) For example, the fifth image scanned on July 1, 2013 would be named 01071305.PDF. You can change the colour and resolution.

- 1 Load your document.
- 2 Open the media slot cover.
- 3 Put the memory card or USB Flash drive in the correct slot.
- 4 Press **Scan to Media**.

IMPORTANT

DO NOT take out the memory card or USB Flash drive while the machine is reading or writing to it to avoid damaging the card, USB Flash drive, or the data stored on them.

- 5 Do one of the following:
 - If you want to use the default settings, go to 10.
 - If you want to change the default settings, go to 6.
- 6 Press **Options**.

- 7 Choose the settings for ADF High Speed Mode, Scan Type, Resolution, File Type, Scan Size, Scan Long Paper, File Name, Auto Crop and Remove Background Colour as required.

NOTE

- If you chose colour in the scan type setting, you cannot choose the file type TIFF.
- If you chose monochrome in the scan type setting, you cannot choose the file type JPEG.
- Scan Long Paper is available only when using the ADF.
- Remove Background Colour removes the base colour of documents to make the scanned data more recognizable.

- 8 The file name is set automatically. However, you can create a name of your choice using the keyboard on the Touchscreen. Press File Name, and then enter the file name. You can only change the first 6 digits of the file name. Press OK.

- 9 Press OK.

NOTE

If you want to save the settings as a shortcut, press Save as Shortcut.

- 10 Press Start. If you are using the scanner glass, the Touchscreen shows Next page?. Press Yes or No. After you finish scanning, make sure you choose No before removing the memory card or USB Flash drive from the machine.

Printing a document

The machine can receive and print data from your computer. To print from a computer, you must install the printer driver.

(For more information, see Software and Network User's Guide.)

- 1 Install the Brother printer driver from the CD-ROM or Brother website.
(See Quick Setup Guide.)
- 2 From your application, choose the **Print** command.
- 3 Choose the name of your machine in the **Print** dialog box and click **Properties** or **Preferences**, depending on the application you are using.
- 4 Choose the settings you want to change in the **Properties** dialog box.
Commonly used settings include:
 - **Media Type**
 - **Print Quality**
 - **Paper Size**
 - **Orientation**
 - **Colour / Greyscale**
 - **Ink Save Mode**
 - **Scaling**
 - **2-sided / Booklet**
- 5 Click **OK**.
- 6 Click **Print** (or **OK** depending on the application you are using) to begin printing.

Before scanning

To use the machine as a scanner, install a scanner driver. If the machine is on a network, configure it with a TCP/IP address.

- Install the scanner drivers from the CD-ROM. (See Quick Setup Guide: *Install MFL-Pro Suite*.)
- Configure the machine with a TCP/IP address if network scanning does not work.
(See Software and Network User's Guide.)



Scanning a document as a PDF file using ControlCenter4 (Windows®)

(For detailed information, see Software and Network User's Guide.)

NOTE

- The screens on your PC may vary depending on your model.
- This section is based on using the Advanced Mode of ControlCenter4.

ControlCenter4 is a software utility that lets you quickly and easily access the applications you use most often. Using ControlCenter4 eliminates the need to manually launch specific applications.

- 1 Load your document. (See *How to load documents* on page 44.)
- 2 (Windows® XP, Windows Vista® and Windows® 7)
Open ControlCenter4 by clicking  (**Start**)/**All Programs**/**Brother**/**MFC-XXXX** (where XXXX is your model name)/**ControlCenter4**. The ControlCenter4 application will open.
(Windows® 8)
Click  (**Brother Utilities**), and then click the drop-down list and select your model name (if not already selected). Click **SCAN** in the left navigation bar, and then click **ControlCenter4**. The ControlCenter4 application will open.
- 3 If the ControlCenter4 Mode screen appears, choose the **Advanced Mode**, and then click **OK**.

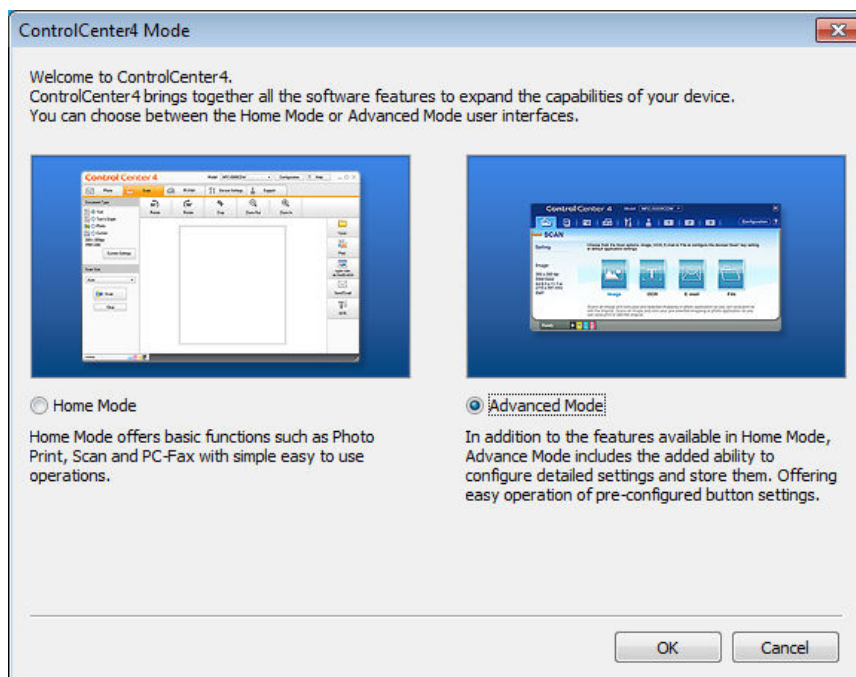

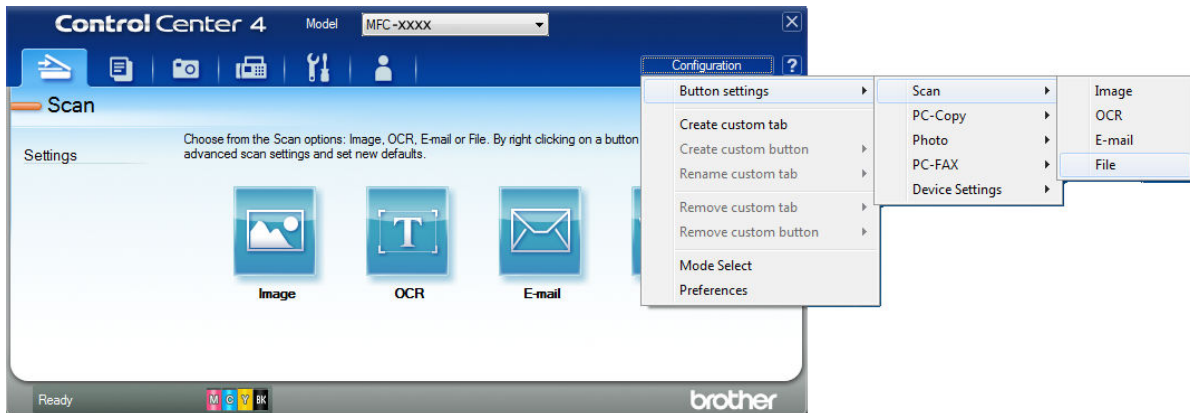

- 4 Make sure the machine you want to use is selected from the **Model** drop-down list.

- 5 Set the scanning configuration.
Click **Configuration**, and then select **Button settings**, **Scan** and **File**.

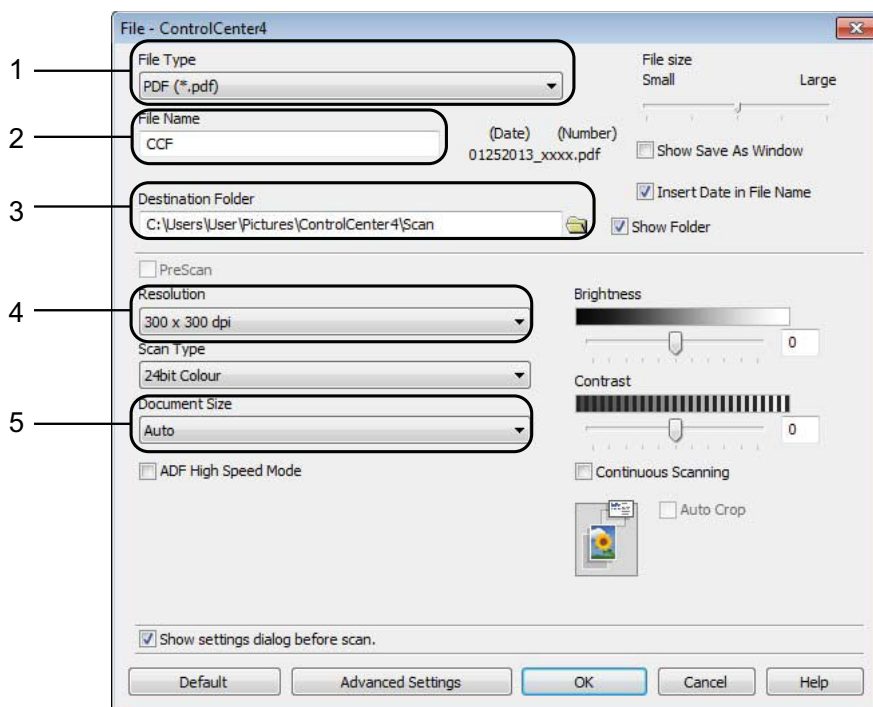

The configuration dialog box appears. You can change the default settings.



- 1 Choose **PDF (*.pdf)** from the **File Type** drop-down list.
- 2 You can enter the file name you want to use for the document.
- 3 You can save the file to the default folder, or choose your preferred folder by clicking the  (**Browse**) button.
- 4 You can choose a scanning resolution from the **Resolution** drop-down list.
- 5 You can choose the document size from the **Document Size** drop-down list.

- 6 Click **OK**.

7 Click **File**.



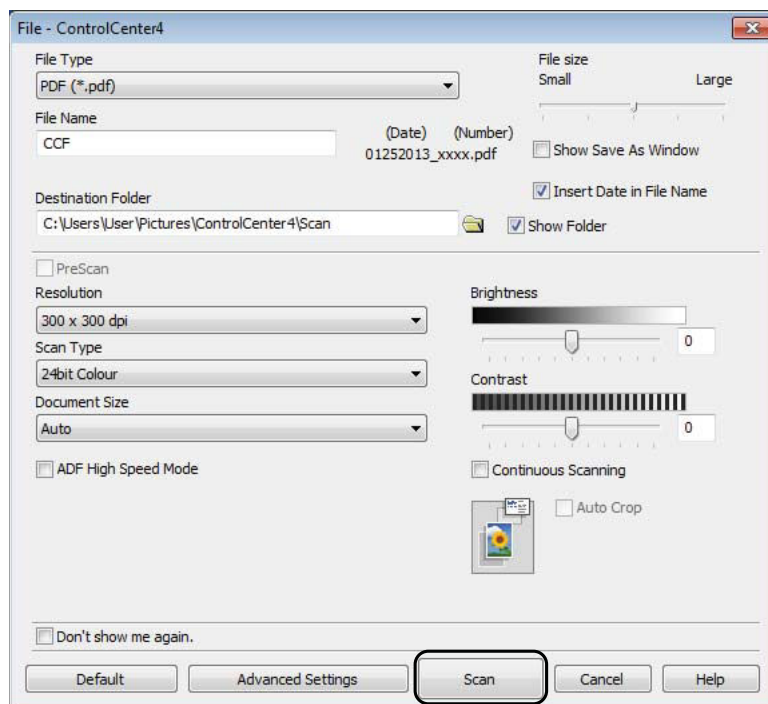

8 Press **Scan**.

The machine starts the scanning process. The folder where the scanned data is saved will open automatically.



How to change the machine's SCAN mode settings for PDF scanning

You can change your machine's `scan` mode settings using ControlCenter4. (Windows®)

- 1 (Windows® XP, Windows Vista® and Windows® 7)
Open ControlCenter4 by clicking  (**Start**)/**All Programs**/**Brother**/**MFC-XXXX** (where XXXX is your model name)/**ControlCenter4**. The ControlCenter4 application will open. (Windows® 8)
Click  (**Brother Utilities**), and then click the drop-down list and select your model name (if not already selected). Click **SCAN** in the left navigation bar, and then click **ControlCenter4**. The ControlCenter4 application will open.
- 2 Make sure the machine you want to use is selected from the **Model** drop-down list.
- 3 Click the **Device Settings** tab.
- 4 Click **Device Scan Settings**.



- 5 Choose the **File** tab. You can change the default settings.

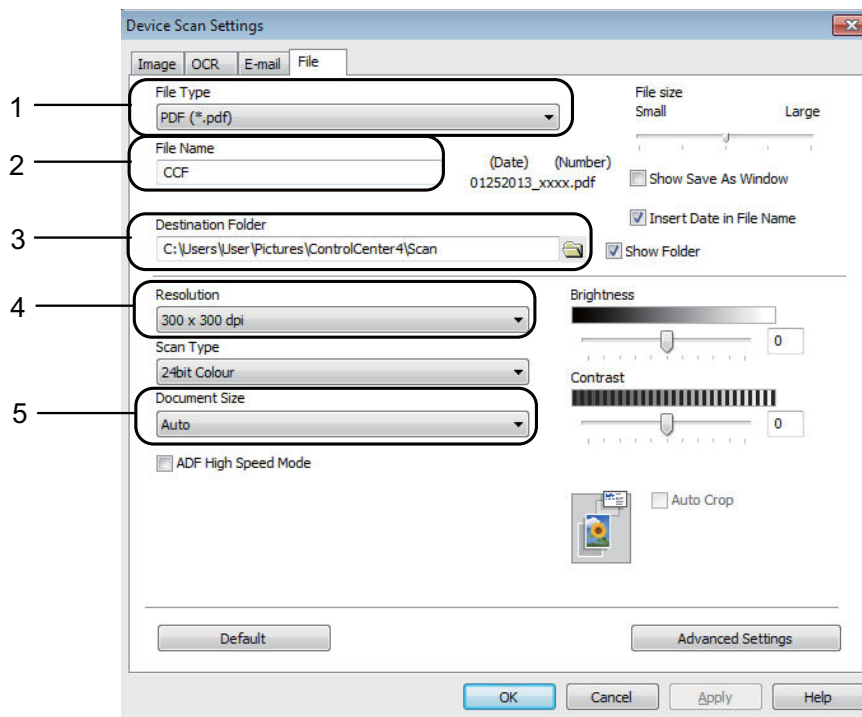

- 1 Choose **PDF (*.pdf)** from the **File Type** drop-down list.
- 2 You can enter the file name you want to use for the document.
- 3 You can save the file to the default folder, or choose your preferred folder by clicking the  (**Browse**) button.
- 4 You can choose a scanning resolution from the **Resolution** drop-down list.
- 5 You can choose the document size from the **Document Size** drop-down list.

- 6 Click **OK**.

How to scan a document as a PDF file using the Touchscreen

- 1 Load your document. (See *How to load documents* on page 44.)
- 2 Press  (Scan).
- 3 Press ◀ or ▶ to display to File.
- 4 Press to File.
- 5 If the machine is connected to a network, press the PC Name.
Do one of the following:
 - If you want to use the default settings, go to step 10.
 - If you want to change the default settings, go to step 6.
- 6 Press Options.
- 7 Press Set with Touch Panel.
Press On.
- 8 Choose the settings for ADF High Speed Mode, Scan Type, Resolution, File Type, Scan Size, and Remove Background Colour as required.
- 9 Press OK.
- 10 Press Start.
The machine starts the scanning process.

NOTE

The following scan modes are available.

- to OCR
- to File
- to Image
- to Media
- to E-mail
- to E-mail Server
- to FTP
- to Network
- WS Scan¹ (Web Services Scan)

¹ Windows® users only. (Windows Vista® SP2 or later, Windows® 7 and Windows® 8)
(See Software and Network User's Guide.)

ADF High Speed Mode scanning

When scanning multi-page A4 or Letter size documents, you can scan faster by placing them **face up, long edge first** in the ADF. (See *How to load documents* on page 44.)

- 1 Place your document in the ADF face up, long edge first.
If you want to scan to a memory card or USB Flash drive, open the media slot cover and put the memory card or USB Flash drive in the correct slot.
- 2 Press  (Scan).
- 3 Press ◀ or ▶ to display to OCR, to File, to Image, to Media, to E-mail, to E-mail Server, to FTP or to Network and press the option you want to use.
- 4 When the machine is connected to a network, press the PC name.
- 5 Press Options.
For to OCR, to File, to Image and to E-mail, press Set with Touch Panel, and then press On.
- 6 Press ADF High Speed Mode.
- 7 Press On (or Off).
- 8 Read the information on the Touchscreen, and then confirm it by pressing OK.
- 9 If you do not want to change more settings, press OK.

NOTE

Change Scan Size to A4 or Letter to match the size of your document.

- 10 Press Start.
The machine starts scanning the document.

NOTE

- Auto Crop and Scan Long Paper are not available with ADF High Speed Mode.
 - The Scan Size options will be limited to A4 and Letter when using ADF High Speed Mode.
-

A

Routine maintenance

Replacing the ink cartridges

Your machine is equipped with an ink dot counter. The ink dot counter monitors the level of ink in each of the four cartridges. When the machine detects an ink cartridge is running out of ink, the machine will display a message.

The Touchscreen will show which ink cartridge is low or needs replacing. Be sure to follow the Touchscreen prompts to replace the ink cartridges in the correct order.

Even though the machine tells you to replace an ink cartridge, there will be a small amount of ink left in the ink cartridge. It is necessary to keep some ink in the ink cartridge to prevent air from drying out and damaging the print head assembly.

⚠ CAUTION

If ink gets in your eyes, wash it out with water at once and call a doctor if you are concerned.

IMPORTANT

Brother multifunction machines are designed to work with ink of a particular specification and will work to a level of optimum performance and reliability when used with Brother Original ink cartridges. Brother cannot guarantee this optimum performance and reliability if ink or ink cartridges of other specifications are used. Brother does not therefore recommend the use of cartridges other than Brother Original cartridges or the refilling of used cartridges with ink from other sources. Damage to the product caused by the use of consumables manufactured by third parties may not be covered by the product warranty. Please refer to the terms of the product warranty.

- 1 Open the ink cartridge cover (1). If one or more of the ink cartridges have reached the end of their life, the Touchscreen shows
B&W 1-sided Print Only or
Cannot Print.

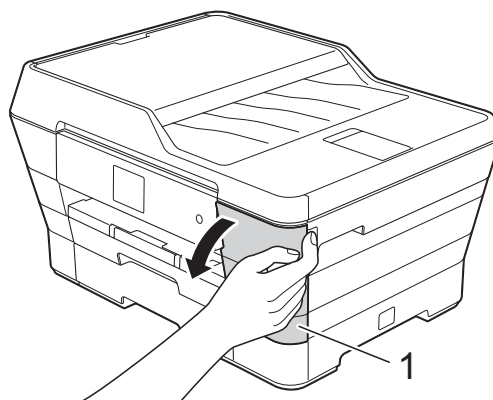

- 2 Press the lock release lever as shown to release the cartridge indicated on the Touchscreen. Remove the cartridge from the machine.

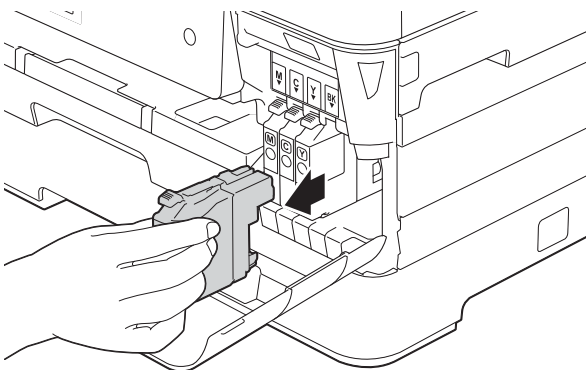
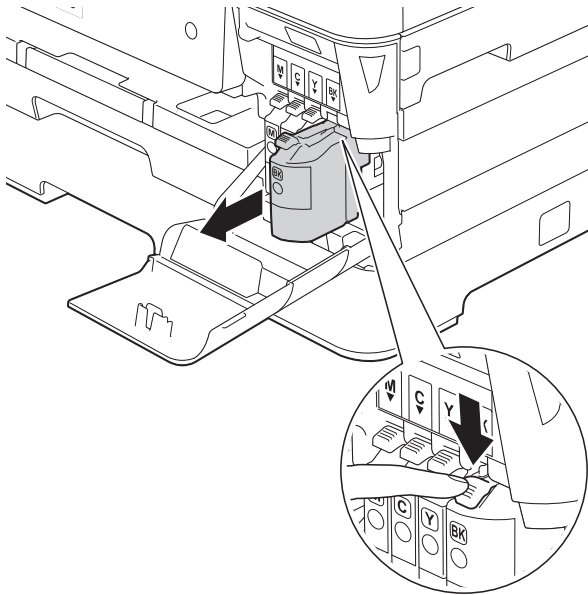

- 3 Open the new ink cartridge bag for the colour indicated on the Touchscreen, and then take out the ink cartridge.

- 4 Turn the green release lever on the orange protective packing (1) counterclockwise until it releases the vacuum seal. Then remove the orange protective packing as shown.

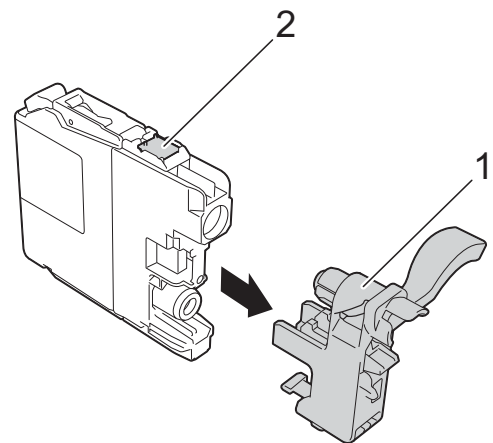
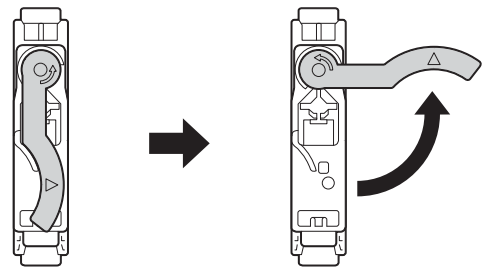
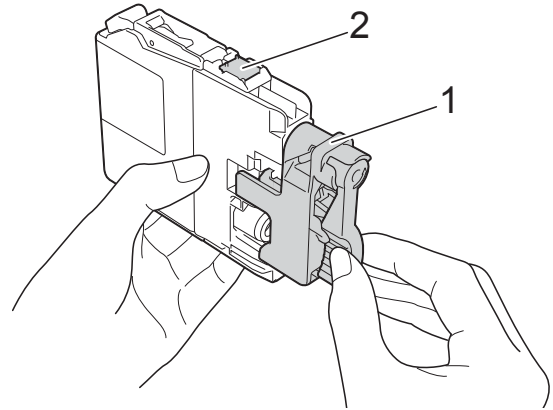

IMPORTANT

DO NOT touch the cartridge in the area indicated (2); this can prevent the machine from detecting the cartridge.

- 5 Each colour has its own correct position. Insert the ink cartridge in the direction of the arrow on the label.

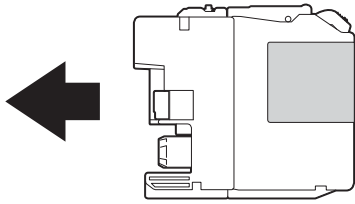

- 6 Gently push the back of the ink cartridge marked PUSH until the cartridge lever lifts, and then close the ink cartridge cover.

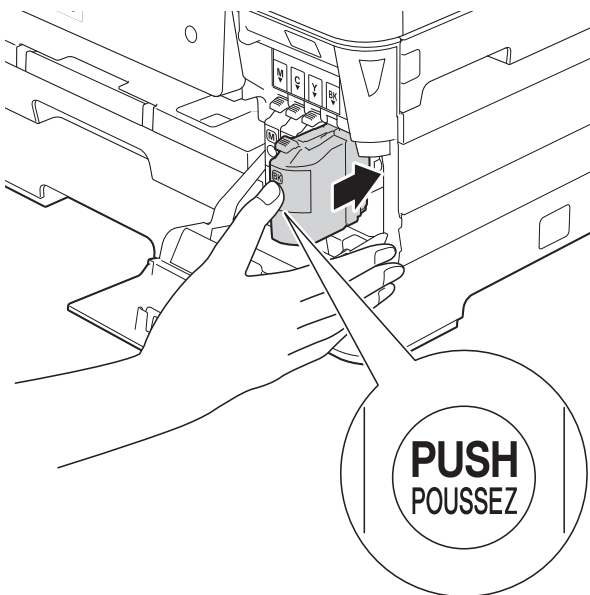

- 7 The machine will automatically reset the ink dot counter.

NOTE

- If you replaced an ink cartridge, the Touchscreen may ask you to verify that it was a brand new one (for example, Did you change **BK** Black). For each new cartridge you installed, press **Yes** to reset the ink dot counter for that colour. If the ink cartridge you installed is not a brand new one, be sure to press **No**.
- If the Touchscreen shows **No Ink Cartridge** or **Cannot Detect** after you install the ink cartridge, check that the ink cartridge is a brand new Brother Original cartridge and that it is installed correctly. Remove the ink cartridge and reinstall it slowly and firmly until the cartridge lever lifts.

IMPORTANT

- DO NOT take out ink cartridges if you do not need to replace them. If you do so, it may reduce the ink quantity and the machine will not know the quantity of ink left in the cartridge.
- DO NOT touch the cartridge insertion slots. If you do so, the ink may stain your skin.
- DO NOT shake the ink cartridges. If ink gets on your skin or clothing, immediately wash it off with soap or detergent.
- If you mix the colours by installing an ink cartridge in the wrong position, the Touchscreen shows **Wrong Ink Colour**. Check which ink cartridges are not matched by colour to their ink cartridge positions and move them to their correct positions.
- Once you open an ink cartridge, install it in the machine and use it up within six months of installation. Use unopened ink cartridges by the expiration date written on the cartridge package.
- DO NOT dismantle or tamper with the ink cartridge; this can cause the ink to leak out of the cartridge.

Cleaning and checking the machine

Cleaning the scanner glass

- 1 Unplug the machine from the electrical socket.
- 2 Lift the document cover (1). Clean the scanner glass (2) and the white plastic (3) with a soft lint-free cloth moistened with a non-flammable glass cleaner.

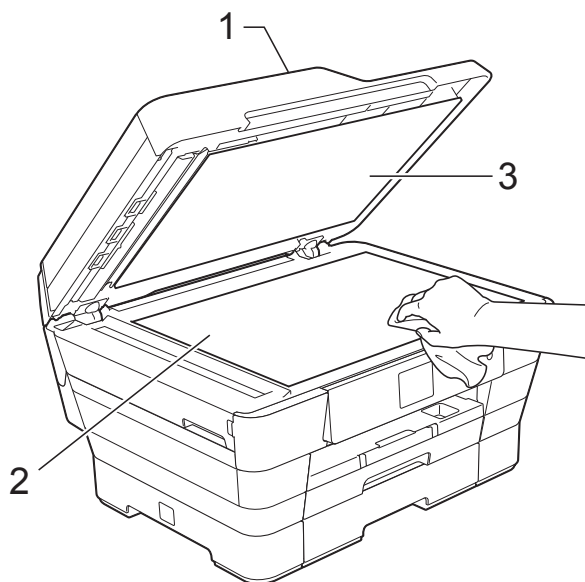

- 3 In the ADF unit, clean the white bar (1) and the glass strip (2) with a lint-free cloth moistened with a non-flammable glass cleaner.

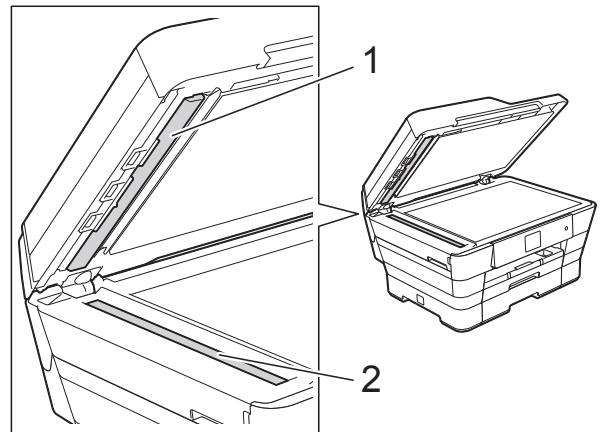

NOTE

In addition to cleaning the glass strip with a non-flammable glass cleaner, run your finger tip over the glass strip to see if you can feel anything on it. If you feel dirt or debris, clean the glass strip again concentrating on that area. You may need to repeat the cleaning process three or four times. To test, make a copy after each cleaning attempt.



When there is a spot of dirt or correction fluid on the glass strip, the printed sample shows a vertical line.



After the glass strip is cleaned, the vertical line is gone.

Cleaning the print head

To maintain good print quality, the machine will automatically clean the print head when needed. You can start the cleaning process manually if there is a print quality problem.

Clean the print head if you get a horizontal line in the text or graphics, or blank text on your printed pages. You can clean Black only; Yellow, Cyan, and Magenta at once; or all four colours at once.

Cleaning the print head consumes ink. Cleaning too often uses ink unnecessarily.

IMPORTANT

DO NOT touch the print head. Touching the print head may cause permanent damage and may void the print head's warranty.

1 Press .

NOTE

You can also press  (Settings) and then Ink.

2 Press **Cleaning**.

3 Press **Black**, **Colour** or **All**.
The machine cleans the print head. When cleaning is finished, the machine will go back to the Ready mode.

NOTE

- If you clean the print head at least five times and the print has not improved, try installing a new Brother Original Innobella™ ink cartridge for each problem colour. Try cleaning the print head again up to five more times. If the print has not improved, contact Brother customer service or your local Brother dealer.

- You can also clean the print head from your PC.

(See Software and Network User's Guide.)

Checking the print quality

If faded or streaked colours and text appear on your printouts, some of the print head nozzles may be clogged. You can check this by printing the Print Quality Check Sheet and looking at the nozzle check pattern.

1 Press .

NOTE

You can also press  (Settings) and then Ink.

2 Press **Test Print**.

3 Press **Print Quality**.

4 Press **OK**.
The machine begins printing the Print Quality Check Sheet.

5 Check the quality of the four colour blocks on the sheet.

- 6 The Touchscreen asks you if the print quality is OK.
Do one of the following:
- If all lines are clear and visible, press **Yes** to finish the Print Quality check and go to step 10.
 - If you can see missing short lines as shown below, press **No**.

OK

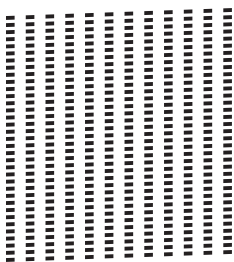

Poor

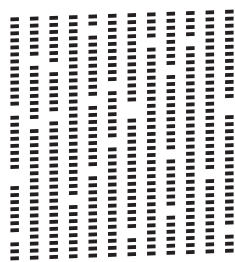

- 7 The Touchscreen asks you if the print quality is OK for black and then the three colours.
Press **Yes** or **No**.
- 8 The Touchscreen asks you if you want to start cleaning.
Press **OK**.
The machine starts cleaning the print head.
- 9 After the cleaning procedure is finished, press **OK**.
The machine prints the Print Quality Check Sheet again. Return to step 6.
- 10 Press .

If you clean the print head at least five times and the print has not improved, try installing a new Brother Original Innobella™ replacement ink cartridge for each problem colour. Try cleaning the print head up to five more times. If the print has not improved, contact Brother customer service or your local Brother dealer.

IMPORTANT

DO NOT touch the print head. Touching the print head may cause permanent damage and may void the print head's warranty.

NOTE

When a print head nozzle is clogged, the printed sample looks like this.



A4, Letter and Executive



A3, Ledger, Legal, Folio, A5, A6, Envelopes, Photo (10 × 15 cm), Photo L (89 × 127 mm), Photo 2L (13 × 18 cm) and Index Card (127 × 203 mm)

After the print head nozzle is cleaned, the horizontal lines are gone.



Checking the print alignment

If your printed text becomes blurred or images become faded, you may need to adjust the print alignment after transporting the machine.

- 1 Press .

NOTE

You can also press  (Settings) and then Ink.

- 2 Press `Test Print`.
- 3 Press `Alignment`.
- 4 Press `OK`.
The machine starts printing the Alignment Check Sheet.

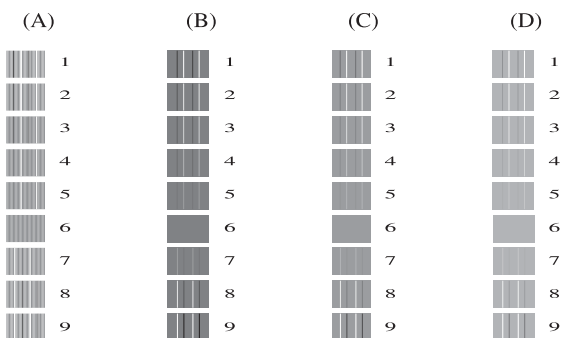

- 5 For the "A" pattern, press ▲ or ▼ to display the number of the test print that has the least visible vertical stripes (1-9), and then press it.
Press `OK`.
Repeat this step for the B, C and D patterns.
In the example, number 6 is the best choice for A, B, C and D.

NOTE

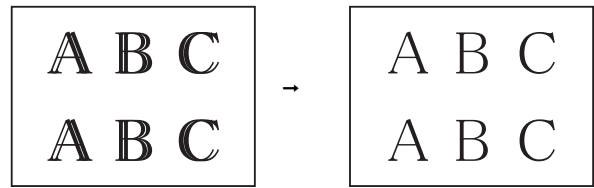

When the print alignment is not adjusted correctly, text looks blurry like this.



After the print alignment is adjusted correctly, text looks like this.

- 6 Press .

Setting the date and time

The Touchscreen displays the date and time. If it is not current, follow these instructions to re-enter it.

You can add the date and time to each fax you send by setting your Station ID.

- 1 Press  (Settings).
- 2 Press All Settings.
- 3 Press ▲ or ▼ to display Initial Setup.
- 4 Press Initial Setup.
- 5 Press ▲ or ▼ to display Date & Time.
- 6 Press Date & Time.
- 7 Press Date.
- 8 Enter the last two digits of the year on the Touchscreen, and then press OK.
- 9 Enter the two digits for the month on the Touchscreen, and then press OK.
- 10 Enter the two digits for the day on the Touchscreen, and then press OK.
- 11 Press Time.
- 12 Enter the time (in 24-hour format) using the keyboard on the Touchscreen. Press OK.
(For example, enter 19:45 for 7:45 PM.)
- 13 Press .

B

Troubleshooting

If you think there is a problem with your machine, check each of the items below first and follow the troubleshooting tips.

You can correct most problems by yourself. If you need additional help, the Brother Solutions Center offers the latest FAQs and troubleshooting tips.

Visit us at <http://solutions.brother.com/>.

Identifying your problem

First, check the following:

- The machine's power cord is connected correctly and the machine's power switch is turned on.
- All of the protective parts have been removed.
- Paper is inserted correctly in the paper tray.
- The interface cables are securely connected to the machine and the computer, or the wireless connection is set up on both the machine and your computer.
- Touchscreen Messages

(See *Error and maintenance messages* on page 104.)

If you did not solve your problem with the above checks, identify your problem and then go to the suggested page.

Paper handling and Printing problems:

- *Printing Difficulties* on page 123
- *Print Quality Difficulties* on page 125
- *Paper Handling Difficulties* on page 127
- *Printing Received Faxes* on page 128

Telephone and Fax problems:

- *Telephone Line or Connections* on page 128
- *Handling Incoming Calls* on page 131
- *Receiving Faxes* on page 129
- *Sending Faxes* on page 130

Copying problems:

- *Copying Difficulties* on page 132

Scanning problems:

- *Scanning Difficulties* on page 132
- *PhotoCapture Center™ Difficulties* on page 132

Software and Network problems:

- *Software Difficulties* on page 133
- *Network Difficulties* on page 133
- *Difficulties when entering data* on page 134

Error and maintenance messages

As with any sophisticated office product, errors may occur and consumable items may need to be replaced. If this happens, your machine identifies the error or required routine maintenance and shows the appropriate message. The most common error and maintenance messages are shown in the table.

You can clear most errors and perform routine maintenance by yourself. If you need additional help, the Brother Solutions Center offers the latest FAQs and troubleshooting tips:

Visit us at <http://solutions.brother.com/>.

Error Message	Cause	Action
B&W 1-sided Print Only Replace ink.	<p>One or more of the colour ink cartridges have reached the end of their life.</p> <p>You can use the machine in monochrome mode for approximately four weeks depending on the number of pages you print.</p> <p>While this message appears on the Touchscreen, each operation works in the following way:</p> <ul style="list-style-type: none"> ■ Printing If you choose Greyscale in the Advanced tab of the printer driver, you can use the machine as a monochrome printer. 2-sided printing is not available when this message appears. ■ Copying If the paper type is set to Plain Paper you can make copies in monochrome. 2-sided copying is not available when this message appears. ■ Faxing If the paper type is set to Plain Paper or Inkjet Paper, the machine will receive and print the faxes in monochrome. If a sending machine has a colour fax, the machine's "handshake" will ask that the fax be sent as monochrome. 	<p>Replace the ink cartridges. (See <i>Replacing the ink cartridges</i> on page 94.)</p> <p>NOTE</p> <p>The machine will stop all print operations, you cannot use the machine until a new ink cartridge is installed in the following cases:</p> <ul style="list-style-type: none"> • If you unplug the machine or take out the ink cartridge. • If the paper type is set to anything except Plain Paper or Inkjet Paper. • (Windows®) If you select Slow Drying Paper in the Basic tab of the printer driver. (Macintosh) If you select Slow Drying Paper in the Print Settings of the printer driver.

Error Message	Cause	Action
BT Call Sign On (U.K. only)	BT Call Sign is set to ON. You cannot change the Receive Mode from Manual to another mode.	Set BT Call Sign to OFF. (See Advanced User's Guide: <i>BT Call Sign (U.K. only)</i> .)
Cannot Detect	You installed a new ink cartridge too quickly and the machine did not detect it.	Take out the new ink cartridge and re-install it slowly and firmly until the cartridge lever lifts. (See <i>Replacing the ink cartridges</i> on page 94.)
	An ink cartridge is not installed correctly.	
	If you are using non Brother Original ink, the machine may not detect the ink cartridge.	Replace the cartridge with a Brother Original ink cartridge. If the error message remains, contact Brother customer service or your local Brother dealer.
Cannot Detect Ink Volume	If you are using non Brother Original ink, the machine may not detect the ink volume.	Replace the cartridge with a Brother Original ink cartridge. If the error message remains, contact Brother customer service or your local Brother dealer.
Cannot Print Replace ink.	One or more of the ink cartridges have reached the end of their life. The machine will stop all print operations. While memory is available, monochrome faxes will be stored in the memory. If a sending machine has a colour fax, the machine's "handshake" will ask that the fax be sent as monochrome.	Replace the ink cartridges. (See <i>Replacing the ink cartridges</i> on page 94.)
Comm. Error	Poor telephone line quality caused a communication error.	If the problem continues, call the telephone company and ask them to check your telephone line.
Connection Failed	You tried to poll a fax machine that is not in Polled Waiting mode.	Check the other fax machine's polling setup.
Cover is Open.	The scanner cover is not locked in the closed position.	Lift the scanner cover, and then close it again.
		Make sure the telephone line cord and USB cable (if used) have been guided correctly through the cable channel and out the back of the machine.
	The ink cartridge cover is not locked in the closed position.	Firmly close the ink cartridge cover until it locks into place.
Data Remaining in Memory	Print data is left in the machine's memory.	Press  . The machine will cancel the job and clear it from the memory. Try to print again.

Error Message	Cause	Action
Disconnected	The other person or other person's fax machine stopped the call.	Try to send or receive again. If calls are stopped repeatedly and you are using a VoIP (Voice over IP) system, try changing the Compatibility to Basic (for VoIP). (See <i>Telephone line interference / VoIP</i> on page 135.)
Document Jam/too Long	The document was not inserted or fed correctly, or the document scanned from the ADF was too long.	(See <i>Using the ADF</i> on page 44.) (See <i>Document jam</i> on page 115.)
High Temperature	The room temperature is too high.	After lowering the room temperature, allow the machine to cool down to room temperature. Try again later.
Hub is Unusable.	A hub or USB Flash drive with hub has been connected to the USB direct interface.	Hubs, including USB Flash drives with built-in hubs, are not supported. Unplug the device from the USB direct interface.
Image Too Long	The proportions of your photo are irregular so effects could not be added.	Choose a regularly proportioned image.
Image Too Small	The size of your photo is too small to trim.	Choose a larger image.

Error Message	Cause	Action
Ink Absorber Full	<p>The ink absorber box or flushing box is full. These components are periodic maintenance items that may require replacement after a period of time to ensure optimum performance from your Brother machine. Because these components are periodic maintenance items, the replacement is not covered under the warranty. The need to replace these items and the time period before replacement is dependent on the number of purges and flushes required to clean the ink system. These boxes acquire amounts of ink during the different purging and flushing operations. The number of times a machine purges and flushes for cleaning varies depending on different situations. For example, frequently powering the machine on and off will cause numerous cleaning cycles since the machine automatically cleans itself upon power up. The use of non-Brother ink may cause frequent cleanings because non-Brother ink could cause poor print quality, which is resolved by cleaning. The more cleaning the machine requires, the faster these boxes will fill up.</p> <p>NOTE</p> <p><i>Repairs resulting from the use of non-Brother supplies may not be covered under the stated product warranty.</i></p>	<p>The ink absorber box or flushing box will need to be replaced. Contact Brother Customer Service or your local Brother Authorised Service Centre to have your machine serviced.</p> <p>Other reasons for cleaning are:</p> <ol style="list-style-type: none"> 1 After a paper jam has been cleared, the machine automatically cleans itself before the next received fax is printed. 2 The machine automatically cleans itself after sitting idle for more than 30 days (infrequent use). 3 The machine automatically cleans itself after ink cartridges of the same colour have been replaced 12 times.
Ink Absorber NearFull	The ink absorber box or flushing box is nearly full.	Contact Brother customer service or your local Brother dealer.
Ink Low	One or more of the ink cartridges are near the end of their life. If one of the colour ink cartridges is near the end of its life and someone is sending you a colour fax, your machine's "handshake" will ask that the fax be sent as monochrome. If the sending machine has the ability to convert it, the colour fax will be printed at your machine as a monochrome fax.	Order a new ink cartridge. You can continue printing until the Touchscreen shows <i>Cannot Print</i> . (See <i>Replacing the ink cartridges</i> on page 94.)





Error Message	Cause	Action
Low Temperature	The room temperature is too low.	After increasing the room temperature, allow the machine to warm up to room temperature. Try again later.
Media Error	The memory card is either corrupted, incorrectly formatted, or there is a problem with the memory card.	Remove the memory card from the media drive (slot) of the machine and format it correctly.
		Put the card firmly into the slot again to make sure it is in the correct position. If the error remains, check the media drive (slot) of the machine by inserting a working memory card.
Media is Full.	The memory card or USB Flash drive you are using already contains 999 files.	Your machine can only save to your memory card or USB Flash drive if it contains less than 999 files. Delete unused files and try again.
	The memory card or USB Flash drive you are using does not have enough free space to scan the documents.	Press  . Delete unused files from your memory card or USB Flash drive to make some free space, and then try again.
No Caller ID	There is no incoming call history. You did not receive calls or you have not subscribed to the Caller ID service from your telephone company.	If you want to use the Caller ID feature, call your telephone company. (See <i>Caller ID (U.K. and Ireland only)</i> on page 63.)
No File	The memory card or USB Flash drive in the media drive does not contain a .JPG file.	Insert a different memory card or USB Flash drive containing .JPG files into the slot.
No Ink Cartridge	An ink cartridge is not installed correctly.	Take out the new ink cartridge and re-install it slowly and firmly until the cartridge lever lifts. (See <i>Replacing the ink cartridges</i> on page 94.)

Error Message	Cause	Action
(MFC-J6520DW) No Paper Fed (MFC-J6720DW) No Paper Fed No Paper Fed #1 No Paper Fed #2	The machine is out of paper, or paper is not correctly loaded in the paper tray. The paper tray was not fully inserted. The paper was not inserted in the centre position of the manual feed slot. The Jam Clear Cover is not closed correctly. Paper dust has accumulated on the surface of the paper pick-up rollers. The paper is jammed in the machine.	Do one of the following: <ul style="list-style-type: none"> ■ Refill the paper in the paper tray, and then press OK on the Touchscreen. ■ Remove and reload the paper, then press OK on the Touchscreen. (See <i>Loading paper and other print media</i> on page 20.) Remove the paper tray and re-install it until it locks into place, and then press OK on the Touchscreen. Remove the paper and re-insert it in the centre of the manual feed slot, and then press OK on the Touchscreen. (See <i>Loading paper in the manual feed slot</i> on page 33.) Make sure the Jam Clear Cover is closed evenly at both ends. (See <i>Printer jam or paper jam</i> on page 117.) Clean the paper pick-up rollers. (See <i>Advanced User's Guide: Cleaning the paper pick-up rollers.</i>) Remove the jammed paper by following the steps in <i>Printer jam or paper jam</i> on page 117. If this error occurs often during 2-sided copying or 2-sided printing, the paper feed rollers may be stained with ink. Clean the paper feed rollers. (See <i>Advanced User's Guide: Cleaning the paper feed rollers.</i>)
No Response/Busy	The number you dialled has not answered or is busy.	Verify the number and try again.
Out of Fax Memory	The fax memory is full.	Do one of the following: <ul style="list-style-type: none"> ■ Clear the data from the memory. To gain extra memory, you can turn off Memory Receive. (See <i>Advanced User's Guide: Turning off Memory Receive operations.</i>) ■ Print the faxes that are in the memory. (See <i>Advanced User's Guide: Printing a fax from the memory.</i>)

Error Message	Cause	Action
Out of Memory	The machine's memory is full.	<p>If a fax-sending or copy operation is in process:</p> <ul style="list-style-type: none"> ■ Press , Quit or Close and wait until the other operations that are in process finish, and then try again. ■ Press Send Now to send the pages scanned so far. ■ Press Partial Print to copy the pages scanned so far. ■ Clear the data in the memory. To gain extra memory, you can turn off Memory Receive. (See Advanced User's Guide: <i>Turning off Memory Receive operations</i>.) ■ Print the faxes that are in the memory. (See Advanced User's Guide: <i>Printing a fax from the memory</i>.)
Paper Jam [Front]	The paper is jammed in the machine.	<p>Remove the jammed paper by following the steps in <i>Printer jam or paper jam</i> on page 117.</p> <p>Make sure the paper length guide is set to the correct paper size. DO NOT extend the paper tray when you load A5 or smaller size paper.</p> <p>If there is a repeat paper jam, a small piece of paper may be stuck in the machine. Make sure paper is not still jammed in the machine. (See <i>Additional paper jam clear operations</i> on page 121.)</p>

Error Message	Cause	Action
<p>Paper Jam [Front,Rear]</p>	<p>The paper is jammed in the machine.</p>	<p>Remove the jammed paper by following the steps in <i>Printer jam or paper jam</i> on page 117.</p> <p>Make sure the paper length guide is set to the correct paper size. DO NOT extend the paper tray when you load A5 or smaller size paper.</p> <p>If there is a repeat paper jam, a small piece of paper may be stuck in the machine. Make sure paper is not still jammed in the machine. (See <i>Additional paper jam clear operations</i> on page 121.)</p>
	<p>More than one sheet of paper was placed in the manual feed slot.</p> <p>—OR—</p> <p>Another sheet of paper was placed in the manual feed slot before the Touchscreen showed</p> <p>Put paper in Manual Feed Slot, and then Press [OK].</p>	<p>Do not put more than one sheet of paper in the manual feed slot at any one time. Wait until the Touchscreen shows</p> <p>Put paper in Manual Feed Slot, and then Press [OK]. before you feed the next sheet of paper in the manual feed slot.</p> <p>Remove the jammed paper by following the steps in <i>Printer jam or paper jam</i> on page 117.</p>
<p>Paper Jam [Rear]</p>	<p>The paper is jammed in the machine.</p>	<p>Remove the jammed paper by following the steps in <i>Printer jam or paper jam</i> on page 117.</p> <p>Make sure the paper length guide is set to the correct paper size. DO NOT extend the paper tray when you load A5 or smaller size paper.</p> <p>If there is a repeat paper jam, a small piece of paper may be stuck in the machine. Make sure paper is not still jammed in the machine. (See <i>Additional paper jam clear operations</i> on page 121.)</p>
	<p>Paper dust has accumulated on the surface of the paper pick-up rollers.</p>	<p>Clean the paper pick-up rollers. (See <i>Advanced User's Guide: Cleaning the paper pick-up rollers.</i>)</p>
<p>Touchscreen Init. Failed</p>	<p>The Touchscreen was pressed before the power on initialization was completed.</p>	<p>Make sure that nothing is touching or resting on the Touchscreen, especially when plugging the machine in.</p>
	<p>Debris may be stuck between the lower part of the Touchscreen and its frame.</p>	<p>Insert a piece of stiff paper between the lower part of the Touchscreen and its frame and slide it back and forth to push out the debris.</p>



Error Message	Cause	Action
Unable to Clean XX Unable to Initialize XX Unable to Print XX	The machine has a mechanical problem. —OR— A foreign object, such as a paper clip or a piece of ripped paper, is in the machine.	Open the scanner cover and remove any foreign objects and paper scraps from inside the machine. If the error message continues, disconnect the machine from the power for several minutes, and then reconnect it. For more information, see <i>Additional paper jam clear operations</i> on page 121. (The machine can be turned off for approximately 24 hours without losing faxes stored in the memory. See <i>Transferring your faxes or Fax Journal report</i> on page 114.)
Unable to Scan XX	The machine has a mechanical problem.	Disconnect the machine from the power for several minutes, and then reconnect it. The machine can be turned off for approximately 24 hours without losing faxes stored in the memory. (See <i>Transferring your faxes or Fax Journal report</i> on page 114.)
Unusable Device Disconnect device from front connector & turn machine off & then on	A broken device has been connected to the USB direct interface.	Unplug the device from the USB direct interface, then press  to turn the machine off and then on again.
Unusable Device Please disconnect USB device.	A USB device or USB Flash drive that is not supported is connected to the USB direct interface. For more information, visit us at http://solutions.brother.com/ .	Unplug the device from the USB direct interface, then press  to turn the machine off and then on again.
Wrong Ink Colour	An ink cartridge has been installed in the wrong position.	Check which ink cartridges are not matched by colour to their ink cartridge positions and move them to their correct positions.

Error Message	Cause	Action
<p>(MFC-J6520DW) Wrong Paper</p> <p>(MFC-J6720DW) Wrong Paper</p> <p>Wrong Paper #1</p> <p>Wrong Paper #2</p>	<p>The paper size setting does not match the size of paper in the tray.</p> <p>The paper orientation is incorrect for the paper size.</p> <p>You did not set the paper guides in the tray to the indicators for the paper size you are using.</p>	<p>1 Check that the paper size you choose matches the size of paper in the tray. (MFC-J6520DW: See <i>Paper Size (MFC-J6520DW)</i> on page 37.) (MFC-J6720DW: See <i>Paper Size and Type (MFC-J6720DW)</i> on page 37.)</p> <p>2 Make sure you load the paper in a correct position, by setting the paper guides to the indicators for your paper size. (See <i>Loading paper and other print media</i> on page 20.)</p> <p>3 After you have checked the paper size and the paper position, press OK on the Touchscreen.</p> <p>If you are printing from your computer, make sure the paper size you choose in the printer driver matches the size of paper in the tray. (See <i>Software and Network User's Guide</i>.)</p>
<p>Wrong Tray Setting (MFC-J6720DW)</p>	<p>The machine's Paper Size and Tray Use settings do not match the size of paper in the tray you are using.</p>	<p>Follow the instructions on the Touchscreen and try to print again.</p> <p>Configure the paper size setting for the tray according to the on-screen instructions.</p>

Error animations

Error animations display step-by-step instructions when paper gets jammed. You can read the steps at your own pace by pressing **▶** to see the next step and **◀** to go back a step.

Transferring your faxes or Fax Journal report

If the Touchscreen shows:



- Unable to Clean XX
- Unable to Initialize XX
- Unable to Print XX
- Unable to Scan XX

We recommend transferring your faxes to another fax machine or to your PC. (See *Transferring faxes to another fax machine* on page 114 or *Transferring faxes to your PC* on page 114.)

You can also transfer the Fax Journal report to see if there are any faxes you need to transfer. (See *Transferring the Fax Journal report to another fax machine* on page 115.)

Transferring faxes to another fax machine

If you have not set up your Station ID, you cannot enter fax transfer mode. (See Quick Setup Guide: *Enter personal information (Station ID)*.)

- 1 Press  to temporarily interrupt the error.
- 2 Press  (Settings).
- 3 Press All Settings.
- 4 Press **▲** or **▼** to display Service.
- 5 Press Service.
- 6 Press Data Transfer.

- 7 Press Fax Transfer.
- 8 Do one of the following:
 - If the Touchscreen shows No Data, there are no faxes left in the machine's memory.

Press Close, and then press .
 - Enter the fax number to which faxes will be forwarded.
- 9 Press Fax Start.

Transferring faxes to your PC

You can transfer the faxes from your machine's memory to your PC.

- 1 Press  to temporarily interrupt the error.
- 2 Make sure you have installed **MFL-Pro Suite** on your PC, and then turn on **PC-FAX Receiving** on the PC. Do one of the following:

(Windows[®] XP, Windows Vista[®] and Windows[®] 7)

From  (**Start**), select **All Programs**, **Brother, MFC-XXXX**, **PC-FAX Receiving**, and select **Receive**. (where XXXX is your model name.)



(Windows[®] 8)

Click  (**Brother Utilities**), and then click the drop-down list and select your model name (if not already selected). Click **PC-FAX Receive** in the left navigation bar, and then click **Receive**.

- 3 Make sure you have set PC-Fax Receive on the machine. (See *PC-FAX Receiving (Windows®)* on page 61.) If faxes are in the machine's memory when you set up PC-Fax Receive, the Touchscreen will ask if you want to transfer the faxes to your PC.
- 4 Do one of the following:
 - To transfer all faxes to your PC, press **Yes**. If Fax Preview is set to **Off**, you will be asked if you want to also turn on the backup print option.
 - To exit and leave the faxes in the memory, press **No**.
- 5 Press .

Transferring the Fax Journal report to another fax machine

If you have not set up your Station ID, you cannot enter fax transfer mode. (See Quick Setup Guide: *Enter personal information (Station ID)*.)

- 1 Press  to temporarily interrupt the error.
- 2 Press  (Settings).
- 3 Press **All Settings**.
- 4 Press **▲** or **▼** to display **Service**.
- 5 Press **Service**.
- 6 Press **Data Transfer**.
- 7 Press **Report Transfer**.
- 8 Enter the fax number to which the Fax Journal report will be forwarded.
- 9 Press **Fax Start**.

Document jam

Documents can jam in the ADF unit if they are not inserted or fed correctly, or if they are too long. Follow the steps to clear a document jam.

Document is jammed in the top of the ADF unit

- 1 Take out any paper from the ADF that is not jammed.
- 2 Open the ADF cover.
- 3 Remove the jammed document by pulling it upward.

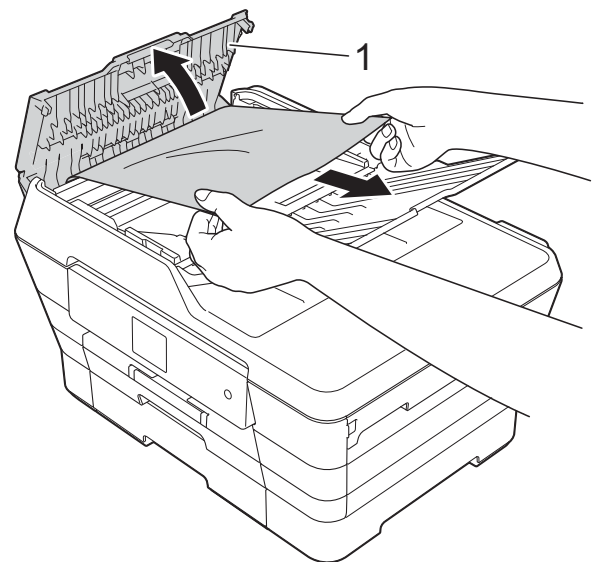

1 ADF cover

- 4 Close the ADF cover.
- 5 Press .

IMPORTANT

To avoid document jams, close the ADF cover correctly by pushing it gently in the centre.

Document is jammed inside the ADF unit

- 1 Take any paper that is not jammed out of the ADF.
- 2 Lift the document cover.
- 3 Pull the jammed document out to the left.

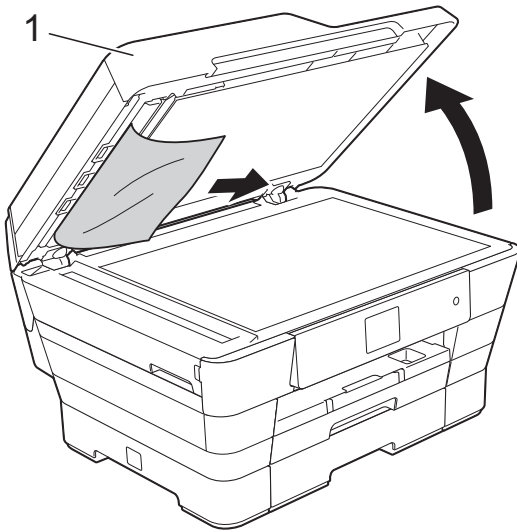

1 document cover

- 4 Close the document cover.
- 5 Press .

Removing small documents jammed in the ADF

- 1 Lift the document cover.
- 2 Insert a piece of stiff paper, such as cardstock, into the ADF to push any small paper scraps through.

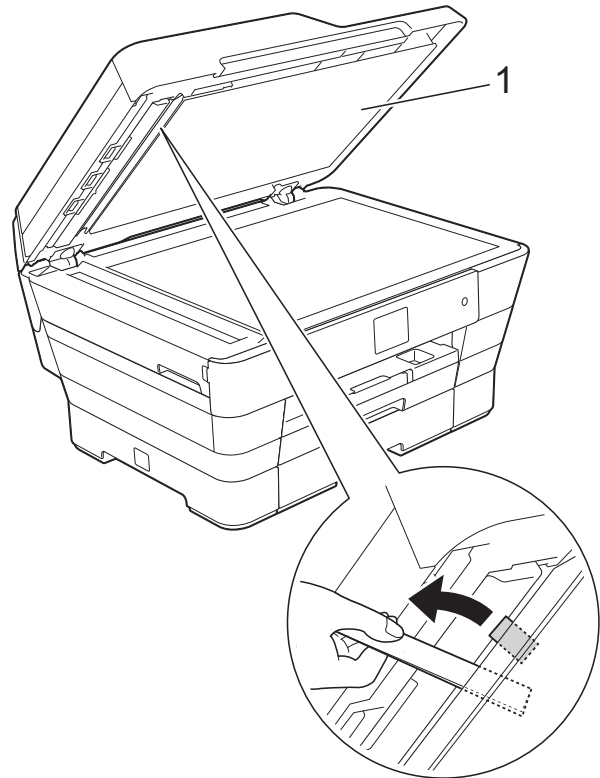

1 document cover

- 3 Close the document cover.
- 4 Press .

Printer jam or paper jam

Located and removed the jammed paper by following these steps.

- 1 Unplug the machine from the electrical socket.
- 2 (MFC-J6520DW)
Pull the paper tray #1 (1) completely out of the machine.

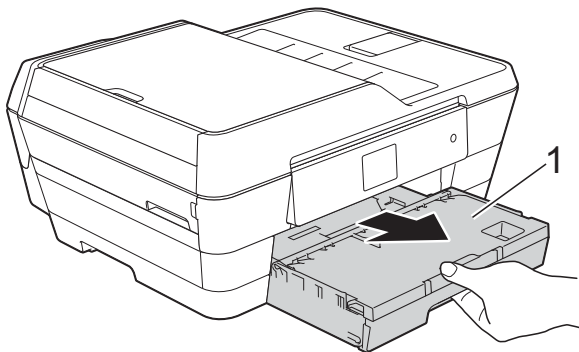

- (MFC-J6720DW)
Pull paper tray #1 and then tray #2 (2) completely out of the machine.

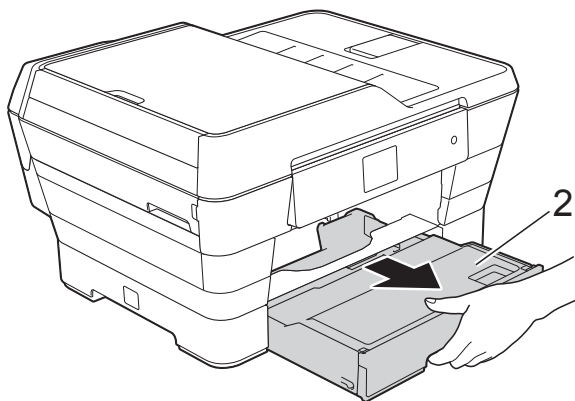

- If the Touchscreen shows Paper Jam [Rear], go to step 10.

- 3 Pull out the jammed paper (1).
(MFC-J6520DW)

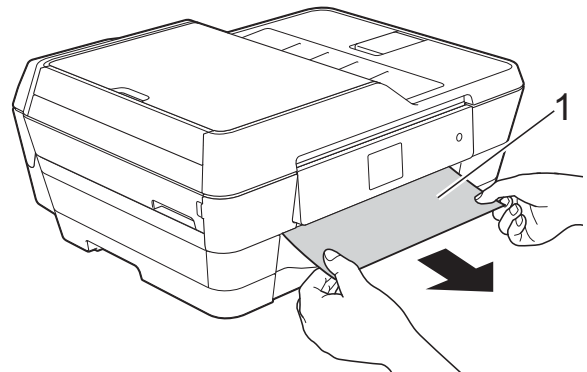

(MFC-J6720DW)

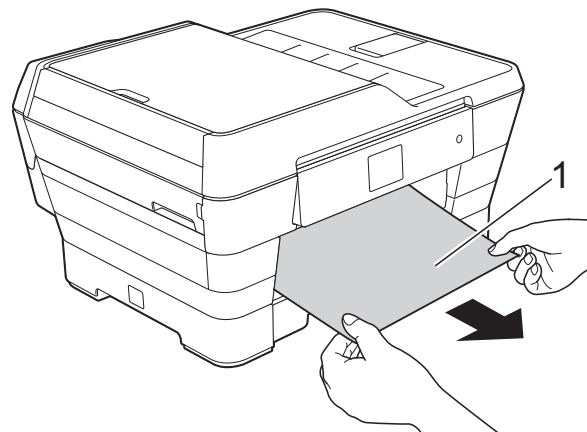

- 4 Lift the green Jam Clear Flap, and remove the jammed paper.

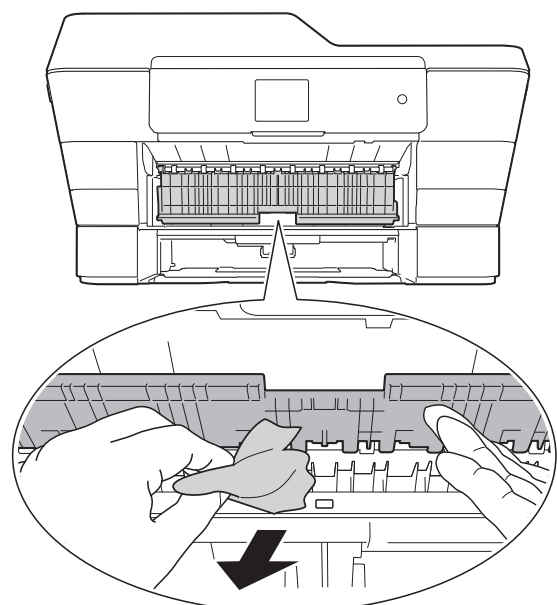

- 5 Make sure you look carefully inside the machine above and below the green Jam Clear Flap for any pieces of paper.

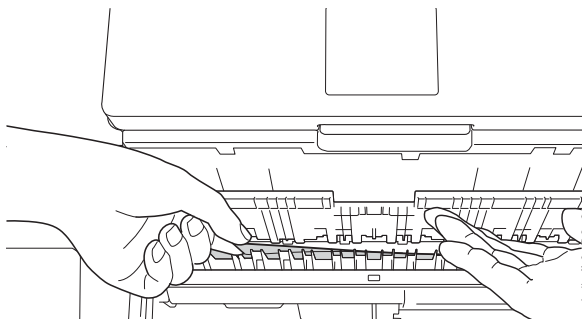

- 6 Using both hands, use the finger holds on each side of the machine to lift the scanner cover (1) into the open position.

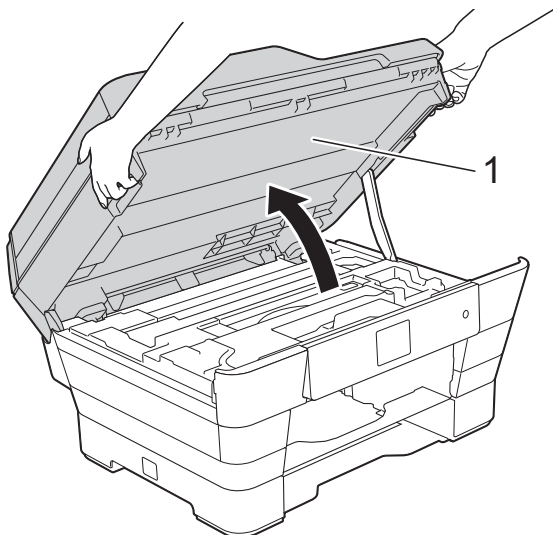

- 7 Slowly pull the jammed paper (1) out of the machine.

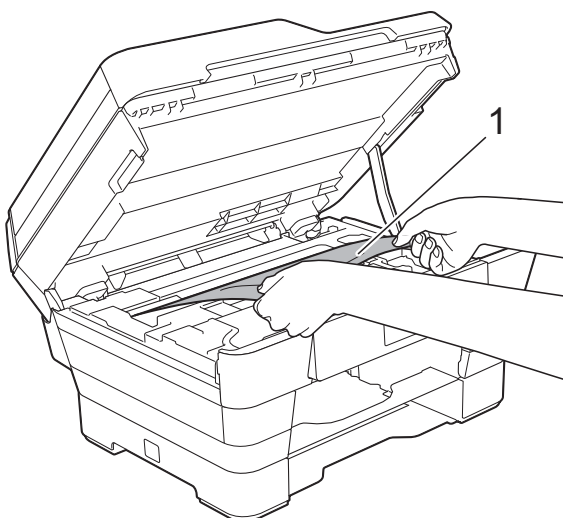

- 8 Move the print head (if necessary) to reach any paper remaining in this area. Make sure no jammed paper is left in the corners of the machine (1) and (2).

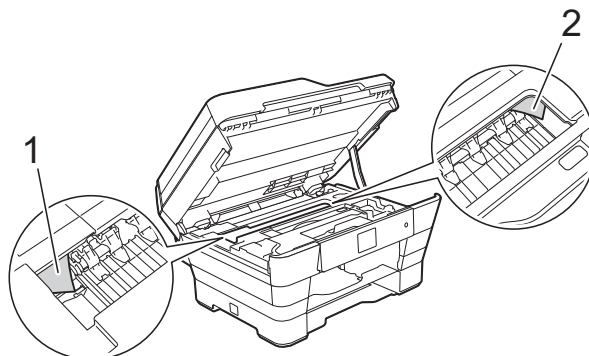

IMPORTANT

- If the paper is jammed under the print head, unplug the machine from the power source, and then move the print head to reach the paper.
- If the print head is in the right corner as shown in the illustration, you cannot move the print head. Re-connect the power cord. Hold down  until the print head moves to the centre. Then unplug the machine from the power source and remove the paper.

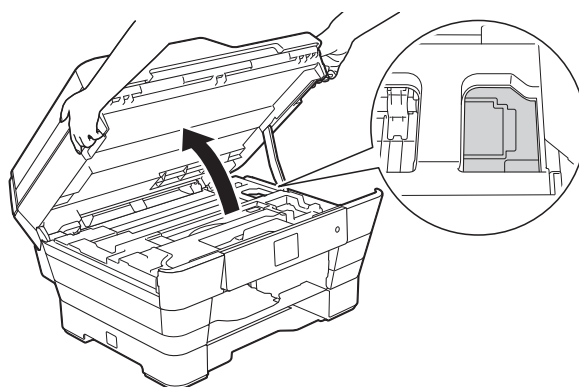

- If ink gets onto your skin, immediately wash with soap and plenty of water.

- 9 Make sure you look carefully inside (1) for any pieces of paper.

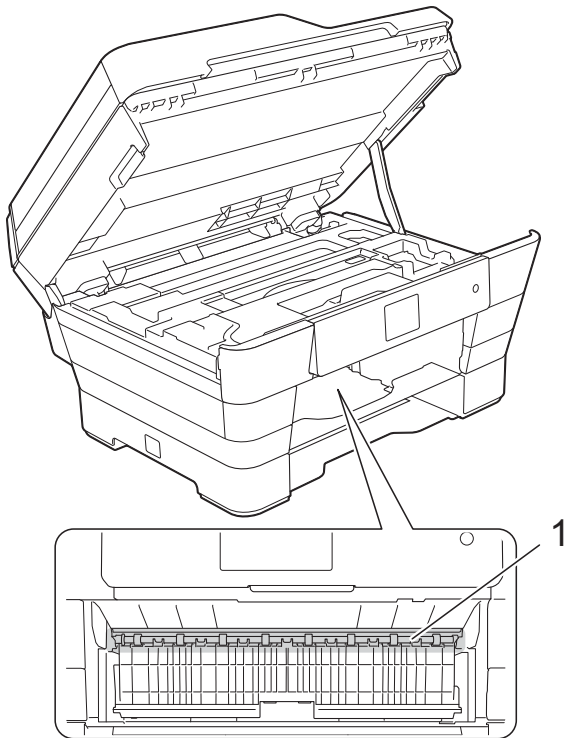

- 10 Open the Jam Clear Cover at the back of the machine.

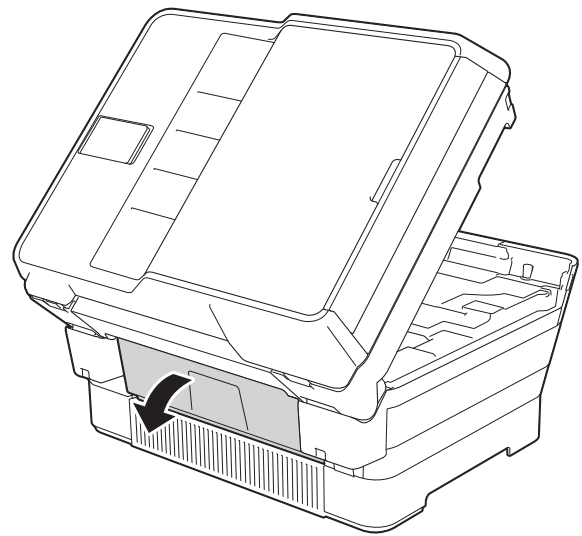

- 11 Open the inside cover (1).

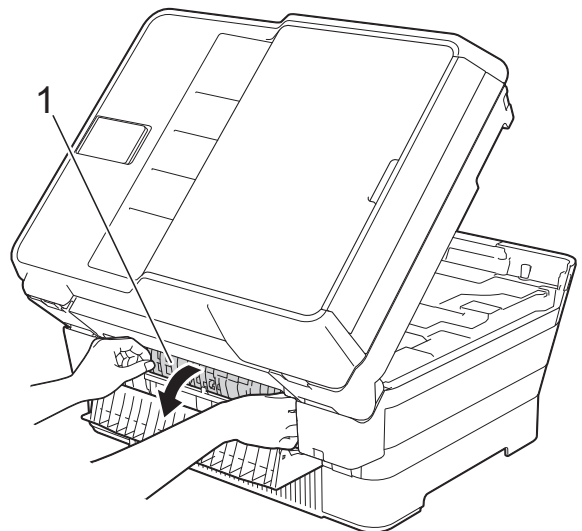

Do one of the following:

- If the Touchscreen shows Paper Jam [Front], go to step 14.
- If the Touchscreen shows Paper Jam [Front, Rear], go to step 10.

- 12** Make sure you look carefully inside for any jammed paper. If there is any jammed paper, slowly pull it out of the machine.

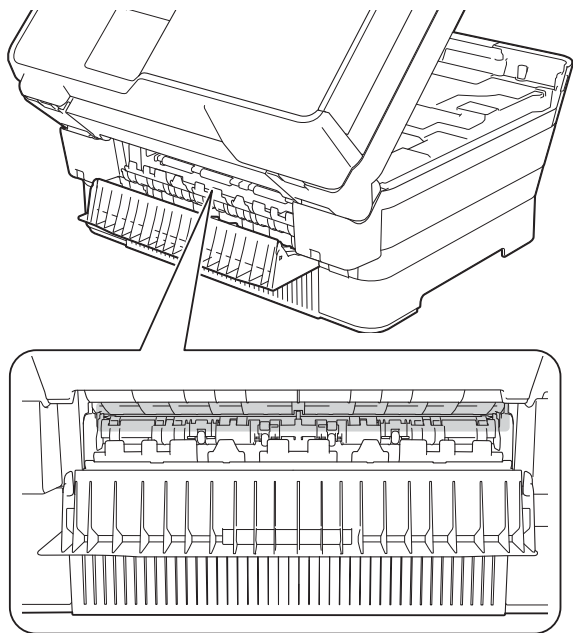

- 13** Close the inside cover and Jam Clear Cover. Make sure the covers are closed completely.

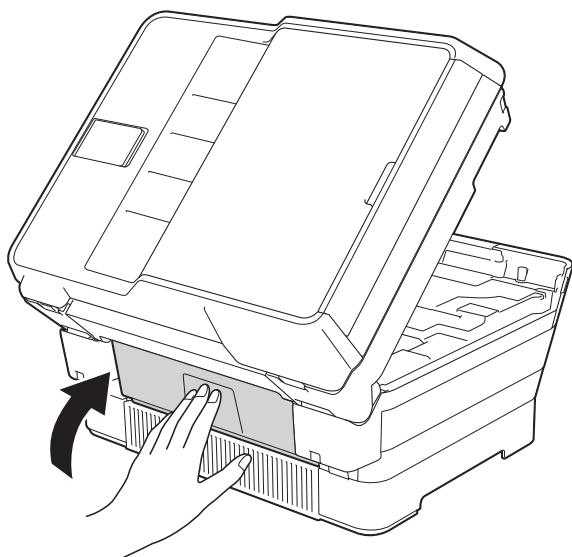

- 14** Put the paper tray firmly back in the machine.
(MFC-J6520DW)

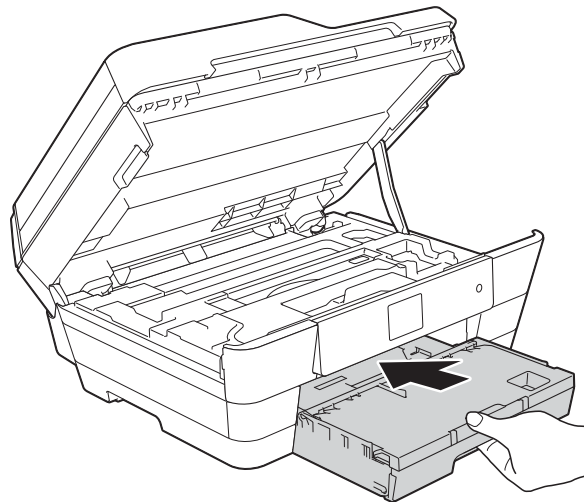

(MFC-J6720DW)

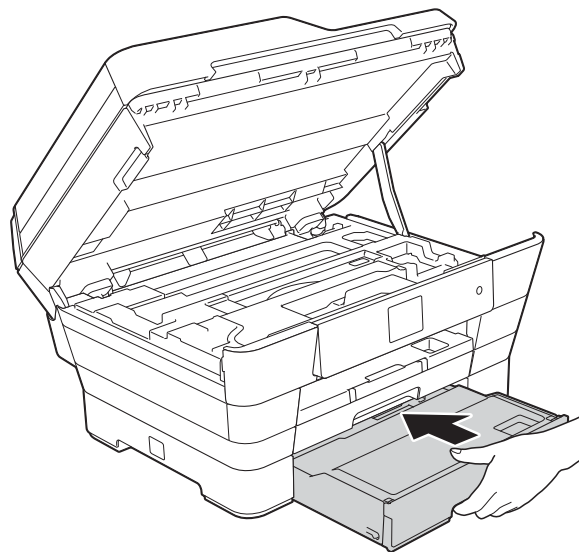

- 15 Gently close the scanner cover using the finger holds on each side.

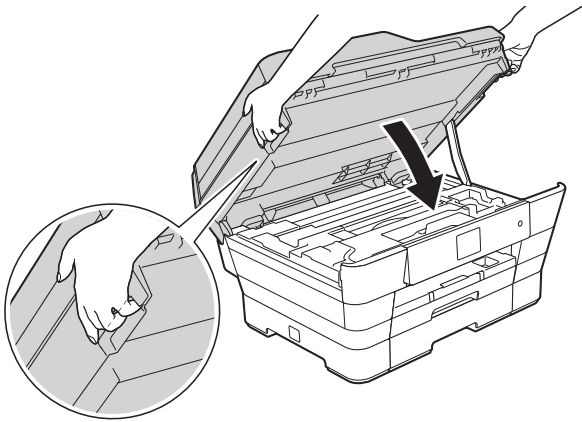

⚠ CAUTION

Be careful not to pinch your fingers when you close the scanner cover. Always use the finger holds provided on each side of the scanner cover when opening and closing it.

NOTE

Make sure you pull out the paper support until it clicks.

- 16 Re-connect the power cord.

NOTE

If there is a repeat paper jam, a small piece of paper may be stuck in the machine. (See *Additional paper jam clear operations* on page 121.)

Additional paper jam clear operations

- 1 Using both hands, use the finger holds on each side of the machine to lift the scanner cover (1) into the open position. Move the print head (if necessary) to reach any paper remaining in this area. Make sure no jammed paper is left in the corners of the machine (2) and (3).

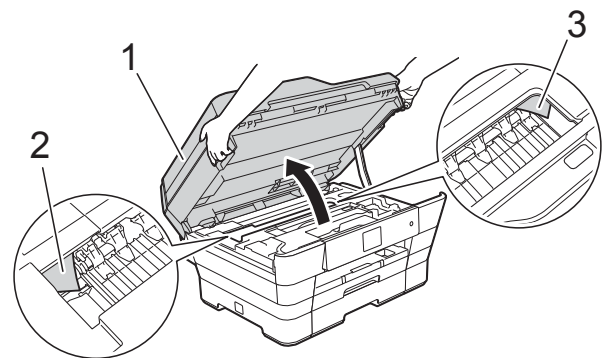

NOTE

If the print head is at the right corner as shown in the illustration, hold down  until the print head moves to the centre.

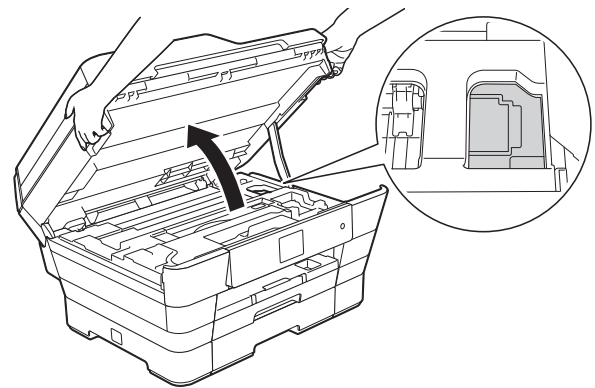

- 2 Unplug the machine from the electrical socket.

- 3 Gently close the scanner cover using the finger holds on each side.

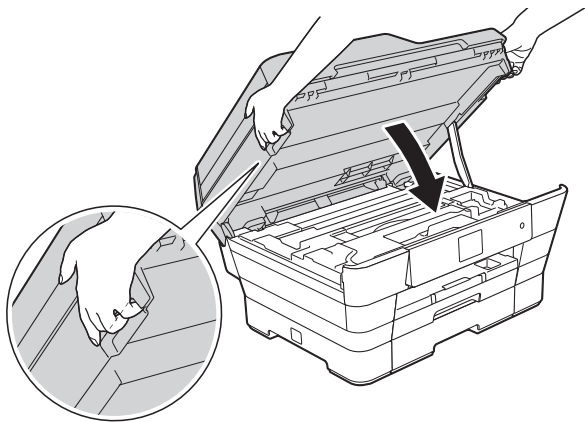

⚠ CAUTION

Be careful not to pinch your fingers when you close the scanner cover. Always use the finger holds provided on each side of the scanner cover when opening and closing it.

- 4 Open the manual feed slot cover.

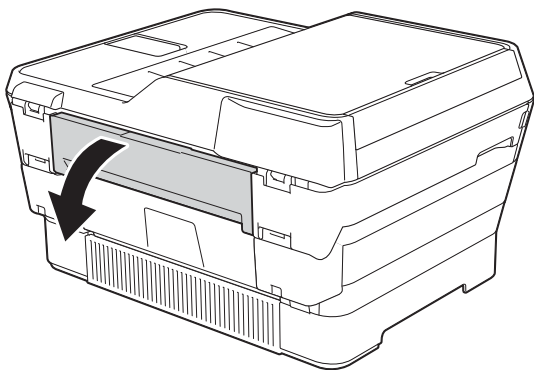

- 5 Put only one sheet of A4 or Letter size thick paper, such as glossy paper, in Landscape orientation in the manual feed slot. Push the paper into the manual feed slot.

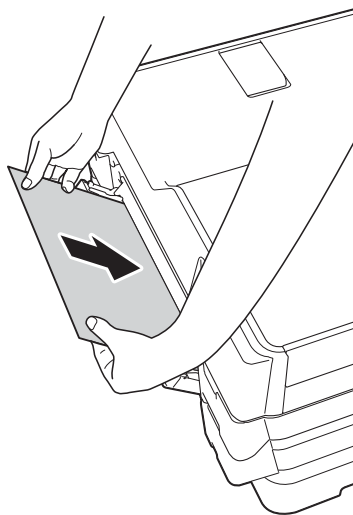

NOTE

- We recommend you use glossy paper.
- If you don't push the paper far enough into the manual feed slot, the machine will not feed it when you re-connect the power cord.

- 6 Re-connect the power cord. The paper you placed in the manual feed slot will be fed through the machine and ejected.
- 7 Using both hands, use the finger holds on each side of the machine to lift the scanner cover into the open position. Make sure that a piece of paper is not still jammed inside the machine. Gently close the scanner cover using the finger holds on each side.



If you are having difficulty with your machine

NOTE

- For technical help, you must contact Brother customer support.
- If you think there is a problem with your machine, check the following chart and follow the troubleshooting tips. You can correct most problems by yourself.
- If you need additional help, the Brother Solutions Center offers the latest FAQs and troubleshooting tips.



Visit us at <http://solutions.brother.com/>.

Printing Difficulties





Difficulty	Suggestions
No printout.	Check that the correct printer driver has been installed and chosen.
	Check to see if the Touchscreen is showing an error message. (See <i>Error and maintenance messages</i> on page 104.)
	<p>Make sure that the machine is online.</p> <p>(Windows® XP and Windows Server® 2003) Click Start/Printers and Faxes. Right-click Brother MFC-XXXX Printer (where XXXX is your model name). If the printer is offline, it will show Use Printer Online. Select this option to enable the printer.</p> <p>(Windows Vista® and Windows Server® 2008) Click  Control Panel/Hardware and Sound/Printers. Right-click Brother MFC-XXXX Printer (where XXXX is your model name). If the printer is offline, it will show Use Printer Online. Select this option to enable the printer.</p> <p>(Windows® 7 and Windows Server® 2008 R2) Click  Devices and Printers. Right-click Brother MFC-XXXX Printer (where XXXX is your model name) and choose See what's printing. Click Printer and make sure that Use Printer Offline is cleared.</p> <p>(Windows® 8 and Windows Server® 2012) Move your mouse to the lower right corner of your desktop. When the menu bar appears, click Settings, and then click Control Panel. In the Hardware and Sound (Hardware) group, click View devices and printers. Right-click Brother MFC-XXXX Printer (where XXXX is your model name) and select See what's printing. If printer driver options appear, select your printer driver. Click Printer in the menu bar and make sure that Use Printer Offline is not selected.</p>
	One or more ink cartridges have reached the end of their life. (See <i>Replacing the ink cartridges</i> on page 94.)





Printing Difficulties (continued)

Difficulty	Suggestions
<p>No printout. (continued)</p>	<p>The document will not print if the old, unprinted data remains in the printer driver spooler. Open the printer icon, and then delete all the data. Your printer icon can be found in the following way:</p> <p>(Windows® XP and Windows Server® 2003) Click Start/Printers and Faxes.</p> <p>(Windows Vista® and Windows Server® 2008) Click /Control Panel/Hardware and Sound/Printers.</p> <p>(Windows® 7 and Windows Server® 2008 R2) Click /Devices and Printers/Printers and Faxes.</p> <p>(Windows® 8 and Windows Server® 2012) Move your mouse to the lower right corner of your desktop. When the menu bar appears, click Settings/Control Panel/Hardware and Sound (Hardware) group/View devices and printers/Printers.</p> <p>(Mac OS X v10.6.8) Click System Preferences/Print & Fax.</p> <p>(OS X v10.7.x, 10.8.x) Click System Preferences/Print & Scan.</p>
<p>The headers or footers appear when the document displays on the screen but they do not show up when it is printed.</p>	<p>There is an unprintable area on the top and bottom of the page. Adjust the top and bottom margins in your document to allow for this.</p> <p>(See <i>Unprintable area</i> on page 36.)</p>
<p>Cannot perform “Page Layout” printing.</p>	<p>Check that the paper size setting in the application and in the printer driver are the same.</p>
<p>Print speed is too slow.</p>	<p>Try changing the printer driver setting. The highest resolution needs longer data processing, sending and printing time. Try the other quality settings in the printer driver as follows:</p> <p>(Windows®) Click Colour Settings on the Advanced tab, and make sure you clear Colour Enhancement.</p> <p>(Macintosh) Choose Color Settings, click Advanced Color Settings, and make sure you clear Color Enhancement.</p> <p>Turn the Borderless feature off. Borderless printing is slower than normal printing. (See Software and Network User’s Guide.)</p>
<p>Colour Enhancement is not working correctly.</p>	<p>If the image data is not full colour in your application (such as 256 colour), Colour Enhancement will not work. Use at least 24 bit colour data with the Colour Enhancement feature.</p>
<p>Machine does not print from Adobe® Illustrator®.</p>	<p>Try to reduce the print resolution. (See Software and Network User’s Guide.)</p>

Print Quality Difficulties

Difficulty	Suggestions
<p>Poor print quality.</p>	<p>Check the print quality. (See <i>Checking the print quality</i> on page 98.)</p> <p>Make sure that the Media Type setting in the printer driver or the <i>Paper Type</i> setting in the machine's menu matches the type of paper you are using. (See <i>Paper Type (MFC-J6520DW)</i> on page 37.) (See <i>Software and Network User's Guide</i>.)</p> <p>Make sure that your ink cartridges are fresh. The following may cause ink to clog:</p> <ul style="list-style-type: none"> ■ The expiration date written on the cartridge package has passed. (Brother Original cartridges stay usable for up to two years if kept in their original packaging.) ■ The ink cartridge has been in your machine for over six months. ■ The ink cartridge may not have been stored correctly before use. <p>Make sure you are using Brother Original Innobella™ ink. Brother does not recommend the use of cartridges other than Brother Original cartridges or the refilling of used cartridges with ink from other sources.</p> <p>Make sure you are using one of the recommended types of paper. (See <i>Acceptable paper and other print media</i> on page 39.)</p> <p>The recommended environment for your machine is between 20 °C to 33 °C.</p>
<p>White horizontal lines appear in text or graphics.</p>  <p>A4, Letter and Executive</p>  <p>A3, Ledger, Legal, Folio, A5, A6, Envelopes, Photo (10 × 15 cm), Photo L (89 × 127 mm), Photo 2L (13 × 18 cm) and Index Card (127 × 203 mm)</p>	<p>Clean the print head. (See <i>Cleaning the print head</i> on page 98.)</p> <p>Make sure you are using Brother Original Innobella™ ink.</p> <p>Try using the recommended types of paper. (See <i>Acceptable paper and other print media</i> on page 39.)</p> <p>To prolong print head life, provide the best ink cartridge economy and maintain print quality, we do not recommend frequently unplugging the machine and/or leaving the machine unplugged for extended periods of time. We recommend using  to power down the machine. Using  allows minimal power to the machine ensuring periodic cleanings of the print head occur.</p>

Print Quality Difficulties (continued)

Difficulty	Suggestions
The machine prints blank pages.	Clean the print head. (See <i>Cleaning the print head</i> on page 98.)
	Make sure you are using Brother Original Innobella™ ink.
	To prolong print head life, provide the best ink cartridge economy and maintain print quality, we do not recommend frequently unplugging the machine and/or leaving the machine unplugged for extended periods of time. We recommend using  to power down the machine. Using  allows minimal power to the machine ensuring periodic cleanings of the print head occur.
Characters and lines are blurred.	Check the printing alignment. (See <i>Checking the print alignment</i> on page 100.)
Printed text or images are skewed.	Make sure the paper is loaded correctly in the paper tray and the paper guides are adjusted correctly. (See <i>Loading paper and other print media</i> on page 20.)
	Make sure the Jam Clear Cover is closed correctly.
Smudge or stain at the top centre of the printed page.	Make sure the paper is not too thick or curled. (See <i>Acceptable paper and other print media</i> on page 39.)
Printing appears dirty or ink seems to run.	Make sure you are using the recommended types of paper. (See <i>Acceptable paper and other print media</i> on page 39.) Don't handle the paper until the ink is dry.
	Make sure the print side is face down in the paper tray.
	Make sure you are using Brother Original Innobella™ ink.
	If you are using photo paper, make sure that you have set the correct paper type. If you are printing a photo from your PC, set the Media Type in the printer driver.
Ink is smudged or wet when using glossy photo paper.	Be sure to check the front and back of the paper. Place the glossy surface (printing surface) face down. (See <i>Paper Type (MFC-J6520DW)</i> on page 37.)
	If you use glossy photo paper, make sure that the paper type setting is correct.
Printouts appear dirty or the paper jams when using A3 paper.	(PC print for Windows®)
	Select Slow Drying Paper in the Basic tab of the printer driver.
	(PC print for Macintosh)
	Select Print Settings from the drop-down list and then check Slow Drying Paper of the printer driver.
Stains appear on the reverse side or at the bottom of the page.	(Copy)
	Adjust the copy density to make copies lighter. (See <i>Advanced User's Guide: Adjusting Density</i> .)
	Make sure the printer platen is not dirty with ink. (See <i>Advanced User's Guide: Cleaning the machine's printer platen</i> .)
The machine prints dense lines on the page.	Make sure you are using Brother Original Innobella™ ink.
	Make sure you are using the paper support flap. (See <i>Loading paper and other print media</i> on page 20.)
	Make sure the paper feed rollers are not dirty with ink. (See <i>Advanced User's Guide: Cleaning the paper feed rollers</i> .)
	(Windows®)
	Select Reverse Order in the Basic tab of the printer driver.

Print Quality Difficulties (continued)

Difficulty	Suggestions
The printouts are wrinkled.	(Windows®) In the printer driver Advanced tab, click Colour Settings and clear Bi-Directional Printing .
	(Macintosh) In the printer driver, choose Print Settings , click Advanced , choose Other Print Options and clear Bi-Directional Printing .
	Make sure you are using Brother Original Innobella™ ink.

Paper Handling Difficulties

Difficulties	Suggestions
The machine does not feed paper.	Make sure the paper tray is pushed in all the way until it clicks into place.
	Make sure the Jam Clear Cover at the back of the machine is closed.
	If the Touchscreen shows the Paper Jam message and you still have a problem, see <i>Error and maintenance messages</i> on page 104.
	If there is no paper, load a new stack of paper into the paper tray.
	If there is paper in the paper tray, make sure it is straight. If the paper is curled, straighten it. Sometimes it is helpful to remove the paper, turn the stack over and put it back into the paper tray.
	Reduce the amount of paper in the paper tray, and then try again.
	Clean the paper pick-up rollers. (See <i>Advanced User's Guide: Cleaning the paper pick-up rollers.</i>)
Photo paper does not feed correctly.	When you print on Brother Photo paper, load one extra sheet of the same photo paper in the paper tray. An extra sheet has been included in the paper package for this purpose.
Machine feeds multiple pages.	Do the following: (See <i>Loading paper and other print media</i> on page 20.)
	<ul style="list-style-type: none"> ■ Make sure the paper is loaded correctly in the paper tray. ■ Remove all the paper from the tray and fan the stack of paper well, then put it back in the tray. ■ Make sure you do not push the paper in too far.
	Make sure the Jam Clear Cover is closed correctly. (See <i>Printer jam or paper jam</i> on page 117.)
	Make sure the Base Pad in the paper tray is not dirty. (See <i>Advanced User's Guide: Cleaning the paper pick-up rollers.</i>)
	When using the manual feed slot, load only one sheet of paper at a time.
There is a paper jam.	See <i>Printer jam or paper jam</i> on page 117. Make sure the paper guides are set to the correct paper size. Do not extend the paper tray when you load A5 or smaller size paper.
Paper jam reoccurs.	If there is a repeat paper jam, a small piece of paper may be stuck in the machine. Make sure paper is not still jammed in the machine. (See <i>Additional paper jam clear operations</i> on page 121.)



Paper Handling Difficulties (continued)

Difficulties	Suggestions
The paper jams when you use 2-sided copy or 2-sided print.	Use one of the jam prevention settings, 2-sided 1 or 2-sided 2.
	For copying: (See Advanced User's Guide: <i>2-sided copying</i> .)
	For printing: (See Software and Network User's Guide.)
	If paper jams occur often during 2-sided copying or 2-sided printing, the paper feed rollers may be stained with ink. Clean the paper feed rollers. (See Advanced User's Guide: <i>Cleaning the paper feed rollers</i> .)

Printing Received Faxes

Difficulty	Suggestions
<ul style="list-style-type: none"> ■ Condensed print ■ Horizontal streaks ■ Top and bottom sentences are cut off ■ Missing lines 	Usually this is caused by a poor telephone connection. You can check this by making a test copy; if your copy looks good, you probably had a bad connection with static or interference on the telephone line. Ask the other party to re-send the fax.
Vertical black lines when receiving.	The sender's scanner may be dirty. Ask the sender to make a copy to see if the problem is with the sending machine. Try receiving from another fax machine.
Left and right margins are cut off or a single page is printed on two pages.	If the received faxes are divided and printed on two pages or if you get an extra blank page, your paper size setting may not be correct for the paper you are using. (See <i>Paper Size (MFC-J6520DW)</i> on page 37.)
	Turn on Auto Reduction. (See Advanced User's Guide: <i>Printing a reduced incoming fax</i> .)
Received colour fax prints only in monochrome.	Replace the colour ink cartridges that have reached the end of their life, and then ask the other person to send the colour fax again. (See <i>Replacing the ink cartridges</i> on page 94.)

Telephone Line or Connections

Difficulty	Suggestions
Dialling does not work. (No dial tone)	Check the line cord connections.
	Change the Tone/Pulse setting. (See Quick Setup Guide.)
	If there is no dial tone, connect a known-working telephone and telephone line cord to the socket. Then lift the external telephone's handset and listen for a dial tone. If there is still no dial tone, ask your telephone company to check the line and/or wall socket.
The machine does not answer when called.	Make sure the machine is in the correct Receive Mode for your setup. (See <i>Choose the Receive Mode</i> on page 52.) Check for a dial tone. If possible, call your machine to hear it answer. If there is still no answer, check the telephone line cord connection. If there is no ringing when you call your machine, ask your telephone company to check the line.

Receiving Faxes

Difficulty	Suggestions
<p>Cannot receive a fax.</p>	<p>Check all line cord connections. Make sure the telephone line cord is plugged into the telephone wall socket and the LINE socket inside the machine. If you subscribe to DSL or VoIP services, contact your service provider for connection instructions. To lower the modem speed and turn off ECM (error correction mode), see <i>Telephone line interference / VoIP</i> on page 135.</p> <p>Make sure the machine is in the correct Receive Mode. This is determined by the external devices and telephone subscriber services you have on the same line as the Brother machine. (See <i>Choose the Receive Mode</i> on page 52.)</p> <p>If you have a dedicated fax line and want your Brother machine to automatically answer all incoming faxes, select Fax Only mode.</p> <p>If your Brother machine shares a line with an external answering machine, select External TAD mode. In External TAD mode, your Brother machine will automatically receive incoming faxes and voice callers will be able to leave a message on your answering machine.</p> <p>If your Brother machine shares a line with other telephones and you want it to automatically answer all incoming faxes, select Fax/Tel mode. In Fax/Tel mode, your Brother machine will automatically receive faxes and produce a fast double-ring to alert you to answer voice calls.</p> <p>If you do not want your Brother machine to automatically answer incoming faxes, select Manual mode. In Manual mode, you must answer every incoming call and activate the machine to receive faxes.</p> <p>Another device or service at your location may be answering the call before your Brother machine answers. To test this, lower the Ring Delay setting:</p> <ul style="list-style-type: none"> ■ If the Receive Mode is set to Fax Only or Fax/Tel, reduce the Ring Delay to 1 ring. (See <i>Ring Delay</i> on page 55.) ■ If the Receive Mode is set to External TAD, reduce the number of rings programmed on your answering machine to 2. ■ If the Receive Mode is set to Manual, DO NOT adjust the Ring Delay setting. <p>Have someone send you a test fax:</p> <ul style="list-style-type: none"> ■ If you received the test fax successfully, your machine is operating correctly. Remember to reset your Ring Delay or answering machine setting back to your original setting. If receiving problems recur after resetting the Ring Delay, then a person, device, or subscriber service is answering the fax call before the machine has a chance to answer. ■ If you were not able to receive the fax, then another device or subscriber service may be interfering with your fax reception or there may be a problem with your fax line.



Receiving Faxes (continued)

Difficulty	Suggestions
Cannot receive a fax. (continued)	<p>If you are using a telephone answering machine (External TAD mode) on the same line as the Brother machine, make sure your answering machine is set up correctly. (See <i>Connecting an external TAD (telephone answering device)</i> on page 66.)</p> <ol style="list-style-type: none"> 1 Connect the external TAD as shown in the illustration on page 66. 2 Set your answering machine to answer in one or two rings. 3 Record the outgoing message on your answering machine. <ul style="list-style-type: none"> ■ Record five seconds of silence at the beginning of your outgoing message. ■ Limit your speaking to 20 seconds. ■ End your outgoing message with your Remote Activation Code for people sending manual faxes. For example: "After the beep, leave a message or press * 5 1 and Start to send a fax." 4 Set your answering machine to answer calls. 5 Set your Brother machine's Receive Mode to External TAD. (See <i>Choose the Receive Mode</i> on page 52.) <p>Make sure your Brother machine's Fax Detect feature is turned On. Fax Detect is a feature that allows you to receive a fax even if you have answered the call on an external or extension telephone. (See <i>Fax Detect</i> on page 56.)</p> <p>If you often get transmission errors due to possible interference on the telephone line, try changing the Compatibility setting to Basic (for VoIP). (See <i>Telephone line interference / VoIP</i> on page 135.)</p> <p>If you connect your machine to a PBX or ISDN line, set the menu setting of Telephone Line Type to your telephone line type. (See <i>Setting the Telephone Line Type</i> on page 64.)</p>

Sending Faxes

Difficulty	Suggestions
Cannot send a fax.	<p>Check all line cord connections. Make sure the telephone line cord is plugged into the telephone wall socket and the LINE socket inside the machine.</p> <p>Print the Transmission Verification Report and check for an error. (See <i>Advanced User's Guide: Reports</i>.)</p> <p>Contact your administrator to check your Secure Function Lock Settings.</p> <p>Ask the other party to check that the receiving machine has paper.</p>
Poor fax send quality.	<p>Try changing your resolution to Fine or S.Fine. Make a copy to check your machine's scanner operation. If the copy quality is poor, clean the scanner. (See <i>Cleaning the scanner glass</i> on page 97.)</p>

Sending Faxes (continued)

Difficulty	Suggestions
Transmission Verification Report says <code>RESULT:ERROR</code> .	There is probably temporary noise or static on the line. Try sending the fax again. If you send a PC FAX message and get <code>RESULT:ERROR</code> on the Transmission Verification Report, your machine may be out of memory. To gain extra memory, you can turn off Memory Receive (See Advanced User's Guide: <i>Turning off Memory Receive operations.</i>), print fax messages from the machine's memory (See Advanced User's Guide: <i>Printing a fax from the memory.</i>), or cancel a Delayed Fax or Polling Job. (See <i>Cancelling a fax in process</i> on page 49.) (See Advanced User's Guide: <i>Checking and cancelling waiting jobs.</i>) If the problem continues, ask the telephone company to check your telephone line.
	If you often get transmission errors due to possible interference on the telephone line, try changing the machine's Compatibility setting to <code>Basic</code> (for VoIP). (See <i>Telephone line interference / VoIP</i> on page 135.)
	If you connect your machine to PBX or ISDN, set the menu setting of Telephone Line Type to your telephone line type. (See <i>Setting the Telephone Line Type</i> on page 64.)
Vertical black lines when sending.	Black vertical lines on faxes you send are typically caused by dirt or correction fluid on the glass strip. Clean the glass strip. (See <i>Cleaning the scanner glass</i> on page 97.)

Handling Incoming Calls

Difficulty	Suggestions
The machine "hears" a voice as a CNG Tone.	If Fax Detect is set to <code>On</code> , your machine is more sensitive to sounds. It may mistakenly interpret certain voices or music on the line as a fax machine calling and respond with fax-receiving tones. Deactivate the machine by pressing  . Try avoiding this problem by turning Fax Detect to <code>Off</code> . (See <i>Fax Detect</i> on page 56.)
Sending a fax call to the machine.	If you answered on an extension or external telephone, press your Remote Activation Code (the factory default is * 5 1). If you answered on an external telephone, press <code>Fax Start</code> , and then press <code>Receive</code> to receive the fax. When your machine answers, hang up.
Custom features on a single line.	If you have Call Waiting, Call Waiting/Caller ID, Caller ID, Voice Mail, an answering machine, an alarm system or other custom feature on a single telephone line with your machine, it may create a problem sending or receiving faxes. For example: If you subscribe to Call Waiting or another custom service and its signal comes through the line while your machine is sending or receiving a fax, the signal can temporarily interrupt the faxes. Brother's ECM (Error Correction Mode) feature should help overcome this problem. This condition is related to the telephone system industry and is common to all devices that send and receive information on a single, shared line with custom features. If avoiding a slight interruption is crucial to your business, we recommend using a separate telephone line with no custom features.



Copying Difficulties

Difficulty	Suggestions
Cannot make a copy.	Contact your administrator to check your Secure Function Lock Settings.
Vertical black lines or streaks appear in copies.	Black vertical lines on copies are typically caused by dirt or correction fluid on the glass strip. Clean the glass strip, scanner glass, and the white bar and white plastic above them. (See <i>Cleaning the scanner glass</i> on page 97.)
Poor copy results when using the ADF.	Try using the scanner glass. (See <i>Using the scanner glass</i> on page 45.)
Fit to Page does not work correctly.	Make sure your source document is not skewed. Reposition the document and try again.

Scanning Difficulties

Difficulty	Suggestions
TWAIN or WIA errors appear when starting to scan. (Windows®)	Make sure the Brother TWAIN or WIA driver is chosen as the primary source in your scanning application. For example, in Nuance™ PaperPort™ 12SE, click Scan Settings, Select to choose the Brother TWAIN/WIA driver.
TWAIN or ICA errors appear when starting to scan. (Macintosh)	Make sure the Brother TWAIN driver is chosen as the primary source. In Presto! PageManager, click File, Select Source and choose the Brother TWAIN driver. You can also scan documents using the ICA Scanner Driver. (See Software and Network User's Guide.)
OCR does not work.	Try increasing the scanner resolution. (Macintosh) Presto! PageManager must be downloaded and installed before use. For more information, see <i>Accessing Brother Support (Macintosh)</i> on page 5.
Poor scanning results when using the ADF. ■ Vertical black lines appear in the scanned data.	Clean the white bar in the ADF and the glass strip underneath it. (See <i>Cleaning the scanner glass</i> on page 97.) Try using the scanner glass. (See <i>Using the scanner glass</i> on page 45.)

PhotoCapture Center™ Difficulties

Difficulty	Suggestions
Removable Disk does not work correctly.	<ol style="list-style-type: none"> 1 Take out the memory card or USB Flash drive and put it back in again. 2 If you have tried "Eject" from within Windows®, take out the memory card or USB Flash drive before you continue. 3 If an error message appears when you try to eject the memory card or USB Flash drive, it means the card is being accessed. Wait a while, and then try again. 4 If all of the above do not work, turn off your PC and machine, and then turn them on again.
Cannot access Removable Disk from the computer.	Make sure that you have correctly inserted the memory card or USB Flash drive.
Part of my photo is missing when printed.	Make sure that Borderless printing and Cropping are turned off. (See Advanced User's Guide: <i>Borderless printing</i> and <i>Cropping</i> .)

Software Difficulties

Difficulty	Suggestions
Cannot install software or print.	(Windows®) Run the Repair MFL-Pro Suite program on the CD-ROM. This program will repair and reinstall the software.
“Device Busy”	Make sure the machine is not showing an error message on the Touchscreen.

Network Difficulties

Difficulty	Suggestions
Cannot print over the network.	<p>Make sure that your machine is powered on and is online and in the Ready mode. Print a Network Configuration Report (see Advanced User's Guide: <i>Reports</i>) and check the current Network settings printed in this list.</p> <p>Reconnect the LAN cable to the hub to verify that the cabling and network connections are good. If possible, try connecting the machine to a different port on your hub using a different cable. If the connections are good, the machine shows LAN Active for 2 seconds.</p> <p>If you are using a wireless connection or are having network problems, see Software and Network User's Guide.</p>
The network scanning feature does not work.	<p>It is necessary to configure the third-party Security/Firewall Software to allow Network scanning. To add port 54925 for Network scanning, enter the information below:</p> <p>In Name: Enter any description, for example Brother NetScan.</p> <p>In Port number: Enter 54925.</p> <p>In Protocol: UDP is selected.</p> <p>Please refer to the instruction manual that came with your third-party Security/Firewall Software or contact the software manufacturer.</p> <p>(Macintosh)</p> <p>Select Other from the Model drop-down list in the main screen of ControlCenter2. In the Device Selector window, make sure Network is selected in Connection Type, and then click Browse. Reselect your network machine, and press OK.</p>
The network PC-Fax Receive feature does not work.	<p>(Windows®)</p> <p>It is necessary to set the third-party Security/Firewall Software to allow PC-FAX Rx. To add port 54926 for Network PC-FAX Rx, enter the information below:</p> <p>In Name: Enter any description, for example Brother PC-FAX Rx.</p> <p>In Port number: Enter 54926.</p> <p>In Protocol: UDP is selected.</p> <p>Please refer to the instruction manual that came with your third-party Security/Firewall Software or contact the software manufacturer.</p>
The Brother software cannot be installed.	<p>(Windows®)</p> <p>Allow network access to the following programs if your security software displays an alert message during MFL-Pro Suite installation.</p> <p>(Macintosh)</p> <p>If you are using a firewall function of anti-spyware or antivirus security software, temporarily disable it, and then install the Brother software.</p>

Network Difficulties (continued)



Difficulty	Suggestions
Cannot connect to wireless network.	Investigate the problem using the WLAN Report. Press  (Settings), All Settings, and then press ▲ or ▼ to display Print Reports. Press Print Reports. Press ▲ or ▼ to display WLAN Report, and then press WLAN Report. (See Software and Network User's Guide.)

Difficulties when entering data

Difficulty	Suggestions
The dial pad does not work when entering numbers or characters.	Use the keyboard on the Touchscreen to enter information.

Dial Tone detection

When you send a fax automatically, by default your machine will wait for a fixed amount of time before it starts to dial the number. By changing the Dial Tone setting to Detection, you can make your machine dial as soon as it detects a dial tone. This setting can save a small amount of time when sending a fax to many different numbers. If you change the setting and start having problems when dialling, you should change it back to the No Detection setting.

- 1 Press  (Settings).
- 2 Press All Settings.
- 3 Press ▲ or ▼ to display Initial Setup.
- 4 Press Initial Setup.
- 5 Press ▲ or ▼ to display Dial Tone.
- 6 Press Dial Tone.
- 7 Press Detection or No Detection.
- 8 Press .

Telephone line interference / VoIP

If you are having problems sending or receiving a fax due to possible interference on the telephone line, you can change the compatibility setting which reduces the modem speed to minimise errors.

- 1 Press  (Settings).
- 2 Press All Settings.
- 3 Press ▲ or ▼ to display Initial Setup.
- 4 Press Initial Setup.

- 5 Press ▲ or ▼ to display Compatibility.
- 6 Press Compatibility.
- 7 Press High, Normal or Basic (for VoIP).
 - Basic (for VoIP) cuts the modem speed to 9,600 bps and turns off colour fax receiving and ECM, except for colour fax-sending. Unless interference is a recurring problem on your telephone line, you may prefer to use it only when needed.

To improve compatibility with most VoIP services, Brother recommends changing the compatibility setting to Basic (for VoIP).

 - Normal sets the modem speed at 14,400 bps.
 - High increases the modem speed to 33,600 bps. (factory default)
- 8 Press .



NOTE

VoIP (Voice over IP) is a type of phone system that uses an Internet connection, rather than a traditional phone line.

Machine Information

Checking the serial number

You can see the machine's serial number on the Touchscreen.

- 1 Press  (Settings).
- 2 Press All Settings.
- 3 Press ▲ or ▼ to display Machine Info.
- 4 Press Machine Info.
- 5 Press Serial No.
Your machine's serial number will appear on the Touchscreen.
- 6 Press .

Checking the firmware version

You can see the machine's firmware version on the Touchscreen.

- 1 Press  (Settings).
- 2 Press All Settings.
- 3 Press ▲ or ▼ to display Machine Info.
- 4 Press Machine Info.
- 5 Press Firmware Version.
- 6 Press Main Version.
Your machine's firmware version will appear on the Touchscreen.
- 7 Press .

Reset functions

The following reset functions are available:

- 1 Machine Reset
You can reset all the machine's settings that you have changed, such as Date and Time, telephone line type and Ring Delay.
- 2 Network
You can reset the print server back to its default factory settings, such as the password and IP address information.
- 3 Address Book & Fax
Address Book & Fax resets the following settings:
 - Address Book
(Address Book and Setup Groups)
 - Programmed fax jobs in the memory
(Polled Transmit, Delayed Fax and Delayed Batch Transmission)
 - Station ID
(Name and Number)
 - Remote Fax Options
(Fax Forwarding)
 - Report settings
(Transmission Verification Report, Address Book and Fax Journal)
 - History
(Caller ID history and Outgoing Call)
 - Faxes in memory
- 4 All Settings
You can restore all settings to the factory default.
Brother strongly recommends performing this procedure before handing over or disposing of the machine.

NOTE

Unplug the interface cable before you choose Network or All Settings.

How to reset the machine

- 1 Press  (Settings).
- 2 Press All Settings.
- 3 Press ▲ or ▼ to display Initial Setup.
- 4 Press Initial Setup.
- 5 Press ▲ or ▼ to display Reset.
- 6 Press Reset.
- 7 Press ▲ or ▼ to display the type of reset (Machine Reset, Network, Address Book & Fax **OR** All Settings), and then press it.
- 8 Press Yes to confirm.
- 9 Press Yes for 2 seconds to reboot the machine.

C

Settings and feature tables

Using the Settings tables

Your machine's Touchscreen LCD is easy to set up and operate. All you have to do is press the settings and options you want to set as they are displayed on the screen.



We have created step-by-step Settings tables and Feature tables so you can see at-a-glance all the available choices for each setting and feature. You can use these tables to quickly choose your preferred settings in the machine.



Settings tables

The Settings tables will help you understand the settings selections that are found in the machine's programs. The factory settings are shown in Bold with an asterisk.



(Settings)

Level1	Level2	Level3	Options	Descriptions	Page
Ink	(See <i>(Ink)</i> on page 184.)				
Wi-Fi	TCP/IP	—	—	Lets you configure the TCP/IP protocol.	See †.
	WLAN Assistant	—	—	You can configure your wireless network settings using the Brother CD-ROM.	
	Setup Wizard	—	—	You can manually configure your print server for a wireless network.	See ‡.
	WPS/AOSS	—	—	You can easily configure your wireless network settings using the one-button push method.	
	WPS w/ PIN Code	—	—	You can easily configure your wireless network settings using WPS with a PIN.	See †.
	WLAN Status	—	—	You can see the current wireless network status.	
	MAC Address	—	—	You can see your machine's MAC address.	
 (Paper Type) (MFC-J6520DW)	—	—	Plain Paper* Inkjet Paper Brother BP71 Other Glossy Transparency	Sets the type of paper in the paper tray.	37
 (Paper Size) (MFC-J6520DW)	—	—	A4* A5 A3 10x15cm Letter Legal Ledger	Sets the size of paper in the paper tray.	37
† See Software and Network User's Guide. ‡ See Quick Setup Guide.					
The default settings are shown in Bold with an asterisk.					

Level1	Level2	Level3	Options	Descriptions	Page
 (Tray#1) (MFC-J6720DW)	Paper Type	—	Plain Paper* Inkjet Paper Brother BP71 Other Glossy Transparency	Sets the type of paper in paper tray #1.	37
	Paper Size	—	A4* A5 A3 10x15cm Letter Legal Ledger	Sets the size of paper in paper tray #1.	
 (Tray#2) (MFC-J6720DW)	Paper Size	—	A4* A3 Letter Legal Ledger	Sets the size of paper in paper tray #2.	37
Fax Preview	—	—	On Off*	You can view faxes you receive on the Touchscreen.	57
All Settings	—	—	For more information, see <i>All Settings</i> in the following table.	Configures the detailed settings.	—
† See Software and Network User's Guide. ‡ See Quick Setup Guide.					
The default settings are shown in Bold with an asterisk.					



All Settings

Level1	Level2	Level3	Options	Descriptions	Page
General Setup	Ink	Test Print	Print Quality Alignment	Lets you check the print quality or alignment.	98 100
		Cleaning	Black Colour All	Lets you clean the print head.	98
		Ink Volume	—	Lets you check the available ink volume.	See ♦.
	Paper Type (MFC-J6520DW)	—	Plain Paper* Inkjet Paper Brother BP71 Other Glossy Transparency	Sets the type of paper in paper tray.	37
	Paper Size (MFC-J6520DW)	—	A4* A5 A3 10x15cm Letter Legal Ledger	Sets the size of paper in paper tray.	37

♦ See Advanced User's Guide.

The default settings are shown in Bold with an asterisk.

Level1	Level2	Level3	Options	Descriptions	Page
General Setup (Continued)	Tray Setting (MFC-J6720DW)	Tray #1	Paper Type (Options) Plain Paper* Inkjet Paper Brother BP71 Other Glossy Transparency	Sets the type of paper in paper tray #1.	37
			Paper Size (Options) A4* A5 A3 10x15cm Letter Legal Ledger	Sets the size of paper in paper tray #1.	
		Tray #2	Paper Size (Options) A4* A3 Letter Legal Ledger	Sets the size of paper in paper tray #2.	37
		Tray Use: Copy	Tray #1 Tray #2 Auto Tray Select*	Choose the tray that will be used for copying.	38
		Tray Use: Fax	Tray #1 Tray #2 Auto Tray Select*	Choose the tray that will be used for faxing.	39
◆ See Advanced User's Guide.					
The default settings are shown in Bold with an asterisk.					

Level1	Level2	Level3	Options	Descriptions	Page
General Setup (Continued)	Volume	Ring	Off Low Med* High	Adjusts the ring volume.	18
		Beep	Off Low* Med High	Adjusts the volume of the sounds when you press the Touchscreen or Touchpanel.	18
		Speaker	Off Low Med* High	Adjusts the speaker volume.	19
	LCD Settings	Backlight	Light* Med Dark	You can adjust the brightness of the Touchscreen backlight.	19
		Dim Timer	Off 10Secs 20Secs 30Secs*	You can set how long the Touchscreen backlight stays on after the last finger press.	See ♦.
	Keyboard Settings	—	QWERTY* ABC	You can choose the type of keyboard for the Touchscreen.	12
	Sleep Mode	—	1Min 2Mins 3Mins 5Mins* 10Mins 30Mins 60Mins	You can choose how long the machine will remain idle before it goes into Sleep Mode.	See ♦.
	Function Lock	Set Password	—	You can restrict selected machine operations for up to 10 restricted users and for all other non-authorized Public users.	
		Lock Off-On	—		
	Shortcut Settings	Shortcut Name	Edit Shortcut Name	—	You can change the shortcut name.
Delete			—	Deletes the shortcut.	17
♦ See Advanced User's Guide.					
The default settings are shown in Bold with an asterisk.					

Level1	Level2	Level3	Options	Descriptions	Page
Fax	Setup Receive	Receive Mode	Fax Only* Fax/Tel External TAD Manual	Choose the Receive Mode that best suits your needs.	52
		Ring Delay	0 1 2* 3 4 5 6 7 8 (Example for the U.K.)	Sets the number of rings before the machine answers in Fax Only or Fax/Tel mode.	55
		F/T Ring Time	20Secs 30Secs* 40Secs 70Secs	Sets the length of the fast double-ring time in Fax/Tel mode.	55
		Fax Preview	On Off*	You can view received faxes on the Touchscreen.	57
		Fax Detect	On* Off	Receives fax messages automatically when you answer a call and hear fax tones.	56
		Remote Codes	Remote Codes (Options) On* Off Act.Code (*51) Deact.Code (#51)	Allows you to answer all calls at an extension or external telephone and use codes to turn the machine on or off. You can personalize these codes.	69

◆ See Advanced User's Guide.

The default settings are shown in Bold with an asterisk.

Level1	Level2	Level3	Options	Descriptions	Page
Fax (Continued)	Setup Receive (Continued)	Auto Reduction	On* Off	Cuts the size of incoming faxes to fit the paper size.	See ◆.
		Memory Receive	Off* Fax Forward Fax Storage PC Fax Receive	You can set the machine to either forward fax messages, store incoming faxes in the memory (so you can retrieve them while you are away from your machine) or send faxes to your PC. If you choose Fax Forward or PC Fax Receive, you can turn on the Backup Print safety feature.	
	Report Setting	XMIT Report	On On+Image Off* Off+Image Off2 Off2+Image	Choose the initial setup for the Transmission Verification Report.	51
		Journal Period	Journal Period	Sets the interval for the automatic printing of the Fax Journal. If you have chosen any other option than Off and Every 50 Faxes, you can set the time for the chosen option. If you have chosen Every 7 Days, you can set the day of the week.	See ◆.
			Time		
	Day				
	Print Document	—	—	Prints incoming faxes stored in the memory.	
Remote Access	—	---*	Set your own code for Remote Retrieval.		
◆ See Advanced User's Guide.					
The default settings are shown in Bold with an asterisk.					

Level1	Level2	Level3	Options	Descriptions	Page
Fax (Continued)	Dial Restriction	Dial Pad	Enter # Twice On Off*	You can set whether to restrict fax transmissions, or require that the user enters the number twice in order to prevent transmissions to an incorrect address.	See ♦.
		Address Book	Enter # Twice On Off*		
		Shortcuts	Enter # Twice On Off*		
		LDAP Server	Enter # Twice On Off*		
	Remaining Jobs	—	—	Check which jobs are in the memory and cancel chosen jobs.	
	Miscellaneous	BT Call Sign (U.K. Only)	On Off*	Use with BT Call Sign.	
Caller ID (U.K. and Ireland only)		On* Off	View or print a list of the last 30 Caller IDs stored in the memory.	63	
♦ See Advanced User's Guide.					
The default settings are shown in Bold with an asterisk.					

Level1	Level2	Level3	Level4	Options	Descriptions	Page
Network	Wired LAN	TCP/IP	BOOT Method	Auto* Static RARP BOOTP DHCP	Choose the BOOT method that best suits your needs.	See +.
			IP Address	[000-255]. [000-255]. [000-255]. [000-255]	Enter the IP address.	
			Subnet Mask	[000-255]. [000-255]. [000-255]. [000-255]	Enter the Subnet mask.	
			Gateway	[000-255]. [000-255]. [000-255]. [000-255]	Enter the Gateway address.	
			Node Name	BRNXXXXXXXXXXXX	Enter the Node name.	
			WINS Configuration	Auto* Static	Chooses the WINS configuration mode.	
			WINS Server	(Primary) 000.000.000.000 (Secondary) 000.000.000.000	Specifies the IP address of the primary or secondary WINS server.	
			DNS Server	(Primary) 000.000.000.000 (Secondary) 000.000.000.000	Specifies the IP address of the primary or secondary DNS server.	
			APIPA	On* Off	Automatically allocates the IP address from the link-local address range.	
<p>+ See Software and Network User's Guide.</p> <p>♣ Please go to the Brother Solutions Center to download the Wi-Fi Direct™ Guide at http://solutions.brother.com/.</p> <p>● Please go to the Brother Solutions Center to download the Web Connect Guide at http://solutions.brother.com/.</p> <p>The default settings are shown in Bold with an asterisk.</p>						

Level1	Level2	Level3	Level4	Options	Descriptions	Page
Network (Continued)	Wired LAN (Continued)	TCP/IP (Continued)	IPv6	On Off*	Enable or disable the IPv6 protocol. If you want to use the IPv6 protocol, visit http://solutions.brother.com/ for more information.	See †.
		Ethernet	—	Auto* 100B-FD 100B-HD 10B-FD 10B-HD	Chooses the Ethernet link mode.	
		Wired Status	—	Active 100B-FD Active 100B-HD Active 10B-FD Active 10B-HD Inactive Wired OFF	You can see the current wired network status.	
		MAC Address	—	—	You can see your machine's MAC address.	
	WLAN	TCP/IP	BOOT Method	Auto* Static RARP BOOTP DHCP	Chooses the BOOT method that best suits your needs.	
				IP Address	[000-255]. [000-255]. [000-255]. [000-255]	

† See Software and Network User's Guide.

♣ Please go to the Brother Solutions Center to download the Wi-Fi Direct™ Guide at <http://solutions.brother.com/>.

● Please go to the Brother Solutions Center to download the Web Connect Guide at <http://solutions.brother.com/>.

The default settings are shown in Bold with an asterisk.

Level1	Level2	Level3	Level4	Options	Descriptions	Page
Network (Continued)	WLAN (Continued)	TCP/IP (Continued)	Subnet Mask	[000-255]. [000-255]. [000-255]. [000-255]	Enter the Subnet mask.	See +.
			Gateway	[000-255]. [000-255]. [000-255]. [000-255]	Enter the Gateway address.	
			Node Name	BRWXXXXXXXXXXXX	Enter the Node name.	
			WINS Configuration	Auto* Static	Chooses the WINS configuration mode.	
			WINS Server	(Primary) 000.000.000.000 (Secondary) 000.000.000.000	Specifies the IP address of the primary or secondary WINS server.	
			DNS Server	(Primary) 000.000.000.000 (Secondary) 000.000.000.000	Specifies the IP address of the primary or secondary DNS server.	
			APIPA	On* Off	Automatically allocates the IP address from the link-local address range.	
			IPv6	On Off*	Enable or disable IPv6 protocol for a wireless LAN. If you want to use the IPv6 protocol, visit http://solutions.brother.com/ for more information.	

+ See Software and Network User's Guide.

♣ Please go to the Brother Solutions Center to download the Wi-Fi Direct™ Guide at <http://solutions.brother.com/>.

● Please go to the Brother Solutions Center to download the Web Connect Guide at <http://solutions.brother.com/>.

The default settings are shown in Bold with an asterisk.

Level1	Level2	Level3	Level4	Options	Descriptions	Page
Network (Continued)	WLAN (Continued)	WLAN Assistant	—	—	You can configure your wireless network settings using the Brother CD-ROM.	See †.
		Setup Wizard	—	—	You can manually configure your print server for a wireless network.	
		WPS/AOSS	—	—	You can easily configure your wireless network settings using the one-button push method.	
		WPS w/ PIN Code	—	—	You can easily configure your wireless network settings using WPS with a PIN.	
		WLAN Status	Status	—	You can see the current wireless network status.	
			Signal	—	You can see the current wireless network signal strength.	
			SSID	—	You can see the current SSID.	
			Comm. Mode	—	You can see the current Communication Mode.	
		MAC Address	—	—	You can see your machine's MAC address.	

† See Software and Network User's Guide.

♣ Please go to the Brother Solutions Center to download the Wi-Fi Direct™ Guide at <http://solutions.brother.com/>.

● Please go to the Brother Solutions Center to download the Web Connect Guide at <http://solutions.brother.com/>.

The default settings are shown in Bold with an asterisk.

Level1	Level2	Level3	Level4	Options	Descriptions	Page
Network (Continued)	Wi-Fi Direct	Push Button	—	—	You can easily configure your Wi-Fi Direct™ network settings using the one-button push method.	See ♣.
		PIN Code	—	—	You can easily configure your Wi-Fi Direct™ network settings using WPS with a PIN.	
		Manual	—	—	You can manually configure your Wi-Fi Direct™ network settings.	
		Group Owner	—	On Off*	Sets your machine as the Group Owner.	
		Device Information	Device Name	—	You can see the device name of your machine.	
			SSID	—	Shows SSID of Group Owner. When the machine is not connected, Touchscreen shows Not Connected.	
			IP Address	—	You can see the current IP address of your machine.	

+ See Software and Network User's Guide.

♣ Please go to the Brother Solutions Center to download the Wi-Fi Direct™ Guide at <http://solutions.brother.com/>.

● Please go to the Brother Solutions Center to download the Web Connect Guide at <http://solutions.brother.com/>.

The default settings are shown in Bold with an asterisk.

Level1	Level2	Level3	Level4	Options	Descriptions	Page
Network (Continued)	Wi-Fi Direct (Continued)	Status Information	Status	G/O Active (**) Client Active Not Connected Off ** = the number of devices	You can see the current Wi-Fi Direct™ network status.	See ♣.
			Signal	Strong Medium Weak None	You can see the current Wi-Fi Direct™ network signal strength. When your machine acts as Group Owner, the Touchscreen always shows Strong.	
		I/F Enable	—	On Off*	Enable or Disable the Wi-Fi Direct™ connection.	

† See Software and Network User's Guide.

♣ Please go to the Brother Solutions Center to download the Wi-Fi Direct™ Guide at <http://solutions.brother.com/>.

● Please go to the Brother Solutions Center to download the Web Connect Guide at <http://solutions.brother.com/>.

The default settings are shown in Bold with an asterisk.

Level1	Level2	Level3	Level4	Options	Descriptions	Page		
Network (Continued)	E-mail/IFAX (Available after IFAX is downloaded)	Mail Address	—	—	Enter the mail address. (Up to 60 characters)	See +.		
		Setup Server	SMTP Server	Name (Up to 30 characters)	None* SMTP-AUTH POP bef. SMTP		Enter the SMTP server address.	
				IP Address [000-255]. [000-255]. [000-255]. [000-255]				
				SMTP Port			[00001-65535]	Enter the SMTP port number.
				SMTP SSL/TLS			None* SSL TLS	Send or receive an E-mail via an E-mail server that requires secure SSL/TLS communication.
				Verify SMTPCert.			On Off*	Verify the SMTP Server Certificate automatically.
				POP3 Server			Name (Up to 30 characters) IP Address [000-255]. [000-255]. [000-255]. [000-255]	Enter the POP3 server address.
				POP3 Port			[00001-65535]	Enter the POP3 port number.
				Mailbox Name			—	Enter the mail box name. (Up to 60 characters)
Mailbox Password	—	Enter the password to login to the POP3 server. (Up to 32 characters)						

+ See Software and Network User's Guide.

♣ Please go to the Brother Solutions Center to download the Wi-Fi Direct™ Guide at <http://solutions.brother.com/>.

● Please go to the Brother Solutions Center to download the Web Connect Guide at <http://solutions.brother.com/>.

The default settings are shown in Bold with an asterisk.

Level1	Level2	Level3	Level4	Options	Descriptions	Page
Network (Continued)	E-mail/IFAX (Available after IFAX is downloaded) (Continued)	Setup Server (Continued)	POP3 SSL/TLS	None* SSL TLS	You can send or receive an E-mail via an E-mail server that requires secure SSL/TLS communication.	See +.
			Verify POP3Cert.	On Off*	Verify the POP3 Server Certificate automatically.	
			APOP	On Off*	Enables or disables APOP.	
		Setup Mail RX	Auto Polling	Auto Polling (Options) On* Off	Automatically checks the POP3 server for new messages.	
				(When On chosen) Poll Frequency (Options) 1Min 3Mins 5Mins 10Mins* 30Mins 60Mins	Sets the interval for checking for new messages on the POP3 server.	
			Header	All Subject+From+To None*	Selects the contents of the mail header to be printed.	
			Delete Error Mail	On* Off	Deletes error mails automatically.	
			Notification	On MDN Off*	Receives notification messages.	

+ See Software and Network User's Guide.

♣ Please go to the Brother Solutions Center to download the Wi-Fi Direct™ Guide at <http://solutions.brother.com/>.

● Please go to the Brother Solutions Center to download the Web Connect Guide at <http://solutions.brother.com/>.

The default settings are shown in Bold with an asterisk.

Level1	Level2	Level3	Level4	Options	Descriptions	Page		
Network (Continued)	E-mail/IFAX (Available after IFAX is downloaded) (Continued)	Setup Mail TX	Sender Subject	—	Displays the subject that is attached to the Internet Fax data.	See +.		
			Size Limit	On Off*	Limits the size of E-mail documents.			
			Notification	On Off*	Sends notification messages.			
		Setup Relay	Relay Broadcast	On Off*	Relays a document to another fax machine over the Internet.			
			Relay Domain	—	Registers the Domain name.			
			Relay Report	On Off*	Prints the Relay Broadcast Report.			
		Manual POP3 Receive	—	—	Accesses the POP3 server and confirms whether an e- mail has been received.			
		Web Connect Settings	Proxy Settings	Proxy Connection	On Off*		You can change the Web connection settings.	See ●.
				Address	—			
				Port	—			
	User Name			—				
	Password			—				
	Network I/F	—	—	Wired LAN* WLAN	You can choose the network connection type.	See +.		
Network Reset	—	—	Yes No	Restores all network settings back to the factory default.				

+ See Software and Network User's Guide.

♣ Please go to the Brother Solutions Center to download the Wi-Fi Direct™ Guide at <http://solutions.brother.com/>.

● Please go to the Brother Solutions Center to download the Web Connect Guide at <http://solutions.brother.com/>.

The default settings are shown in Bold with an asterisk.



All Settings (continued)

Level1	Level2	Level3	Options	Descriptions	Page	
Print Reports	XMIT Verify	—	—	Prints these lists and reports.	See ◆.	
	Address Book	—	—			
	Fax Journal	—	—			
	User Settings	—	—			
	Network Configuration	—	—			
	WLAN Report	—	—			
	Caller ID history	—	—			
Machine Info.	Serial No.	—	—	Lets you check the serial number of your machine.	136	
	Firmware Version	Main Version	—	Lets you check the firmware version of your machine.	136	
Initial Setup	Date & Time	Date	—	Sets the date and time on the screen and in the headings of the faxes you send.	101	
		Time	—			
		Auto Daylight	On* Off	Automatically changes for Daylight Savings Time.		See ◆.
		Time Zone	—	Sets the time zone for your country.		See ‡.
	Station ID	Fax Name	—	Enter your name and fax number to appear on each page you fax.		
	Tone/Pulse	—	Tone* Pulse	Choose the dialling mode.		
	Dial Tone	—	Detection No Detection*	Turns Dial Tone Detection on or off.	135	
	Phone Line Set	—	Normal* PBX ISDN	Choose the telephone line type.	64	
	Compatibility	—	High* Normal Basic(for VoIP)	Adjusts the modem speed to help resolve transmission problems.	135	

◆ See Advanced User's Guide.

‡ See Quick Setup Guide.

+ See Software and Network User's Guide.

The default settings are shown in Bold with an asterisk.

Level1	Level2	Level3	Options	Descriptions	Page
Initial Setup (Continued)	Reset	Machine Reset	Yes No	You can reset all the machine's settings that you have changed, such as Date and Time, telephone line type and Ring Delay.	136
		Network	Yes No	Resets the print server back to its factory default settings, such as the password and IP address information.	
		Address Book & Fax	Yes No	Deletes all stored Address Book numbers and faxes, restores the Station ID, Address Book List, Transmission Verification Report and Fax Journal back to the factory default settings.	
		All Settings	Yes No	Resets all the machine's settings back to the factory default.	
<p>◆ See Advanced User's Guide.</p> <p>‡ See Quick Setup Guide.</p> <p>+ See Software and Network User's Guide.</p>					
The default settings are shown in Bold with an asterisk.					

Feature tables



Fax (When Fax Preview is Off.)

Level1	Level2	Level3	Options	Descriptions	Page
Redial (Pause)	—	—	—	Redials the last number called. When you are entering a fax or telephone number on the Touchpanel, Redial changes to Pause on the Touchscreen. Press Pause when you need a delay while dialling numbers, such as access codes and credit card numbers. You can also store a pause when you set up addresses.	72
Te1 (R)	—	—	—	Te1 changes to R when PBX is selected as the telephone line type. You can use R to gain access to an outside line or to transfer a call to another extension when connected to a PBX.	64
◆ See Advanced User's Guide.					
The default settings are shown in Bold with an asterisk.					

Level1	Level2	Level3	Options	Descriptions	Page
Address Book	 (Search:)	—	—	When LDAP is off, the search will be within the Local Address Book. When LDAP is on, the search will be within the Local Address Book and LDAP Server.	71
		Detail (This will appear only when LDAP is on.)	—	Displays detailed information about the selected address.	
	Edit	—	Add New Address	Stores Address Book numbers so you can dial by pressing Address Book on the Touchscreen (and Apply , then Fax Start).	74
			Setup Groups	You can set up Group numbers for Broadcasting.	
			Change	You can change Address Book numbers.	75
			Delete	You can delete Address Book numbers.	
	—	Apply	—	You can send a fax using the Address Book.	71
Call History	Outgoing Call	Apply	—	You can choose a number from the Outgoing Call history and then send a fax to it, add it to the Address Book, or delete it.	72
		Edit	Add to Address Book Delete		
	Caller ID history	Apply	—	You can choose a number from the Caller ID history and then send a fax to it, add it to the Address Book, or delete it.	73
		Edit	Add to Address Book Delete		
◆ See Advanced User's Guide.					
The default settings are shown in Bold with an asterisk.					

Level1	Level2	Level3	Options	Descriptions	Page	
Options	Fax Resolution	—	Standard* Fine S.Fine Photo	Sets the resolution for outgoing faxes.	See ◆.	
	Contrast	—	Auto* Light Dark	Changes the brightness of faxes you send.		
	Glass Scan Size	—	A4* A3 Letter Legal Ledger	Sets the glass scan size for faxes.	49	
	Broadcasting	Add Number	Add Number	Add from Address book Search in Address book	You can send the same fax message to more than one fax number.	See ◆.
			Add from Address book			
			Search in Address book			
	Preview	—	On Off*	You can preview a fax message before you send it.	50	
	Colour Setting	—	Mono* Colour	Sets whether faxes are sent in monochrome or colour.	49	
	Delayed Fax	Delayed Fax	On Off*	Sets the time of day in 24-hour format that the delayed faxes will be sent.	See ◆.	
		Set Time	—			
	Batch TX	—	On Off*	Combines delayed faxes to the same fax number at the same time of day into one transmission.		
	Real Time TX	—	On Off*	You can send a fax without using the memory.		
	Polled TX	—	Standard Secure Off*	Sets up the document on your machine to be retrieved by another fax machine.		
Polling RX	—	Standard Secure Timer Off*	Sets up your machine to poll another fax machine.			

◆ See Advanced User's Guide.

The default settings are shown in Bold with an asterisk.

Level1	Level2	Level3	Options	Descriptions	Page	
Options (Continued)	Overseas Mode	—	On Off*	If you are having difficulty sending faxes overseas, set this to On.	See ◆.	
	Call History	Outgoing Call	Apply	You can choose a number from the Outgoing Call history and then send a fax to it, add it to the Address Book, or delete it.		
			Edit (Options) Add to Address Book Delete			
		Caller ID history	Apply	You can choose a number from the Caller ID history and then send a fax to it, add it to the Address Book, or delete it.		
			Edit (Options) Add to Address Book Delete			
	Address Book	 (Search:)	—	—	The search will be within the Address Book.	71
			Edit	Add New Address	You can store Address Book numbers, so you can dial by pressing Address Book on the Touchscreen (and Apply, then Fax Start).	74
				Setup Groups	You can set up Group numbers for Broadcasting.	See ◆.
				Change	You can change Address Book numbers.	75
			—	Delete	You can delete Address Book numbers.	
	—	—	Apply	You can send a fax using the Address Book.	71	
	Set New Default	—	Yes No	You can save your fax settings.	See ◆.	
	Factory Reset	—	Yes No	You can restore all settings back to the factory default.		
Save as Shortcut	—	—	—	Saves the current settings as a shortcut.		
◆ See Advanced User's Guide.						
The default settings are shown in Bold with an asterisk.						



Fax (When Fax Preview is On.)

Level1	Level2	Level3	Options	Descriptions	Page
Sending Faxes	(See <i>Fax (When Fax Preview is Off.)</i> on page 158.)				
Received Faxes	Print/Delete	Print All (New Faxes)	—	Prints the new received faxes.	59
		Print All (Old Faxes)	—	Prints the old received faxes.	
		Delete All (New Faxes)	—	Deletes the new received faxes.	59
		Delete All (Old Faxes)	—	Deletes the old received faxes.	
Address Book	(See <i>Address Book</i> in <i>Fax (When Fax Preview is Off.)</i> on page 158.)				
Call History	(See <i>Call History</i> in <i>Fax (When Fax Preview is Off.)</i> on page 158.)				
The default settings are shown in Bold with an asterisk.					



Copy

Level1	Level2	Level3	Options	Descriptions	Page
Options	ADF HighSpeed Mode	—	On Off*	You can copy A4 or Letter documents faster by placing them long side edge first in the ADF.	78
	Quality	—	Normal* Best	Choose the Copy resolution for the next copy.	See ♦.
	Paper Type	—	Plain Paper* Inkjet Paper Brother BP71 Other Glossy Transparency (MFC-J6720DW, when Tray #2 is selected in Tray Select.) Plain Paper	Choose the paper type that matches the paper in the tray.	77
♦ See Advanced User's Guide.					
The default settings are shown in Bold with an asterisk.					

Level1	Level2	Level3	Options	Descriptions	Page	
Options (Continued)	Paper Size	—	A4* A5 A3 10x15cm Letter Legal Ledger (MFC-J6720DW, when Tray #2 is selected in Tray Select.) A4* A3 Letter Legal Ledger	Choose the paper size that matches the paper in the tray.	77	
	Tray Select (MFC-J6720DW)	—	Tray #1 Tray #2 Auto Tray Select*	Choose the tray that will be used for Copy mode.	78	
	Enlarge/Reduce	100%*	—	—	—	See ◆.
		Enlarge	198% 10x15cm → A4 186% 10x15cm → Letter 141% A4→A3, A5→A4	—	You can choose the enlargement ratio for the next copy.	
		Reduce	97% Letter → A4 93% A4 → Letter 83% Legal → A4 69% A3 → A4, A4 → A5 47% A4 → 10x15cm	—	You can choose the reduction ratio for the next copy.	
Fit to Page		—	—	Your machine will adjust the size of the next copy to the paper size you set.		
	Custom (25-400%)	—	—	You can choose the enlargement or reduction ratio for your type of document.		
◆ See Advanced User's Guide.						
The default settings are shown in Bold with an asterisk.						

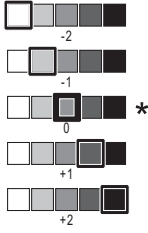
Level1	Level2	Level3	Options	Descriptions	Page
Options (Continued)	Density	—		Adjusts the density of copies.	See ◆ .
	Stack/Sort	—	Stack* Sort	You can choose to stack or sort multiple copies.	
	Page Layout	—	Off (1in1)* 2in1 (Portrait) 2in1 (Landscape) 2in1 (ID) 4in1 (Portrait) 4in1 (Landscape) 1 to 2 Poster (2x1) Poster (2x2) Poster (3x3)	You can make N in 1, 2 in 1 ID, 1 to 2, or Poster copies.	
	Layout Format (When you set Ledger or A3, and then choose 2 in 1 or Poster 2x2)	—	(When 2 in 1 is chosen.) Ledgerx2 → Ledgerx1 Letterx2 → Ledgerx1 A3x2 → A3x1 A4x2 → A3x1 (When Poster 2x2 is chosen) Ledgerx1 → Ledgerx4 Letterx1 → Ledgerx4 A3x1 → A3x4 A4x1 → A3x4		
	Auto Deskew	—	Auto* Off	If your scanned copy is skewed, your machine can correct the data automatically.	
◆ See Advanced User's Guide.					
The default settings are shown in Bold with an asterisk.					

Level1	Level2	Level3	Options	Descriptions	Page
Options (Continued)	2-sided Copy	Off*	—	You can choose the 2-sided print settings.	See ◆.
		Portrait Long Edge Flip	—		
		Landscape Long Edge Flip	—		
		Portrait Short Edge Flip	—		
		Landscape Short Edge Flip	—		
		Advanced	Normal* 2-sided 1 2-sided 2		
	Advanced Settings	—	Off* Ink Save Mode Thin Paper Copy Book Copy Watermark Copy Remove Background Colour	You can choose various copy settings.	
	Set New Default	—	Yes No	You can save your copy settings.	
	Factory Reset	—	Yes No	You can restore all the settings back to the factory default.	
	Save as Shortcut	—	—	Saves the current settings as a shortcut.	
◆ See Advanced User's Guide.					
The default settings are shown in Bold with an asterisk.					



Scan

Level1	Level2	Level3	Options	Descriptions	Page
to OCR (Available after Presto! PageManager is downloaded for Macintosh users. See <i>Accessing Brother Support (Macintosh)</i> on page 5.)	PC Select	Options	(For more information, see the <i>Options</i> on page 168.)	Configure the detailed settings.	See +.
		Save as Shortcut	—	Saves the current settings as a shortcut.	
to File*	PC Select	Options	(For more information, see the <i>Options</i> on page 169.)	Configure the detailed settings.	
		Save as Shortcut	—	Saves the current settings as a shortcut.	
to Image	PC Select	Options	(For more information, see the <i>Options</i> on page 169.)	Configure the detailed settings.	
		Save as Shortcut	—	Saves the current settings as a shortcut.	
to Media (when a memory card or USB Flash drive is inserted)	—	Options	(For more information, see the <i>Options</i> on page 170.)	Configure the detailed settings.	83
		Save as Shortcut	—	Saves the current settings as a shortcut.	See ◆.
to E-mail	PC Select	Options	(For more information, see the <i>Options</i> on page 169.)	Configure the detailed settings.	See +.
		Save as Shortcut	—	Saves the current settings as a shortcut.	
to E-mail Server (Available after IFAX is downloaded)	Address Book	—	—	Choose the address of the recipient from the address book.	
	Manual	—	—	Manually enter the address of the recipient.	
	OK	Options	(For details, see the <i>Options</i> on page 171.)	Configure the detailed settings.	
		Save as Shortcut	—	Saves the current settings as a shortcut.	

+ See Software and Network User's Guide.

◆ See Advanced User's Guide.

The default settings are shown in Bold with an asterisk.

Level1	Level2	Level3	Options	Descriptions	Page
to FTP	Profile Name	Options	(For details, see the <i>Options</i> on page 172.)	Configure the detailed settings.	See + .
		Save as Shortcut	—	Saves the current settings as a shortcut.	
to Network	Profile Name	Options	(For details, see the <i>Options</i> on page 172.)	Configure the detailed settings.	
		Save as Shortcut	—	Saves the current settings as a shortcut.	
WS Scan (Appears when you install a Web Services Scanner, which is displayed in your computer's Windows® Explorer.)	—	Scan	PC Select	You can scan data by using the Web Services protocol.	
		Scan for E-mail			
		Scan for Fax			
		Scan for Print			
+ See Software and Network User's Guide. ◆ See Advanced User's Guide.					
The default settings are shown in Bold with an asterisk.					

Options

(for to OCR)

Level1	Level2	Options	Descriptions	Page
Options	Set with Touch Panel	Off (Set with Computer)* On	If you want to use the Touchscreen to change the machine's settings, choose On.	See +.
	The settings below will appear when On is selected in Set with Touch Panel.			
	ADF High Speed Mode	On Off*	You can scan A4 or Letter documents faster by placing them long side edge first in the ADF.	93
	Scan Type	Colour Black and White*	You can choose the scan type for your document.	See +.
	Resolution	100 dpi 200 dpi* 300 dpi 600 dpi	You can choose the scan resolution for your document.	
	File Type	Text* HTML RTF	You can choose the file format for your document.	
	Scan Size	A4* A5 A3 10x15cm Business Card (90x60mm) Letter Legal Ledger	You can choose the scan size for your document.	
+ See Software and Network User's Guide.				
The default settings are shown in Bold with an asterisk.				

Options

(for to File, to Image Or to E-mail)

Level1	Level2	Options	Descriptions	Page
Options	Set with Touch Panel	Off (Set with Computer)* On	If you want to use the Touchscreen to change the machine's settings, choose On.	See +.
	The settings below will appear when On is selected in Set with Touch Panel.			
	ADF High Speed Mode	On Off*	You can scan A4 or Letter documents faster by placing them long side edge first in the ADF.	93
	Scan Type	Colour* Black and White	You can choose the scan type for your document.	See +.
	Resolution	100 dpi 200 dpi* 300 dpi 600 dpi	You can choose the scan resolution for your document.	
	File Type	(If you choose the Colour option in the Scan Type setting) PDF* JPEG (If you choose the Mono option in the Scan Type setting) PDF* TIFF	You can choose the file format for your document.	
	Scan Size	A4* A5 A3 10x15cm Business Card (90x60mm) Letter Legal Ledger	You can choose the scan size for your document.	
	Remove Background Colour	Off* Low Medium High	Changes the amount of background colour that is removed.	
+ See Software and Network User's Guide.				
The default settings are shown in Bold with an asterisk.				

Options

(for to Media)

Level1	Level2	Options	Descriptions	Page
Options	ADF High Speed Mode	On Off*	You can scan A4 or Letter documents faster by placing them long side edge first in the ADF.	93
	Scan Type	Colour* Black and White	You can choose the scan type for your document.	83
	Resolution	100 dpi 200 dpi* 300 dpi 600 dpi Auto	You can choose the scan resolution for your document.	
	File Type	(If you choose the Colour option in the Scan Type setting) PDF* JPEG (If you choose the Mono option in the Scan Type setting) PDF* TIFF	You can choose the file format for your document.	
	Scan Size	A4* A5 A3 10x15cm Business Card (90x60mm) Letter Legal Ledger	You can choose the scan size for your document.	
	Scan Long Paper	On Off*	You can scan a long document using the ADF.	
	File Name	—	You can rename the file.	
	Auto Crop	On Off*	Scan multiple documents placed on the scanner glass to a memory card or USB Flash drive one at a time.	83 See ♦.

♦ See Advanced User's Guide.

The default settings are shown in Bold with an asterisk.

Level1	Level2	Options	Descriptions	Page
Options (Continued)	Remove Background Colour	Off* Low Medium High	Change the amount of background colour that is removed.	83
	Set New Default	Yes No	You can save your scan settings as the default settings.	See ♦.
	Factory Reset	Yes No	You can restore all settings to the original factory default settings.	
♦ See Advanced User's Guide.				
The default settings are shown in Bold with an asterisk.				

Options

(for to E-mail Server)

NOTE

It is available after IFAX is downloaded.

Level1	Level2	Options1	Descriptions	Page
Options	ADF High Speed Mode	On Off*	You can scan A4 or Letter documents faster by placing them long side edge first in the ADF.	93
	Scan Type	Colour* Black and White	You can choose the scan type for your document.	See +.
	Resolution	100 dpi 200 dpi* 300 dpi 600 dpi Auto	You can choose the scan resolution for your document.	
	File Type	(If you choose the Colour option in the Scan Type setting) PDF* JPEG (If you choose the Mono option in the Scan Type setting) PDF* TIFF	You can choose the file format for your document.	
+ See Software and Network User's Guide.				
The default settings are shown in Bold with an asterisk.				

Level1	Level2	Options1	Descriptions	Page
Options (Continued)	Scan Size	A4* A5 A3 10x15cm Business Card (90x60mm) Letter Legal Ledger	You can choose the scan size for your document.	See +.
	Scan Long Paper	On Off*	You can scan a long document using the ADF.	
	Set New Default	Yes No	You can save your scan settings as the default settings.	
	Factory Reset	Yes No	You can restore all settings to the original factory default settings.	
+ See Software and Network User's Guide.				
The default settings are shown in Bold with an asterisk.				

Options

(for to **FTP** or to **Network**)

Level1	Level2	Options1	Descriptions	Page
Options	ADF High Speed Mode	On Off*	You can scan A4 or Letter documents faster by placing them long side edge first in the ADF.	93
	Scan Type	Colour* Black and White	You can choose the scan type for your document.	See +.
	Resolution	100 dpi 200 dpi* 300 dpi 600 dpi Auto	You can choose the scan resolution for your document.	
+ See Software and Network User's Guide.				
The default settings are shown in Bold with an asterisk.				

Level1	Level2	Options1	Descriptions	Page
Options (Continued)	File Type	(If you choose the Colour option in the Scan Type setting) PDF* JPEG (If you choose the Mono option in the Scan Type setting) PDF* TIFF	You can choose the file format for your document.	See +.
	Scan Size	A4* A5 A3 10x15cm Business Card (90x60mm) Letter Legal Ledger	You can choose the scan size for your document.	
	Scan Long Paper	On Off*	You can scan a long document using the ADF.	
	File Name	BRNXXXXXXXXXXXXX* Estimate Report Order sheet Contract sheet Check Receipt <Manual>	Choose preset file names. If you choose Manual, you can name the file as you like.	
	Remove Background Colour	Off* Low Medium High	Change the amount of background colour that is removed.	
	User Name	—	Enter the user name.	
+ See Software and Network User's Guide.				
The default settings are shown in Bold with an asterisk.				



Photo



Level1	Level2	Level3	Options	Descriptions	Page
Index Print	Print Index Sheet	Print Settings	For more information, see the <i>Print Settings</i> on page 178.	You can print a thumbnail page.	See ♦.
	Print Photos	Print Settings	For more information, see the <i>Print Settings</i> on page 176.	You can print an individual image.	
View Photos*	OK	Print Settings	For more information, see the <i>Print Settings</i> on page 176.	You can adjust your photos with the options.	82
	Print All	—	—	You can print all photos in your memory card or USB Flash drive.	
Enhance Photos	Enhance	Auto Correct	Print Settings (For more information, see the <i>Print Settings</i> on page 176.)	You can adjust and crop your photos with these settings.	See ♦.
		Enhance Skin			
		Enhance Scenery			
		Remove Red-Eye			
		Night Scene			
		Fill Light			
		Whiteboard			
		Monochrome			
		Sepia			
	Auto Correct & Remove Red-Eye				
Crop	Print Settings	For more information, see the <i>Print Settings</i> on page 176.	You can crop your photo and print a part of the image.		
♦ See Advanced User's Guide.					
The default settings are shown in Bold with an asterisk.					

Level1	Level2	Level3	Options	Descriptions	Page
ID Photo Print	Select a Photo	Select ID Photo Size (Options) 25x36mm 35x45mm 36x51mm 45x45mm 45x55mm 35x48mm 50x70mm (2x2.75in) 2x2inch	Print Settings (For more information, see the <i>Print Settings</i> on page 179.)	You can print ID photos for your resume, passport and so on.	See ◆ .
Slide Show	Show Each Photo for	3Secs* 10Secs 30Secs 1Min 5Mins	—	Sets the time each photo in the Slide Show is shown before the machine switches to the next photo.	
	Start	—	—	The machine starts a Slide Show of your photos. You can choose a photo during the Slide Show and change the print settings. (For more information, see the <i>Print Settings</i> on page 176.)	
◆ See Advanced User's Guide.					
The default settings are shown in Bold with an asterisk.					

Print Settings

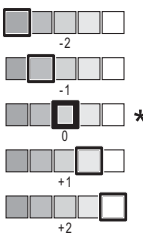
(for View Photos, Print Photos, Enhance Photos Or Slide Show)

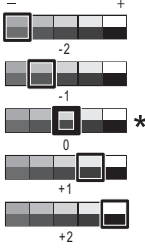
Option1	Option2	Option3	Option4	Descriptions	Page
Print Quality (Not available for DPOF printing.)	Normal Photo*	—	—	Choose the print quality.	See ◆.
Paper Type	Plain Paper Inkjet Paper Brother BP71 Other Glossy*	—	—	Choose the paper type.	
Paper Size	10x15cm* 13x18cm A4 A3 Letter Ledger	—	—	Choose the paper size.	
(When A4 or Letter is chosen) Print Size	8x10cm 9x13cm 10x15cm 13x18cm 15x20cm Max. Size*	—	—	Choose the print size if you are using A4 or Letter size paper.	
Auto Correct (Does not appear when DPOF Print is chosen.) (View Photos and Slide Show only)	On Off*	—	—	The machine decides the appropriate effect for your photo.	
Brightness (Does not appear when Enhance is chosen.)		—	—	Adjusts the brightness.	
◆ See Advanced User's Guide.					
The default settings are shown in Bold with an asterisk.					

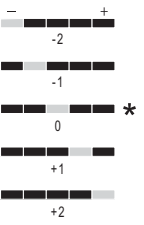
Option1	Option2	Option3	Option4	Descriptions	Page
Contrast (Does not appear when Enhance is chosen.)		—	—	Adjusts the contrast.	See ♦.
Colour Enhance (Does not appear when Enhance is chosen.)	Colour Enhance (Options) On Off*	White Balance		Adjusts the hue of the white areas.	
		Sharpness		Enhances the detail of the image.	
		Colour Density		Adjusts the total amount of colour in the image.	
Cropping	On* Off	—	—	Crops the image around the margin to fit the paper size or print size. Turn this feature off if you want to print whole images or prevent unwanted cropping.	
Borderless	On* Off	—	—	Expands the printable area to fit the edges of the paper.	
Date Print (Not available for DPOF printing.)	On Off*	—	—	Prints the date on your photo.	
Set New Default	Yes No	—	—	Saves your print settings as the default settings.	
♦ See Advanced User's Guide.					
The default settings are shown in Bold with an asterisk.					

Option1	Option2	Option3	Option4	Descriptions	Page
Factory Reset	Yes No	—	—	Restores all the settings back to the factory default.	See ◆.
◆ See Advanced User's Guide.					
The default settings are shown in Bold with an asterisk.					

Print Settings

(for Print Index Sheet)

Level1	Level2	Level3	Options	Descriptions	Page
Paper Type	Plain Paper* Inkjet Paper Brother BP71 Other Glossy	—	—	Choose the paper type.	See ◆.
Paper Size	Letter A4*	—	—	Choose the paper size.	
◆ See Advanced User's Guide.					
The default settings are shown in Bold with an asterisk.					

Print Settings

(for ID Photo Print)

Level1	Level2	Level3	Options	Descriptions	Page
Print Quality	Normal Photo*	—	—	Choose the print quality.	See ◆.
Paper Type	Plain Paper Inkjet Paper Brother BP71 Other Glossy*	—	—	Choose the paper type.	
Paper Size	10x15cm* 13x18cm A4 Letter	—	—	Choose the paper size.	
Photo Enhance	Off* Auto Correct Remove Red-Eye Auto Correct & Remove Red-Eye	—	—	You can adjust your photos with these settings.	
◆ See Advanced User's Guide.					
The default settings are shown in Bold with an asterisk.					





Web

Level1	Level2	Level3	Options	Descriptions	Page
Web	Apps	—	—	Lets you connect the Brother machine to an Internet service. Web services may have been added and/or service names may have been changed by the provider since this document was published.	See ●.
	SkyDrive®	—	—		
	Box	—	—		
	Google Drive™	—	—		
	Evernote®	—	—		
	Dropbox	—	—		
	Facebook	—	—		
	Picasa Web Albums™	—	—		
Flickr®	—	—	—		
● Please go to the Brother Solutions Center to download Web Connect Guide at http://solutions.brother.com/ .					
The default settings are shown in Bold with an asterisk.					

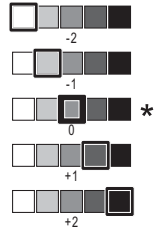

A3 Copy Shortcuts

Level1	Level2	Option1	Option2	Descriptions	Page
A3 2in1 A3* A4 → A3 A3→A4 A4 + Note (L) A4 + Note (P) A4 + Grid A4 + Blank A4 Centre	Options	Quality	Normal* Best	Choose the Copy resolution for the next copy.	See ◆.
		Paper Type	Plain Paper	Displays the available paper type.	
		Paper Size	A3* Ledger (When A3 → A4 is chosen) A4* Letter	Sets the size of paper in the paper tray.	
		Tray Select (MFC-J6720DW)	Auto Tray Select	Automatically chooses the tray that contains the most suitable paper.	
		Density		Adjusts the density of copies.	
		Auto Deskew	Auto* Off	If your scanned copy is skewed, your machine can correct the data automatically.	
◆ See Advanced User's Guide.					
The default settings are shown in Bold with an asterisk.					

 (Shortcuts)

Level1	Level2	Level3	Options	Descriptions	Page
Add Shortcut	Copy	ADF HighSpeed Mode	For more information, see <i>Options in Copy</i> on page 162.	You can change the settings in the Copy Options.	12
		Quality			
		Paper Type			
		Paper Size			
		Tray Select (MFC-J6720DW)			
		Enlarge/Reduce			
		Density			
		Stack/Sort			
		Page Layout			
		Auto Deskew			
		2-sided Copy			
		Advanced Settings			
		The default settings are shown in Bold with an asterisk.			

Level1	Level2	Level3	Options	Descriptions	Page
Add Shortcut (Continued)	Fax (Options)	Fax Resolution	Standard* Fine S.Fine Photo	Sets the resolution for outgoing faxes.	13
		Contrast	Auto* Light Dark	Changes the brightness of faxes you send.	
		Glass Scan Size	A4* A3 Letter Legal Ledger	Adjusts the scan area of the scanner glass to the size of the document.	
		Broadcasting	Add Number (Options) Add Number Add from Address book Search in Address book	You can send the same fax message to more than one fax number.	
		Preview	On Off*	You can preview a fax message before you send it.	
		Colour Setting	Mono* Colour	Sets whether faxes are sent in monochrome or colour.	
		Real Time TX	On Off*	You can send a fax without using the memory.	
		Overseas Mode	On Off*	If you are having difficulty sending faxes overseas, set this to On.	
		Call History	Outgoing Call	You can choose a number from the Outgoing Call history.	
			Caller ID history	You can choose a number from the Caller ID history.	
		Address Book	—	You can choose a number from the Address Book.	

The default settings are shown in Bold with an asterisk.

Level1	Level2	Level3	Options	Descriptions	Page
Add Shortcut (Continued)	Scan	to File	PC Select	You can scan a monochrome or a colour document into your computer.	14
		to OCR	PC Select	You can have your text document converted to an editable text file.	
		to Image	PC Select	You can scan a colour picture into your graphics application.	
		to Media (Options)	ADF High Speed Mode Scan Type Resolution File Type Scan Size Scan Long Paper File Name Auto Crop Remove Background Colour	You can scan documents into a memory card or USB Flash drive.	
		to E-mail	PC Select	You can scan a monochrome or a colour document into your E-mail application.	
		to E-mail Server (Options)	ADF High Speed Mode Scan Type Resolution File Type Scan Size Scan Long Paper	You can scan a monochrome or a colour document into your E-mail Server.	
		to Network	Profile Name	You can send scanned data to a CIFS server on your local network or on the Internet.	
		to FTP	Profile Name	You can send scanned data via FTP.	
The default settings are shown in Bold with an asterisk.					

Level1	Level2	Level3	Options	Descriptions	Page
Add Shortcut (Continued)	Web	SkyDrive®	—	Lets you connect the Brother machine to an Internet service. Web services may have been added and/or service names may have been changed by the provider since this document was published.	15
		Box	—		
		Google Drive™	—		
		Evernote®	—		
		Dropbox	—		
		Facebook	—		
		Picasa Web Albums™	—		
	Flickr®	—			
This list appears when each Shortcut name is pressed for 2 seconds.	Edit Shortcut Name	—	—	You can change the shortcut name.	17
	Delete	—	—	Deletes the shortcut.	17
Edit/Delete	Shortcut Name	Edit Shortcut Name	—	You can change the shortcut name.	17
		Delete	—	Deletes the shortcut.	17

The default settings are shown in Bold with an asterisk.

 (Ink)

Level1	Level2	Level3	Options	Descriptions	Page
 (Ink)	Test Print	—	Print Quality Alignment	Lets you check the print quality or alignment.	98 100
	Cleaning	—	Black Colour All	Lets you clean the print head.	98
	Ink Volume	—	—	Lets you check the available ink volume.	See ♦.

♦ See Advanced User's Guide.

The default settings are shown in Bold with an asterisk.

WiFi (Wi-Fi Setup)

NOTE

After the Wi-Fi® is set up, you cannot change the settings from your Home screen. Change any settings for the Wi-Fi connection in the Settings screen.

Level1	Level2	Level3	Options	Descriptions	Page
WiFi (Wi-Fi Setup)	Setup Wizard	—	—	You can manually configure your print server for a wireless network.	See ‡.
	Setup with PC	—	—	You can configure the Wi-Fi settings using a PC.	
	WPS/AOSS	—	—	You can easily configure your wireless network settings using the one-button push method.	
	WPS w/ PIN Code	—	—	You can easily configure your wireless network settings using WPS with a PIN.	See †.
‡ See Quick Setup Guide.					
† See Software and Network User's Guide.					
The default settings are shown in Bold with an asterisk.					

When using memory cards or USB Flash drive in the correct slot

Level1	Level2	Level3	Options	Descriptions	Page
Photo	(See <i>Photo</i> on page 174.)				
Scan to Media	(See <i>to Media</i> on page 166.)				
Web	(See <i>Web</i> on page 179.)				
DPOF	—	—	—	Displays the DPOF setting screen.	See ◆.
◆ See Advanced User's Guide.					
The default settings are shown in Bold with an asterisk.					

Entering Text

When you need to enter text into the machine the keyboard will appear on the Touchscreen.

Press  to cycle between letters, numbers and special characters.

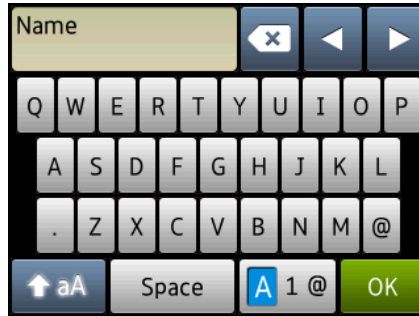

NOTE

- To change between lowercase or uppercase, press .
- You can change the keyboard setting of the Touchscreen.
(For more information, see *Changing the keyboard setting* on page 12.)



Inserting spaces



To enter a space, press `Space`. Or, you can press  to move the cursor.

NOTE

The characters that are available may differ depending on your country.

Making corrections

If you entered an incorrect character and want to change it, press  to move the cursor to highlight the incorrect character, and then press . Enter the correct character. You can also use the cursor to go back and insert letters.

Press  for each character you want to erase, or press and hold  to erase all the characters.

General

NOTE

This chapter provides a summary of the machines' specifications. For additional specifications visit <http://www.brother.com/>.

Printer Type	Inkjet	
Print Head	Mono:	Piezo with 420 nozzles × 1
	Colour:	Piezo with 420 nozzles × 3
Memory Capacity	128 MB	
LCD (Liquid Crystal Display)	2.7 in. (67.5 mm) TFT Colour Touchscreen LCD ¹ and Touchpanel	
Power Source	AC 220 to 240V 50/60Hz	
Power Consumption ²	Copying Mode:	Approx. 28 W ³
	Ready Mode:	Approx. 5.5 W ⁴
	Sleep Mode:	Approx. 1.5 W ⁴
	Off:	Approx. 0.04 W ^{4 5}

¹ Measured diagonally.

² Measured when the machine is connected to the USB interface. Power consumption varies slightly depending on the usage environment or part wear.

³ When using ADF, single-sided printing, resolution: standard / document: ISO/IEC 24712 printed pattern.

⁴ Measured according to IEC 62301 Edition 2.0.

⁵ Even when the machine is turned off, it will automatically turn itself on periodically for print head maintenance, and then turn itself off.

Dimensions

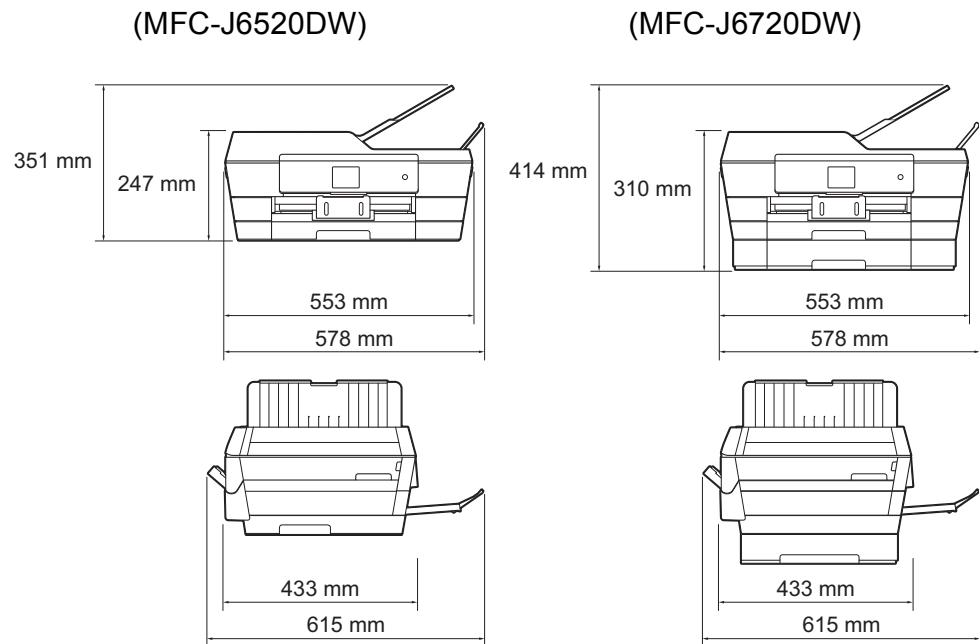

Weight

(MFC-J6520DW) 14.5 kg

(MFC-J6720DW) 16.7 kg

Noise Level

Sound Pressure

Operating: $L_{pAm} = 50 \text{ dB(A)}$ (Maximum) ¹

Sound Power ^{2 3}

Copying ⁴: $L_{WAd} = 6.33 \text{ B(A)}$ (Mono)

$L_{WAd} = 6.25 \text{ B(A)}$ (Colour)

Ready: $L_{WAd} = 3.01 \text{ B(A)}$ (Mono/Colour)

Temperature

Operating: 10 to 35 °C

Best Print Quality: 20 to 33 °C

Humidity

Operating: 20 to 80% (without condensation)

Best Print Quality: 20 to 80% (without condensation)

ADF (automatic document feeder)

Up to 35 pages

Paper: 80 g/m² A4 or Letter size

Document Size

ADF Width: 148 mm to 297 mm

ADF Length: 148 mm to 431.8 mm

Scanner Glass Width: Max. 297 mm

Scanner Glass Length: Max. 431.8 mm

¹ Noise depends on printing conditions.

² In accordance with ISO9296

³ Office equipment with $L_{WAd} > 6.30 \text{ B(A)}$ is not suitable for use in room where people require high levels of concentration. Such equipment should be placed in separate rooms because of the noise emission.

⁴ Copy speed: 14 cpm (Mono) / 11 cpm (Colour)
These copy speeds were measured in the manner of 3.5.1 of RAL-UZ171.

Print media

Paper Input

Paper Tray #1

- Paper type:
 - Plain paper, inkjet paper (coated paper), glossy paper¹ and transparency^{1 2}
- Paper size³:
 - (Landscape)
 - A4, Letter, Executive
 - (Portrait)
 - A3, Ledger, Legal, Folio, A5, A6, Envelopes (C5, Com-10, DL, Monarch), Photo (10 × 15 cm), Photo L (89 × 127 mm), Photo 2L (13 × 18 cm) and Index card (127 × 203 mm)
 - Width: 89 mm - 297 mm
 - Length: 127 mm - 431.8 mm
 - For more details, see *Paper weight and thickness* on page 43.
- Maximum paper tray capacity:
 - Approx. 250 sheets of 80 g/m² plain paper

Paper Tray #2 (MFC-J6720DW)

- Paper type:
 - Plain Paper
- Paper size:
 - (Landscape)
 - A4, Letter
 - (Portrait)
 - A3, Ledger, Legal
 - Width: 210 mm - 297 mm
 - Length: 279.4 mm - 431.8 mm
 - For more details, see *Paper weight and thickness* on page 43.
- Maximum paper tray capacity:
 - Approx. 250 sheets of 80 g/m² plain paper

¹ For glossy paper or transparencies, remove printed pages from the output paper tray immediately after they exit the machine to avoid smudging.

² Use only transparency paper recommended for inkjet printing.

³ See *Paper type and size for each operation* on page 41.

Paper Input

(Continued)

Manual Feed Slot

■ Paper type:

Plain paper, inkjet paper (coated paper), glossy paper ¹, transparency ^{1 2} and Envelopes

■ Paper size ³:

(Landscape)

A4, Letter, Executive

(Portrait)

A3, Ledger, Legal, Folio, A5, A6, Envelopes (C5, Com-10, DL, Monarch), Photo (10 × 15 cm), Photo L (89 × 127 mm), Photo 2L (13 × 18 cm) and Index card (127 × 203 mm)

Width: 89 mm - 297 mm

Length: 127 mm - 431.8 mm

For more details, see *Paper weight and thickness* on page 43.

■ Maximum paper tray capacity:

1 sheet of special print media

Paper Output

Up to 50 sheets of 80 g/m² plain paper (face up print delivery to the output paper tray) ¹

¹ For glossy paper or transparencies, remove printed pages from the output paper tray immediately after they exit the machine to avoid smudging.

² Use only transparency paper recommended for inkjet printing.

³ See *Paper type and size for each operation* on page 41.

Fax

Compatibility	ITU-T Super Group 3
Modem Speed	Automatic Fallback 33,600 bps
Scanning Width	288 mm (A3) Scanner Glass: 204 mm (A4)
Printing Width	291 mm (A3)
Greyscale	Monochrome: 8 bit (256 levels) Colour: 24 bit (8 bit per colour/ 256 levels)
Resolution	Standard 203 × 98 dpi (Mono) 203 × 196 dpi (Colour) Fine 203 × 196 dpi (Mono/Colour) Superfine 203 × 392 dpi (Mono) Photo 203 × 196 dpi (Mono)
Address Book	100 names × 2 numbers or E-mail addresses ¹
Groups	Up to 6
Broadcasting	250 (200 Address Book/50 Manual Dial)
Automatic Redial	3 times at 5 minute intervals
Memory Transmission	Up to 200 ² pages
Out of Paper Reception	Up to 200 ² pages

¹ E-mail addresses are available after IFAX is downloaded.

² "Pages" refers to the "ITU-T Test Chart #1" (a typical business letter, Standard resolution, MMR code). Specifications and printed materials are subject to change without prior notice.

Copy

Colour/Monochrome	Yes/Yes
Copy Width	291 mm ¹
Multiple Copies	Stacks/Sorts up to 99 pages
Enlarge/Reduce	25% to 400% (in increments of 1%)
Resolution	Prints up to 1200 × 2400 dpi
2-sided	Yes
	■ Paper type: Plain paper
	■ Paper size: A4, Letter, Ledger, A3, Legal, A5

¹ When copying on A3 size paper.

PhotoCapture Center™

Compatible Media ¹	<p>Memory Stick Duo™ (16 MB - 128 MB) Memory Stick PRO Duo™ (256 MB - 32 GB) Memory Stick Micro™ (M2™) with Adapter (256 MB - 32 GB) MultiMedia Card (32 MB - 2 GB) MultiMedia Card plus (128 MB - 4 GB) MultiMedia Card mobile with Adapter (64 MB - 1 GB) SD Memory Card (16 MB - 2 GB) miniSD with Adapter (16 MB - 2 GB) microSD with Adapter (16 MB - 2 GB) SDHC Memory Card (4 GB - 32 GB) miniSDHC with Adapter (4 GB - 32 GB) microSDHC with Adapter (4 GB - 32 GB) SDXC Memory Card (48 GB - 128 GB) USB Flash drive ²</p>
Resolution	Up to 1200 × 4800 dpi
File Extension (Media Format) (Image Format)	<p>DPOF (ver. 1.0, ver. 1.1), Exif DCF (up to ver. 2.1) Photo Print: JPEG ³, AVI ⁴, MOV ⁴ Scan to Media: JPEG, PDF (Colour) TIFF, PDF (Monochrome)</p>
Number of Files	<p>Up to 999 files (Folders inside memory cards or USB Flash drives are also counted as files.)</p>
Folder	Files can be stored up to 4 folder levels deep on the memory card or USB Flash drive.
Borderless	A4, Letter, Ledger, A3, Photo (10 × 15 cm), Photo 2L (13 × 18 cm) ⁵

¹ Memory cards, adapters and USB Flash drives are not included.

² USB 2.0 Standard
 USB Mass Storage standard up to 64 GB
 Support format: FAT12/FAT16/FAT32/exFAT

³ Progressive JPEG format is not supported.

⁴ Motion JPEG only

⁵ See *Paper type and size for each operation* on page 41.

PictBridge

Compatibility

Supports the Camera & Imaging Products Association PictBridge standard CIPA DC-001.

Visit <http://www.cipa.jp/pictbridge/> for more information.

Interface

USB direct interface

Scanner

Colour/Monochrome	Yes/Yes
TWAIN Compliant	Yes (Windows® XP ¹ /Windows Vista®/Windows® 7/Windows® 8) (Mac OS X v10.6.8, 10.7.x, 10.8.x)
WIA Compliant	Yes (Windows® XP ¹ /Windows Vista®/Windows® 7/Windows® 8)
ICA Compliant	Yes (Mac OS X v10.6.8, 10.7.x, 10.8.x)
Colour Depth	48 bit colour Processing (Input) 24 bit colour Processing (Output) / 256 levels per colour
Greyscale	16 bit colour Processing (Input) 8 bit colour Processing (Output) / 256 levels per colour
Resolution	Up to 19200 × 19200 dpi (interpolated) ² Up to 2400 × 2400 dpi (optical) (Scanner Glass) Up to 2400 × 1200 dpi (optical) (ADF)
Scanning Width and Length	Width: Up to 293 mm Length: Up to 427.8 mm

¹ Windows® XP in this User's Guide includes Windows® XP Home Edition, Windows® XP Professional, and Windows® XP Professional x64 Edition.

² Maximum 1200 × 1200 dpi scanning when using the WIA Driver for Windows® XP, Windows Vista®, Windows® 7 and Windows® 8 (resolution up to 19200 × 19200 dpi can be selected by using the Brother scanner utility).

Printer

Resolution

Up to 1200 × 6000 dpi

Printing Width ³

291 mm [297 mm (borderless) ¹]

Borderless ²

A4, Letter, Ledger, A3, A6, Photo (10 × 15 cm),
Photo L (89 × 127 mm), Photo 2L (13 × 18 cm),
Index Card (127 × 203 mm)

2-sided**■ Paper type:**

Plain paper

■ Paper size:

A4, Letter, A3, Ledger, Legal, Folio, A5, Executive

Print Speed ⁴

¹ When the Borderless feature is set to On.

² See *Paper type and size for each operation* on page 41.

³ When printing on A3 size paper.

⁴ For detailed specifications visit <http://www.brother.com/>.

Interfaces

USB ^{1 2}	A USB 2.0 interface cable that is no longer than 5 m.
LAN cable ³	Ethernet UTP cable category 5 or greater.
Wireless LAN	IEEE 802.11b/g/n (Infrastructure/Ad-hoc Mode) IEEE 802.11g/n (Wi-Fi Direct™)

¹ Your machine has a Hi-Speed USB 2.0 interface. The machine can also be connected to a computer that has a USB 1.1 interface.

² Third party USB ports are not supported.

³ See *Network* on page 198.
See Software and Network User's Guide.

Network

NOTE

For more information about the Network specifications, see Software and Network User's Guide.

You can connect your machine to a network for Network Printing, Network Scanning, PC Fax Send, PC Fax Receive (Windows® only), Remote Setup, and to access photos from PhotoCapture Center™¹. Also included is the Brother BRAdmin Light² Network Management software.

Wireless Network Security	SSID (32 characters), WEP 64/128 bit, WPA-PSK (TKIP/AES), WPA2-PSK (AES)
Wireless Setup Support Utility	AOSS™ Yes WPS Yes

¹ See *Computer requirements* on page 199.

² (Windows®) If you require more advanced printer management, use the latest Brother BRAdmin Professional utility version that is available as a download from <http://solutions.brother.com/>.
(Macintosh) The latest Brother BRAdmin Light is available as a download from <http://solutions.brother.com/>.

Computer requirements

SUPPORTED OPERATING SYSTEMS AND SOFTWARE FUNCTIONS							
Computer Platform & Operating System Version		PC Interface			Processor	Hard Disk Space to install	
		USB ²	10/100 Base-TX (Ethernet)	Wireless 802.11b/g/n		For Drivers	For Applications (including Drivers)
Windows® Operating System	Windows® XP Home ^{1 4}	Printing PC Fax ³ Scanning Removable Disk (USB or Memory card) ⁵ Network Media Access (LAN) ⁵			32bit (x86) or 64bit (x64) processor	150 MB	1 GB
	Windows® XP Professional ^{1 4}						
	Windows Vista® ^{1 4}					500 MB	1.3 GB
	Windows® 7 ^{1 4} Windows® 8 ^{1 4}					650 MB	
	Windows Server® 2003	N/A	Printing			50 MB	N/A
	Windows Server® 2003 R2						
	Windows Server® 2008						
	Windows Server® 2008 R2				64bit (x64) processor		
Windows Server® 2012							
Macintosh Operating System	Mac OS X v10.6.8 OS X v10.7.x OS X v10.8.x	Printing PC Fax (Send) ³ Scanning Removable Disk (USB or Memory card) ⁵ Network Media Access (LAN) ⁵			Intel® Processor	80 MB	550 MB

Conditions:

- ¹ For WIA, 1200 × 1200 resolution. Brother Scanner Utility enables to enhance up to 19200 × 19200 dpi.
- ² Third party USB ports are not supported.
- ³ PC Fax supports black and white only.
- ⁴ PaperPort™ 12SE supports Windows® XP Home (SP3 or greater), XP Professional (SP3 or greater), XP Professional x64 Edition (SP2 or greater), Windows Vista® (SP2 or greater), Windows® 7 and Windows® 8.
- ⁵ Removable disk and Network Media Access are functions of PhotoCapture Center™.

For the latest driver updates, visit us at <http://solutions.brother.com/>.

All trademarks, brand and product names are the property of their respective companies.

Consumable items

Ink	The machine uses individual Black, Yellow, Cyan and Magenta ink cartridges that are separate from the print head assembly.
Service Life of Ink Cartridge	The first time you install a set of ink cartridges the machine will use an amount of ink to fill the ink delivery tubes for high quality printouts. This process will only happen once. After this process is complete the cartridges provided with your machine will have a lower yield than regular capacity cartridges (65 %). With all following ink cartridges you can print the specified number of pages.
Replacement Consumables	<p><Super High Yield Black> LC129XLBK <Super High Yield Yellow> LC125XLY <Super High Yield Cyan> LC125XLC <Super High Yield Magenta> LC125XLM</p> <p>Black - Approximately 2,400 pages ¹ Yellow, Cyan and Magenta - Approximately 1,200 pages ¹</p> <p><High Yield Black> LC123BK <High Yield Yellow> LC123Y <High Yield Cyan> LC123C <High Yield Magenta> LC123M</p> <p>Black, Yellow, Cyan and Magenta - Approximately 600 pages ¹</p> <p>¹ Approx. cartridge yield is declared in accordance with ISO/IEC 24711.</p> <p>For more information about the replacement consumables, visit us at http://www.brother.com/pageyield/.</p>

What is Innobella™?

Innobella™ is a range of genuine consumables offered by Brother. The name "Innobella™" derives from the words "Innovation" and "Bella" (meaning "Beautiful" in Italian) and is a representation of the "innovative" technology providing you with "beautiful" and "long lasting" print results.

When you print photo images, Brother recommends Innobella™ glossy photo paper (BP71 series) for high quality. Brilliant prints are made easier with Innobella™ Ink and paper.



A

Address Book	
changing	75
deleting	75
Group dial	
changing	75
setting up	74
using	71
ADF (automatic document feeder)	44
Answering machine (TAD)	66
connecting	66
Apple Macintosh	
See Software and Network User's Guide.	
Automatic	
fax receive	52
Fax Detect	56

B

Brother	
CreativeCenter	4

C

Caller ID	63
Caller ID history	73
Add to Address Book	73
Delete	73
Send a fax	73
Cleaning	
print head	98
scanner	97
Connecting	
external TAD (answering machine)	66
external telephone	67
Consumable items	200
Control panel overview	6
ControlCenter	
See Software and Network User's Guide.	
Copy	
paper size	77
paper type	77
Shortcuts	12
tray use	38
using scanner glass	45

Custom telephone features on a single line	131
--	-----

D

Dialling	
a pause	74
Address Book	71
Caller ID history	73
manual	71
Outgoing Call	72
Document	
loading	44, 45

E

Envelopes	25, 27, 33, 41, 43
Error messages on Touchscreen	104
B&W 1-sided Print Only	104
Cannot Detect	105
Cannot Print	105
Comm. Error	105
Cover is Open	105
Data Remaining in Memory	105
Document Jam/too Long	106
Ink Absorber Full	107
Ink Absorber NearFull	107
Ink Low	107
No Ink Cartridge	108
No Paper Fed	109
Out of Fax Memory	109
Out of Memory	110
Paper Jam	110
Unable to Clean	112
Unable to Initialize	112
Unable to Print	112
Unable to Scan	112
Wrong Paper	113
Wrong Tray Setting	113
Extension telephone, using	68, 69
External telephone, connecting	67

F

- FAX (PC-FAX)
 - Windows®
 - sending60
- Fax codes
 - changing69
 - Remote Activation Code 56, 68, 69
 - Remote Deactivation Code 68, 69
 - using69
- Fax Detect56
- Fax, from PC
 - See Software and Network User's Guide.
- Fax, stand-alone
 - receiving52
 - difficulties 128, 129
 - F/T Ring Time, setting55
 - Fax Detect56
 - Fax Preview57
 - from extension telephone 68, 69
 - into PC61
 - Ring Delay, setting55
 - telephone line interference / VoIP 135
 - tray use39
 - sending47
 - change scanner glass size49
 - colour fax49
 - difficulties 130
 - Fax Preview50
 - Shortcuts 12, 13
 - telephone line interference / VoIP 135
 - Transmission Verification Report 51
- Fax/Tel mode
 - answering at extension
 - telephones 68, 69
 - Remote Activation Code 68, 69
 - Remote Deactivation Code 68, 69
 - Ring Delay55

G

- Greyscale 191, 195

H

- Help
 - Features tables 158
 - Settings tables 139
 - Touchscreen messages 138

I

- Ink cartridges
 - ink dot counter 94
 - replacing 94
- Innobella™ 200

J

- Jacks
 - EXT
 - External telephone 67
- Jams
 - document 115
 - paper 117

L

- LCD (Liquid Crystal Display) 6, 138
 - Brightness 19

M

- Macintosh
 - See Software and Network User's Guide.
- Maintenance, routine
 - replacing ink cartridges 94
- Manual
 - dialling 71
 - receive 52
- Manual feed slot 33
- Multi-line connections (PBX) 67

N

- Network
 - Printing
 - See Software and Network User's Guide.
 - Scanning
 - See Software and Network User's Guide.
- Nuance™ PaperPort™ 12SE
 - See Software and Network User's Guide.
 - Also see Help in the PaperPort™ 12SE application.

O

Outgoing Call	
Add to Address Book	72
Delete	72
Send a fax	72

P

Paper	39, 189, 190
capacity	42
loading	20, 25, 28
loading envelopes	25
loading Photo and Photo L paper	25
printable area	36
size	37
size of document	44
type	37, 41
Photo and Photo L paper	25, 41, 42
PhotoCapture Center™	
from PC	
See Software and Network User's Guide.	
MultiMedia Card	79
Preview photos	82
Scan to Media	
change file name	83
SD Memory Card	79
SDHC Memory Card	79
SDXC Memory Card	79
specifications	193
Presto! PageManager	
See Software and Network User's Guide.	
Also see Help in the Presto! PageManager application.	
Print	
difficulties	123
paper jams	117
printable area	36
resolution	196
specifications	196
Printing	
See Software and Network User's Guide.	

R

Receive Mode	
External TAD	52
Fax Only	52
Fax/Tel	52
Manual	52
Redial/Pause	72
Remote Setup	
See Software and Network User's Guide.	
Resolution	
copy	192
fax	191
print	196
scan	195
Ring Delay, setting	55

S

Scan Shortcuts	12, 14
Scanning	
See Software and Network User's Guide.	
Serial Number	
how to find	See inside front cover
Shortcuts	12
adding	12, 13, 14, 15
changing	16
Shortcut name	17
Copy	12
deleting	17
Fax	13
recalling	17
Scan	14
Web	15
Sockets	
EXT	
External telephone	67
Step-by-step Settings Tables	138

T

TAD (telephone answering device), external	52, 66
connecting	66
Receive Mode	52
recording OGM	67
Telephone line	
connections	66
difficulties	128
interference / VoIP	135
multi-line (PBX)	67
type	64
Text, entering	186
Transferring your faxes or Fax Journal report	114
Transparencies	39, 40, 42, 43, 189, 190
Tray Select	78
Troubleshooting	
document jam	115
error messages on Touchscreen	104
if you are having difficulty	
copying	132
document jam	115
entering data	134
incoming calls	131
Network	133
paper handling	127
PhotoCapture Center™	132
print quality	125
printing	123
printing received faxes	128
receiving faxes	129
scanning	132
software	133
telephone line or connections	128
maintenance messages on Touchscreen	104
paper jam	117

U

Unscannable area	46
------------------------	----

V

Volume, setting	
beeper	18
ring	18
speaker	19

W

Web Shortcuts	12, 15
Windows®	
See Software and Network User's Guide.	
Wireless Network	
See Quick Setup Guide and Software and Network User's Guide.	

brother®

Visit us on the World Wide Web
<http://www.brother.com/>

These machines are approved for use in the country of purchase only. Local Brother companies or their dealers will only support machines purchased in their own countries.



www.brotherearth.com