

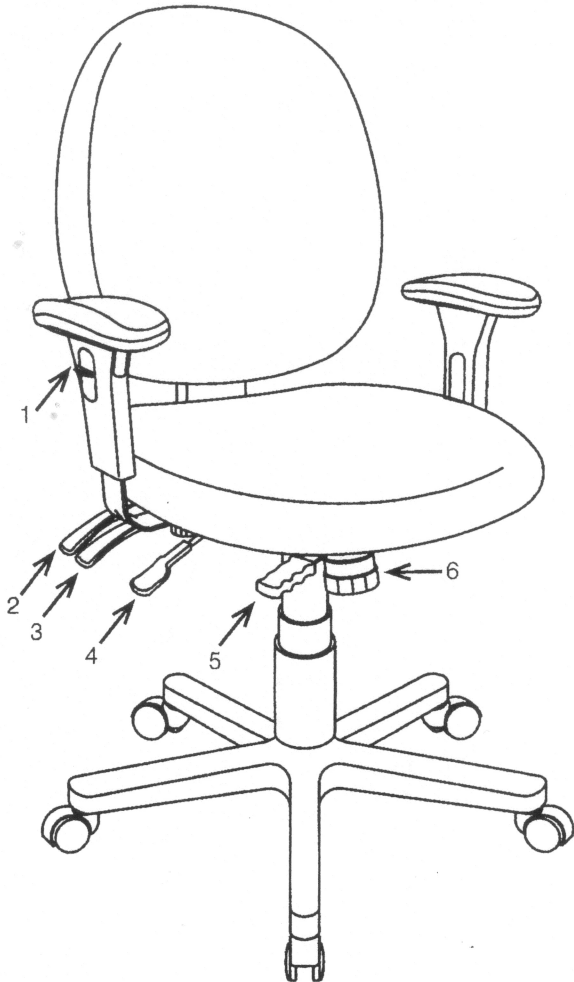

# OPERATING INSTRUCTIONS



## Multi-Function Ergonomic Chair

**LLR60535**  
**LLR60536**  
**LLR60537**  
**LLR60538**

IF YOU ARE MISSING PARTS OR HAVE OTHER CONCERNS PLEASE  
CALL OUR TOLL FREE NUMBER:  
1-888-295-5839 OR EMAIL: [Alex.True@sprich.com](mailto:Alex.True@sprich.com).  
MONDAY-FRIDAY 9:00 AM TO 4:00 P.M. - EASTERN STANDARD TIME

Please provide the following information:

1. Full Name
2. Physical Address - Please do not include a P.O. Box as our carriers cannot deliver to a P.O. Box Address.
3. Phone Number
4. Model Number
5. Part Number
6. Quantity
7. Reason for the request

*Note: Our policy is to send all parts requests with normal ground transportation, if your requirements are to have these parts sent via overnight or next day, please provide your designated carrier and account number.*

### FEATURES

#### • HEIGHT ADJUSTMENT

To raise seat remove pressure from seat and lift lever (4). To lower seat height sit on chair and lift lever (4).

**NOTE:** It is normal for chair to slightly lower under body weight.

#### • SEAT/BACK ANGLE ADJUSTMENT AND FORWARD TILT

To adjust Seat/Back angle, lift lever (3) leave lever up for free float or push lever down to lock. For forward tilt lean back with lever (3) in the down position and push lever (5) forward. Lift lever (3) and the seat will tilt forward for keyboard intensive activities.

#### • ARM HEIGHT ADJUSTMENT

Push button (1) in to allow the arms to move up and down freely release button (1) when desired height is reached.

#### • BACK REST ANGLE ADJUSTMENT

To adjust back angle lift lever (2). Leave lever up for free float or push lever down to lock at any angle.

#### • TENSION ADJUSTMENT

For individual comfort, this chair has been equipped with an adjustment that will allow the user to change the tension of the tilting feature. Turn knob (6) clockwise to increase tension & counter clockwise to decrease or ease tension.

### WARNING

1. Use this product only one person at a time.
2. Do not use this chair unless all bolts, screws, and knobs are securely tightened.
3. Check that all bolts, screws, and knobs are tight every three months or as needed.
4. Do not overturn back tilt knob when decreasing tension.
5. Dispose of packing material properly. Do not use plastic cover as head covering. It may cause suffocation.
6. Do not use chair as a stepladder.
7. Use this chair for its intended purpose only.
8. Use mild detergent only for cleaning.