

# OKI®

# Microline® 420/421

## User's Guide

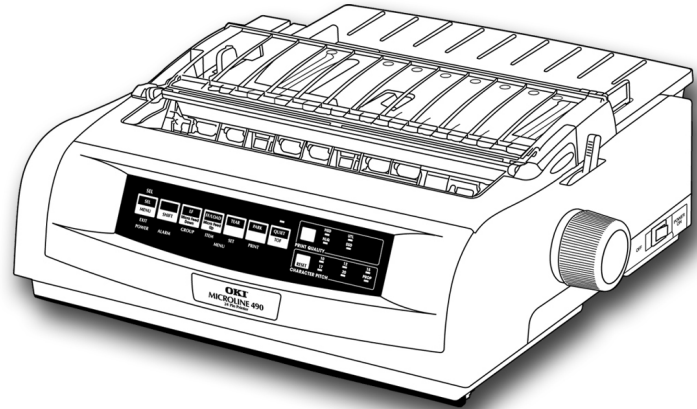

45690301EE Rev1

ML 420/421 User's Guide

P/N 45690301EE, Revision 1

September, 2013

Every effort has been made to ensure that the information in this document is complete, accurate, and up-to-date. Oki Data assumes no responsibility for the results of errors beyond its control. Oki Data also cannot guarantee that changes in software and equipment made by other manufacturers and referred to in this guide will not affect the applicability of the information in it. Mention of software products manufactured by other companies does not necessarily constitute endorsement by Oki Data.

Copyright 2002, 2007 by Oki Data. All rights reserved.

Written and produced by the Oki Data Training and Publications Department.

**Web Site:** <http://www.okiprintingsolutions.com>.

**ENERGY STAR**®



As an ENERGY STAR Partner, Oki Data has determined that this product meets the ENERGY STAR guidelines for energy efficiency.

**Note:** Not comply (when employing Network Interface Card).

### **Trademark Information**

OKI and MICROLINE are registered trademarks of Oki Electric Industry Co., Ltd.

Epson is a registered trademark of Epson America, Inc.

IBM is a registered trademark of International Business Machines Corp.

Microsoft and Windows are either registered trademarks or trademarks of Microsoft Corporation in the United States and other countries.

# Safety

Your Oki printer has been carefully designed to give you years of safe, reliable performance. As with all electrical equipment, there are a few basic precautions you should take to avoid hurting yourself or damaging the printer:

- Carefully read all setup and operating instructions. Be sure to save all documents for future reference.
- Read and follow all warning and instruction labels on the printer itself.
- Place your printer on a firm, solid surface. If you put it on something unsteady, it might fall and be damaged.
- Avoid overheating the printer. Do not place it on a soft surface, such as a rug, sofa, or bed. The vents may be blocked, causing the printer to overheat.
- The printer must be installed near a power outlet which will remain easily accessible.

- Be certain that your power source matches the rating listed on the back of the printer. If you aren't sure, check with your dealer or with your local power company.
- Your printer has a grounded, 3-prong plug as a safety feature. It will only fit into a grounded outlet. If you can not plug it in, chances are that you have an older, non-grounded outlet. Contact an electrician to have it replaced with a grounded outlet. Do not use an adapter to defeat the grounding.
- To avoid damaging the power cord, do not put anything on it or place it where it will be walked on. If the cord becomes damaged or frayed, replace it immediately.
- If you're using an extension cord or power strip with the printer, make sure that the total of the amperes required by all the equipment on the extension is less than the extension's rating. Generally, the total ratings of all equipment plugged into any one power line should not exceed 15 amperes. Don't exceed this unless you know that the power line your equipment is plugged into has a rating above 15 amperes.

- Unplug the printer before you clean it. Use only a damp cloth. Do not use liquid or aerosol cleaners.
- To protect your printer from overheating, make sure no openings on the printer are blocked. Do not put the printer on or near a heat source, such as a radiator or heat register. If you put the printer in any kind of enclosure, make sure it is well ventilated.
- The printhead can get quite hot when it has been printing for a length of time. Do not touch the printhead until it has had a chance to cool off.
- Do not use your printer near water. Do not spill liquid of any kind into it.
- Do not poke anything into the ventilation slots on the sides of the printer. You could get a shock or cause a fire.
- Aside from the routine maintenance described in this document, don't try to service the printer yourself. Opening the cover may expose you to shocks or other hazards. Don't make any adjustments other than those outlined in the document. You might cause damage requiring extensive repair work.

- If anything happens that indicates that your printer is not working properly or has been damaged, unplug it immediately. Then, follow the procedures in “Service and Support” for having your printer serviced.

These are some of the things to look for:

- The power cord or plug is frayed or damaged.
- Liquid has been spilled into the housing, or the printer has been exposed to water.
- The printer has been dropped or its cabinet has been damaged.
- The printer doesn't function normally when you're following the operating instructions.

# Contents

<b>Safety</b> .....	<b>3</b>
<b>Chapter 1: Introduction</b> .....	<b>7</b>
Printer Features .....	7
<b>Chapter 2: Helpful Hints</b> .....	<b>8</b>
Saving Money: Forms Tear-Off .....	8
Saving Time .....	8
Internet Support .....	8
Paper Park .....	8
Operation Tips .....	9
Top of Form (TOF) .....	9
Turning the Platen Knob .....	9
Controlling Access to the Printer .....	9
<b>Chapter 3: Using Your Printer</b> .....	<b>10</b>
Parts Identification: Rear Feed (Continuous Forms) .....	10
Parts Identification: Top Feed (Single Sheets) .....	11

Top of Form (TOF) .....	12
Top of Form (TOF) and Forms Tear-Off .....	12
Determining if Forms Tear-Off is Off or On .....	13
Setting Top of Form (TOF):	
Forms Tear-Off OFF (Default Setting) .....	14
Setting Top of Form (TOF):	
Forms Tear-Off Set to ON .....	15
Temporarily Changing the Top of Form Position .....	16
Resetting Top of Form to the Factory Default .....	16
Forms Tear-Off Feature .....	17
Potential Problems with Software Packages .....	17
Changing the Forms Tear-Off Setting .....	18
Manual Forms Tear Off .....	18
Paper Park .....	18
Changing Paper Paths .....	19
Printhead Gap .....	21
Print Quality .....	22
Character Pitch .....	23
Printer Reset .....	24
Emulations .....	24

<b>Chapter 4: Menu Mode .....</b>	<b>25</b>
Menu Mode Keys .....	25
Entering and Exiting Menu Mode .....	26
Resetting the Menu to the Factory Defaults .....	26
Printing the Menu Settings .....	26
Changing the Menu Settings .....	27
Menu Settings Table .....	28
Explanations of Menu Items .....	35
<b>Chapter 5: Maintenance.....</b>	<b>42</b>
Replacing the Ribbon Cartridge .....	42
Loading Paper .....	44
Rear Feed .....	44
Top Feed (Single Sheets) .....	53
Clearing Paper Jams .....	55
Rear-Feed Paper Jams .....	55
Rear-Feed, Repeating Paper Jams .....	56
Single-Sheet Paper Jams .....	58
Cleaning the Housing .....	59
<b>Chapter 6: Troubleshooting .....</b>	<b>60</b>
General Information .....	60
Problems / Solutions .....	61
<b>Appendix A: Parts &amp; Accessories .....</b>	<b>66</b>
Purchasing Parts & Accessories .....	66
Replacement Parts .....	67
Accessories .....	68

<b>Appendix B: Printer Control Codes .....</b>	<b>69</b>
IBM Proprinter III Commands .....	69
Epson FX Commands .....	72
Oki MICROLINE Standard Commands .....	75
<b>Appendix C: Specifications .....</b>	<b>78</b>
<b>Appendix D: Installation .....</b>	<b>84</b>
Location .....	84
Unpack .....	84
Install the Ribbon Cartridge .....	87
Power Connection .....	88
Computer Connections .....	88
Parallel (LPT): IEEE 1284 .....	88
USB: Specification 1.1 Compliant .....	89
Loading Paper .....	89
Testing the Printer .....	90
Font Sample Test .....	90
Rolling ASCII Test .....	91
Hexadecimal Dump Mode .....	92
Emulations .....	92
Printer Drivers .....	92
Loading the OKI Driver .....	93
Using a Compatible Driver .....	93
<b>Index .....</b>	<b>94</b>

# Chapter 1: Introduction

## Printer Features

- Super reliable, durable operation: 20,000 hours Mean Time Between Failures (MTBF) at 25% duty cycle and 35% page density
- Advanced paper handling, with built-in rear push tractor and zero-tear forms capability.
- Blazing print speeds, in characters per second:
  - **High Speed Draft (HSD) Mode:** 507 cps
  - **Utility Mode:** 380 cps
  - **Near Letter Quality (NLQ) Mode:** 95 cps
  - **Super Speed Draft (SSD) Mode:** 570 cps
- This rugged 9-pin printer can meet the needs of harsh and demanding environments.

## Oki Data on the Internet

The Oki Data Web Sites provide the most current information available on your printer.

On-line documents are available for viewing and downloading via Oki Data's Web Sites.

You may reach Oki Data via the Internet at:

- [www.okidata.com](http://www.okidata.com)
- [my.okidata.com](http://my.okidata.com)

# Chapter 2: Helpful Hints

## Saving Money: Forms Tear-Off

The Forms Tear-Off feature allows a printed continuous forms page to be torn off without wasting paper or adjusting the printer.

When printing stops, Forms Tear-Off automatically moves the paper to align the perforation with the tear bar (located under the access cover), after a time interval which you select through the menu.

Paper remains in the tear-off position until the printer receives more data. Then, the paper moves back down for printing.

*Note: This feature is normally turned off.*

### **Important!**

*Forms Tear-Off and the Top of Form settings interact. For more information, see “Top of Form (TOF) and Forms Tear-Off” in Chapter 3.*

## Saving Time

### Internet Support

Oki Data provides support via the Internet:

- **www.okidata.com** is the main web site, the gateway to Oki Data's products and services.
- **http://my.okidata.com** is a powerful area of Oki Data's web site designed to help you personalize the information and service you get from Oki Data.

### Paper Park

Your printer's paper park feature allows you to print a single sheet (cut-sheet) page without removing continuous feed paper from the printer.

For more information, see “Paper Park” in Chapter 3.



# Operation Tips

## Top of Form (TOF)

Top of Form (TOF) sets the print start position. The factory default is 1" from the top.

The Top of Form can be changed in increments of 1/180", either for a single print job or set to a new default. The overall amount of adjustment is limited to avoid paper jams.

The first line prints at the red line of the plastic paper shield (1) on the printhead.

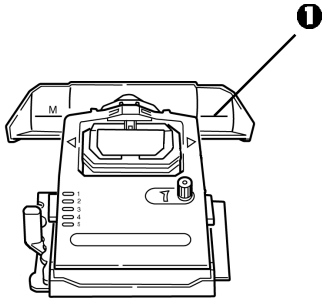

For more information, see “Top of Form (TOF)” in Chapter 3.

## Turning the Platen Knob

### Important!

*Always turn the printer off before turning the platen knob! If you turn the platen knob when the printer is on, the Top of Form misaligns.*

## Controlling Access to the Printer

You can control access to the printer by changing the setting for the Operator Panel Function in the Menu from Full Operation (the factory default) to Limited Operation.

When Limited Operation is selected, the **PRINT QUALITY** and **CHARACTER PITCH** keys don't work. This prevents these settings from being changed from the control panel when several people are using the printer.

For more information, see “Changing the Menu Settings” in Chapter 3.

# Chapter 3: Using Your Printer

## Parts Identification: Rear Feed (Continuous Forms)

*Note: The serial number of your printer is on a label on the back, beside "S/N."*

- ❶ Sheet Guide
- ❷ Paper Lever
- ❸ On-Off Switch
- ❹ Platen Knob
- ❺ Control Panel
- ❻ Acoustic Cover
- ❼ Access Cover

*Note: For rear feed, the paper lever must be forward.*

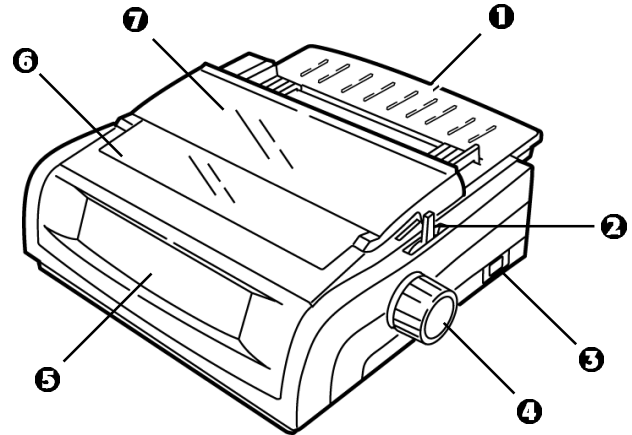

## Parts Identification: Top Feed (Single Sheets)

- ❶ Paper Guides
- ❷ Sheet Guide
- ❸ Paper Lever
- ❹ On-Off Switch
- ❺ Platen Knob
- ❻ Control Panel
- ❼ Acoustic Cover (open)

*Note: For single-sheet printing, the paper lever must be in the middle position.*

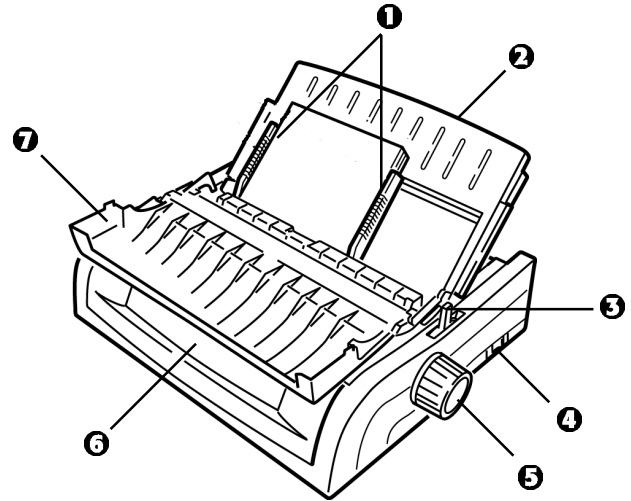

## Top of Form (TOF)

### ***Important!***

*If you turn the platen knob when the printer is on, the Top of Form misaligns. Always shut the printer off before turning the platen knob!*

*Note: The factory default setting for the Top of Form (where the printing should begin) is 1" down from the top of the page.*

Top of Form sets the print start position for the printer. It is adjustable in increments of 1/144 of an inch. The amount of adjustment is limited to avoid paper jams.

The first line prints at the red line of the plastic paper shield (1) on the printhead.

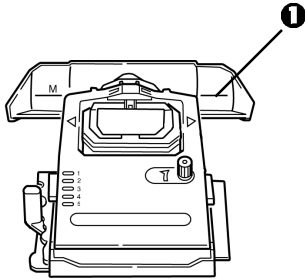

## Top of Form (TOF) and Forms Tear-Off

*Note: Your software may print the first line of print above or below where TOF is set. You may need to adjust the TOF to meet your software's requirements.*

The Top of Form and Forms Tear-Off settings of your printer interact. How you set the Top of Form depends on whether Forms Tear-Off is On (set to 500 ms, 1 sec, or 2 sec) or OFF (the factory default setting).

## Determining if Forms Tear-Off is Off or On

There are two ways to determine the status of the Forms Tear-Off menu setting:

- Print the Menu.
- Use the **TEAR** key.

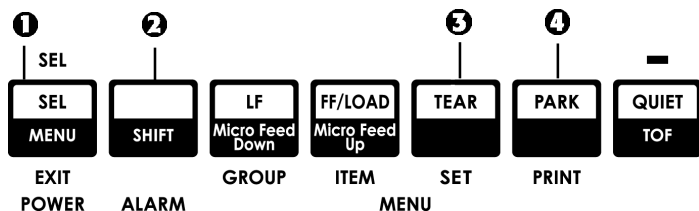

### To print the Menu:

- 1 Make sure paper is loaded.
- 2 Hold **SHIFT** (2), then press **SEL** (1) to enter the Menu Mode.
- 3 Press **PARK** (4) to print the menu.
- 4 Look for the Form Tear-Off setting in the paper feed group you are using (Rear Feed, Bottom Feed or Top Feed—Forms Tear-Off appears in the Top Feed group only if the optional Roll Paper Stand is installed).

### To use the **TEAR** key:

- 1 Make sure paper is loaded.
- 2 Press **TEAR** (3).
  - If the paper moves *up*, Forms Tear-off is *off*.
  - If the paper moves *down*, Forms Tear-off is *on*.

## Setting Top of Form (TOF): Forms Tear-Off OFF (Default Setting)

### Important!

If you turn the platen knob when the printer is on, the Top of Form misaligns. Always turn the printer off before turning the platen knob!

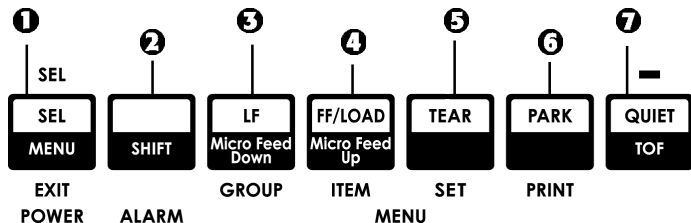

*Note: The first line prints at the red line (1) of the plastic paper shield on the printhead.*

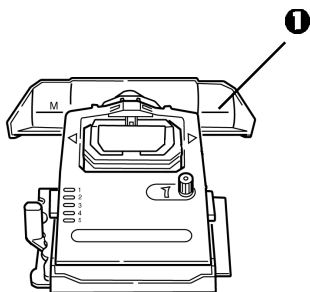

With paper loaded and the printer on and selected:

1 Press **SEL | MENU** (1) to take the printer off line.

*The SEL light goes out.*

2 Press and hold **SHIFT** (2), then

*Note: When you begin pressing the Micro Feed key, the printhead will move to the right.*

- Press **LF | Micro Feed Down** (3) to set the TOF *higher* (the paper moves down).

- Press **FF/LOAD | Micro Feed Up** (4) to set the TOF *lower* (the paper moves up).

3 When you have the TOF set where you want it, press and hold **SHIFT** (2), then press **QUIET/TOF** (7) to engage the new setting.

*The printhead moves back to the left margin.*

4 Press **SEL/MENU** (1) to save the setting and place the printer back on line.

*Note: To reset the Top of Form to the factory default, see “Resetting Top of Form to the Factory Default” later in this chapter.*

## Setting Top of Form (TOF): Forms Tear-Off Set to ON

### Important!

If you turn the platen knob when the printer is on, the Top of Form misaligns. Always turn the printer off before turning the platen knob!

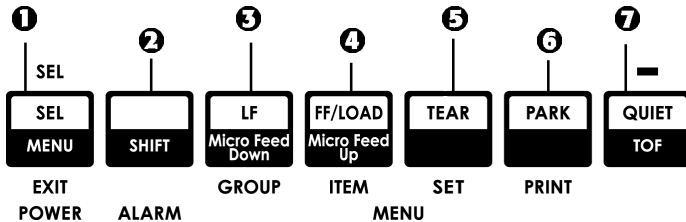

Note: The first line prints at the red line (1) of the plastic paper shield on the printhead.

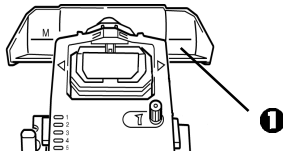

With paper loaded and the printer on and selected:

- 1 Press **PARK** (6) to park the paper.  
The SEL light goes off and the red alarm light comes on.

- 2 Press **SHIFT** (2) and **QUIET/TOF** (7) to reset the current TOF.
- 3 Press **FF/LOAD** (4) to load the paper.
- 4 Wait briefly until the paper moves up to the tear position, then press and hold **TEAR** (5).  
The paper moves to the current TOF.
- 5 Keep holding **TEAR**, then press and hold **SHIFT** (2) and release **TEAR**.
- 6 Continue to hold **SHIFT**, then

Note: When you begin pressing the Micro Feed key, the printhead will move to the right.

- Press **LF | Micro Feed Down** (3) to set the TOF *higher* (the paper moves down).
  - Press **FF/LOAD | Micro Feed Up** (4) to set the TOF *lower* (the paper moves up).
- 7 When you have the TOF set where you want it, press and hold **SHIFT** (2), then press **QUIET/TOF** (7) to engage the new setting.  
The printhead moves back to the left margin.
  - 8 Press **SEL/MENU** (1) to save the setting and place the printer back on line.

Note: To reset the Top of Form to the factory default, see the next page.

## Temporarily Changing the Top of Form Position

### ***Important***

*Do not use the platen knob to change the Top of Form. If you turn the platen knob when the printer is turned on, the Top of Form misaligns. Always turn the printer off before turning the platen knob!*

To move the Top of Form position lower *for one page only*:

- 1 Press **SEL** to deselect the printer.
- 2 Press **LF** to lower the position of the Top of Form.

## Resetting Top of Form to the Factory Default

The factory default setting for the Top of Form (where the printing should begin) is 1" down from the top of the page.

To reset the Top of Form to the factory default:

- 1 Remove paper from the paper path.
- 2 Turn the printer *off*.
- 3 Press and hold **PARK + QUIET/TOF** while turning on the printer.
- 4 Reload paper.



## Forms Tear-Off Feature

*Note: This feature is normally turned off. To use Forms Tear-Off, you must enter the menu and change the setting to the desired time interval (see next page).*

The Forms Tear-Off feature allows a printed continuous forms page to be torn off without wasting paper or adjusting the printer. It can be used for rear feed continuous forms, bottom feed continuous forms (with the optional push tractor installed) or for top feed roll paper (with optional roll paper stand installed).

When the printer is turned on, the paper feeds to the tear-off position.

When data is received, the paper automatically moves down to the print position (TOF) and printing begins.

*Note: You can also move the paper down to the print position manually by pressing **TEAR**.*

When printing stops, Forms Tear-Off automatically moves the paper to align the perforation with the tear bar (located under the access cover), after the time interval which you selected through the menu.

Paper remains in the tear-off position until the printer receives more data. Then, the paper moves back down for printing.

*Notes: The status of the Forms Tear-Off menu setting affects how you set the Top of Form: see “Top of Form (TOF) and Forms Tear-Off” earlier in this chapter.*

*Do not use Forms Tear-Off with labels or multipart forms!*

*Forms Tear-Off cannot be used when the optional pull tractor is engaged.*

## Potential Problems with Software Packages

If Forms Tear-Off is set to On and the software package you are using “pauses” for a long enough interval while sending data to the printer, Forms Tear-Off may be activated. No data is lost, but this causes uneven print registration due to the paper movement.

If this occurs, use the menu to turn off this feature, then use the **TEAR** key to move the paper up to the tear position manually (see next page).

## Changing the Forms Tear-Off Setting

*Note: The default setting for Forms Tear-Off is OFF.*

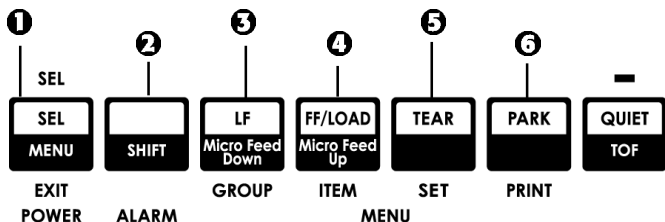

To change the Forms Tear-Off setting:

- 1 Press **SHIFT** (2) + **SEL** (1).
- 2 Press **GROUP** (3) repeatedly until the Rear Feed or Bottom Feed group shows in the first column of the printed line, depending on which paper feed you are using,
- 3 Press **ITEM** (4) repeatedly until Form Tear-Off appears in the second column:  
Rear Feed            Form Tear-Off    Off
- 4 Press **SET** (5) until the time interval you wish to select appears in the third column:  
Rear Feed            Form Tear-Off    1 Sec
- 5 Press **SHIFT** (2) + **SEL** (1) to exit Menu Mode and save the setting.

## Manual Forms Tear Off

If you don't wish to engage the Forms Tear-Off feature, you can advance

- rear-feed continuous forms loaded on the built-in tractor *or*
- bottom-feed continuous forms loaded on the optional push tractor

up to the tear off position manually by pressing **TEAR** (5).

## Paper Park

### ***Important!***

***Never park labels!***

Paper park allows you to switch to single-sheet printing without removing continuous feed paper from the printer.

When you wish to print single sheets, simply press **PARK** (6) to retract the continuous form paper from the paper path, then lift the sheet guide, load the sheet and send the print job.

# Changing Paper Paths

## Continuous Forms to Single Sheets

- 1 Tear off any printed pages, then press **PARK**.
- 2 Raise the sheet guide (1) to the single-sheet feed position.

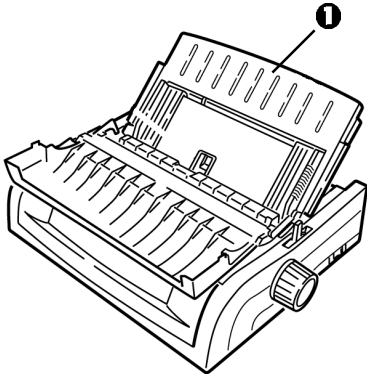

- 3 Pivot the wire feed guide into the sheet guide.

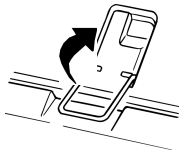

- 4 Move the paper lever (1) to the middle position marked "TOP."

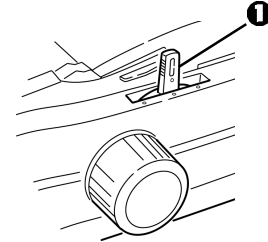

- 5 Adjust the paper guides (1) for the size paper you are using, then place a sheet of paper in the sheet guide.

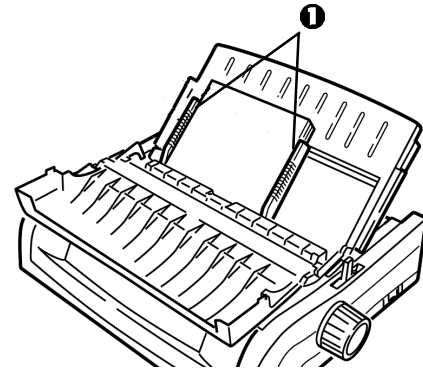

## Single Sheets to Continuous Forms

- 1 Press **FF/LOAD** to remove the single-sheet paper.
- 2 Lower the sheet guide into the continuous-forms position.

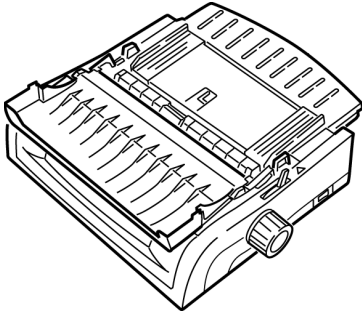

- 3 Swing the wire feed guide over onto the pull-up roller.

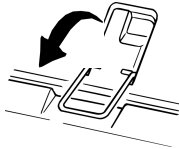

- 4 Move the paper lever to the appropriate position.

- Rear feed:

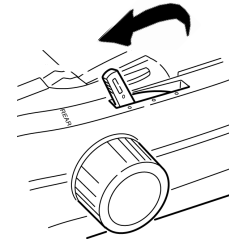

- Bottom feed:

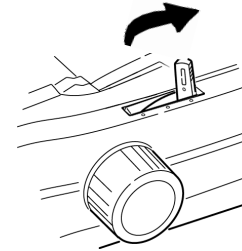

- 5 If necessary, load continuous-form paper.
- 6 Press **FF/LOAD**.

## Printhead Gap

The printhead gap is the distance between the printhead and the platen.

### **CAUTION!**

*Make sure the printer is turned off before you open the access cover.*

To adjust the gap, open the access cover and move the blue lever (1) to the recommended setting from the table.

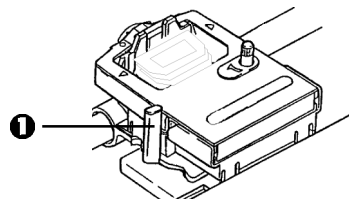

Setting	Media
1	Regular paper
2	2-part form (with carbon)
3	3-part form (with carbon)
4	4-part form (with carbon)
5	Envelopes or extra thick paper

*Note: When the head gap is set to 2, 3, 4 or 5, the printer automatically slows down for better print quality with multipart forms.*

# Print Quality

## **Important!**

*Front panel settings for print quality and character pitch are normally overridden by software commands.*

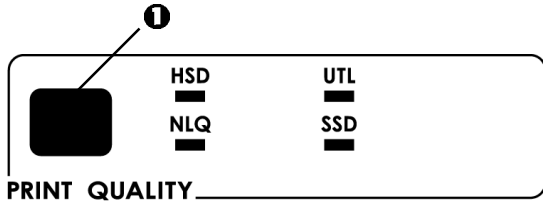

Press **PRINT QUALITY** (1) to select:

## **UTL: Utility—the default**

- Medium quality, medium speed (380 cps)
- Gothic typeface only

## **HSD: High Speed Draft**

- Lower quality, higher speed (507 cps)
- Gothic typeface only

## **SSD: Super Speed Draft**

- Lowest quality, highest speed (570 cps)
- Gothic typeface only

## **NLQ: Near Letter Quality**

- Highest quality, slowest speed (95 cps)
- Courier or Gothic

# Character Pitch

## **Important!**

*Front panel settings for character pitch are normally overridden when the SI command is received from your software.*

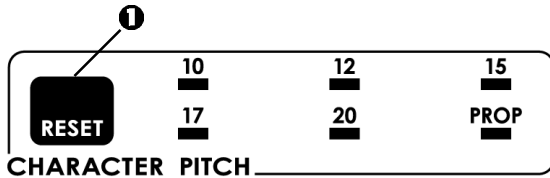

Character pitch determines how many characters will print on each line. You can choose a specific fixed width for each character in characters per inch (CPI), or Proportional. The higher cpi settings are often used for spreadsheets.

Proportional (PROP) sets character widths based on the character itself: e.g., the letter i is assigned a narrower width than the letter m. This provides a more polished, typeset appearance.

*Note: To reset the printer to the factory default character pitch, deselect the printer, then press and hold the **SHIFT** key while pressing the **CHARACTER PITCH** key.*

# Epson and IBM Emulations

Set the character pitch by pressing **CHARACTER PITCH** (1) until the light beneath the desired setting is lit:

- 10 cpi
- 12 cpi
- 15 cpi
- 17 cpi
- 20 cpi
- Proportional

## MICROLINE Emulation

In the MICROLINE emulation, the Character Pitch choices are:

- 10 cpi, Proportional or non-proportional
- 12 cpi, Proportional or non-proportional
- 15 cpi, Proportional or non-proportional
- 17 cpi, Proportional or non-proportional
- 20 cpi, Proportional or non-proportional

To select Proportional, press the **CHARACTER PITCH** key until *both* the cpi value and PROP lights are lit.

To select non-proportional, press the **CHARACTER PITCH** key until the light for the cpi value you wish to use is lit.

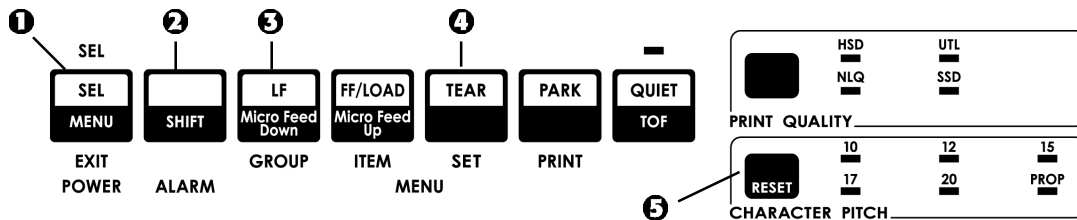

## Printer Reset

Clearing some error conditions requires that you reset (reinitialize) the printer. To do this:

- 1 Press and release **SEL** (1) to take the printer off-line.  
*The SEL light goes out.*
- 2 Press and hold **SHIFT** (2), then press the **RESET/CHARACTER PITCH** key.

### **Important!**

*Pressing **SHIFT** + **RESET** reinitializes the printer, but does not affect any menu settings and does not reset the printer to the factory defaults. For information on resetting the printer to the factory defaults, see “Resetting the Menu to the Factory Defaults” later in this chapter.*

## Emulations

- IBM® Proprinter III — *factory setting*
- Epson® FX
- Oki® MICROLINE®

## Changing Emulations

- 1 Make sure paper is loaded.
- 2 Press and hold **SHIFT** (2), then press **SEL** (1).
- 3 Press **LF** (3).  
*The following line prints:*  
Printer Control Emulation Mode IBM PPR
- 4 Press **TEAR** (4) repeatedly until the emulation you wish to select prints in the right-hand column.
- 5 Press and hold **SHIFT** (2), then press **SEL** (1) to save your setting and exit the Menu Mode.



# Chapter 4: Menu Mode

*Note: Please print the current Menu Mode settings before you reset or change them. This is the only way to have a record of the settings.*

In Menu Mode, you use the front panel keys to change the defaults for the printer parameters. The changes you make in the Menu Mode are automatically saved when you exit the Menu Mode and are retained, even when you turn the printer off.

## Menu Mode Keys

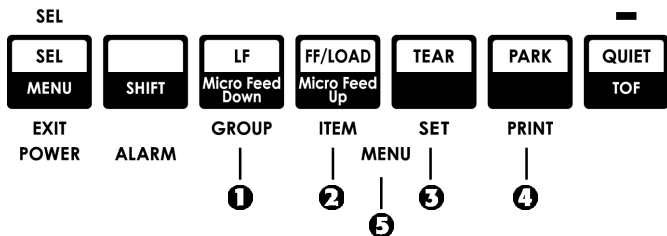

### ❶ GROUP Key

Prints the next Group in the Menu.

With the **SHIFT** key, prints the previous Group.

### ❷ ITEM Key

Prints the next Item in the Group.

With the **SHIFT** key, prints the previous Item in the Group.

### ❸ SET Key

Prints the next setting for an Item.

With the **SHIFT** key, prints the previous setting for an Item.

### ❹ PRINT Key

Prints a copy of all the Menu settings.

With the **SHIFT** key, prints the current settings for the Group selected.

### ❺ MENU Light

Glow when the printer is in the Menu Mode.

## Entering and Exiting Menu Mode

To enter or exit the Menu Mode, hold **SHIFT** while pressing **SEL**.

## Resetting the Menu to the Factory Defaults

*Note: Please print the current Menu Mode settings before you reset or change them. This is the only way to have a record of the settings.*

To reset the Menu to the standard settings (factory defaults):

- 1 Turn the printer off.
- 2 Press **SEL + LF** while turning the printer on.

## Printing the Menu Settings

### Printing the Current Menu Settings

- 1 Make sure paper is loaded in the printer.
- 2 Press and hold **SHIFT**, then press **SEL** to enter the Menu Mode.
- 3 Press **PRINT (PARK key)**.

### Printing All Menu Settings

To print out a listing of the settings for all menu items, regardless of the emulation selected or the accessories installed:

- 1 Make sure paper is loaded in the printer.
- 2 Press and hold **SHIFT**, then press **SEL** to enter the Menu Mode.
- 3 Press and hold **SHIFT**, then press **PRINT QUALITY**.

## Changing the Menu Settings

*Note: Please print the current Menu Mode settings before you reset or change them. This is the only way to have a record of the settings.*

- 1** Press and hold **SHIFT**, then press **SEL** to enter the Menu Mode.
- 2** Use the **GROUP**, **ITEM** and **SET** keys to make your changes:
  - a** Press **GROUP** until the Group you wish to change appears in the first column.
  - b** Press **ITEM** until the Item you wish to change appears in the second column.
  - c** Press **SET** until the setting you want appears in the third column.
- 3** Press and hold **SHIFT**, then press **SEL** to exit the Menu Mode and save your settings.

### ***Important!***

*If you turn off the printer without first exiting the Menu Mode, the changes you have made will be lost.*

## Menu Settings Table

For a complete explanation of each menu item, see “Explanations of Menu Items” later in this chapter.

The table below shows the items which may appear in the menu. Settings which are engaged at the factory (defaults) are set in ***bold italic***. Some groups or entries will only appear when a specific emulation is engaged, as noted.

Group	Item	Settings (Defaults are set in <b><i>bold italic</i></b> )
Printer Control	Emulation Mode	<b><i>IBM PPR</i></b> , Epson FX, ML
Font	Print Mode	<b><i>LQ Courier</i></b> , LQ Roman, LQ Swiss, LQ Swiss Bold, LQ Orator, LQ Gothic, LQ Prestige, Utility, HSD
	DRAFT Mode	<b><i>HSD</i></b> , SSD
	Pitch	<b><i>10 cpi</i></b> , 12 cpi, 15 cpi, 17.1 cpi, 20 cpi
	Proportional Spacing	<b><i>No</i></b> , Yes
	Style	<b><i>Normal</i></b> , Italics
	Size	<b><i>Single</i></b> , Double
Symbol Sets	Character Set	<ul style="list-style-type: none"> <li>• <b><i>Set I</i></b>, Set II [Epson and IBM mode]</li> <li>• Standard, Line Graphics, Block Graphics [ML Mode]</li> </ul>
	Language Set	<b><i>American</i></b> , French, German, British, Danish I, Swedish, Italian, Spanish I, Japanese, Norwegian, Danish II, Spanish II, Latin American, French Canadian, Dutch, Publisher
	Zero Character	<b><i>Slashed</i></b> , Unslashed
	Code Page	<b><i>USA</i></b> , Canada French, Multilingual, Portugal, Norway, BRASCII, Abicom, Multilingual 858, ISO 8859-15

## Menu Settings Table (Continued)

Group	Item	Settings (Defaults are set in <i>bold italic</i> )
Rear Feed	Line Spacing Form Tear-Off Skip Over Perforation Page Width (wide model) Page Length	<i>6 LPI</i> , 8 LPI <i>Off</i> , 500 ms, 1 sec, 2 sec <i>No</i> , Yes <i>13.6"</i> , 8" <i>11"</i> , 11-2/3", 12", 14", 17", 5", 3", 3.5", 4", 5.5", 6", 7", 8", 8.5"
Bottom Feed	Line Spacing Form Tear-Off Skip Over Perforation Page Width (wide model) Page Length	<i>6 LPI</i> , 8 LPI <i>Off</i> , 500 ms, 1 sec, 2 sec <i>No</i> , Yes <i>13.6"</i> , 8" <i>11"</i> , 11-2/3", 12", 14", 17", 5", 3", 3.25", 3.5", 4", 5.5", 6", 7", 8", 8.5"

## Menu Settings Table (Continued)

Group	Item	Settings (Defaults are set in <i>bold italic</i> )
Top Feed	Line Spacing	<i>6 LPI</i> , 8 LPI
	Form Tear-Off*	<i>Off</i> , 500 ms, 1 sec, 2 sec
	Bottom Margin	<i>Valid</i> , Invalid
	Page Width (wide model)	<i>8"</i> , 13.6"
	Page Length	<i>11"</i> , 11-2/3", 12", 14", 17", 5", 3", 3.25", 3.5", 4", 5.5", 6", 7", 8", 8.5"
	Wait Time	<i>500 ms</i> , <i>1 sec</i> , 2 sec
	Page Length Control	<i>by Actual Page Length</i> , by MENU Setting
Set-Up	Graphics	Bi-directional, <i>Uni-directional</i>
	7 or 8 Bit Graphics†	8, 7
	Receive Buffer Size	1 Line, 32K, <i>64K</i> , <i>128K</i>
	Paper Out Override	<i>No</i> , Yes

\* Appears only when the optional Roll Paper Stand is installed.

† Appears only when the MICROLINE emulation is selected.

## Menu Settings Table (Continued)

Group	Item	Settings (Defaults are set in <i>bold italic</i> )
Setup (cont..)	Print Registration 1	<i>0</i> , range to 0.25 mmm to the right or left, set in 0.05 mm increments <ul style="list-style-type: none"> <li>• press SEL to shift registration to the left;</li> <li>• press SHIFT + SEL to shift registration to the right.</li> </ul>
	Print Registration 2	<i>0</i> , range to 0.25 mmm to the right or left, set in 0.05 mm increments <ul style="list-style-type: none"> <li>• press SEL to shift registration to the left;</li> <li>• press SHIFT + SEL to shift registration to the right.</li> </ul>
	7 or 8 Bits Data Word*	<i>8, 7</i>
	Operator Panel Function	<i>Full Operation</i> , Limited Operation
	Reset Inhibit	<i>No</i> , Yes
	Print Suppress Effective	No, <i>Yes</i>
	Auto LF	<i>No</i> , Yes
	Auto CR <sup>†</sup>	<i>No</i> , Yes
	CSF Bin Select**	<i>Bin 1</i> , Bin 2
Print DEL Code*	<i>No</i> , Yes	

\* Appears only when MICROLINE emulation is selected.

† Appears only when the IBM emulation is selected.

\*\* Appears only if the optional Cut Sheet Feeder is installed.

## Menu Settings Table (Continued)

Group	Item	Settings (Defaults are set in <i>bold italic</i> )
	SI Select Pitch (10 cpi)*	15 cpi, <i>17.1 cpi</i>
	SI Select Pitch (12 cpi)*	<i>12 cpi</i> , 20 cpi
	Time Out Print	<i>Valid</i> , Invalid
	Auto Select	<i>No</i> , Yes
	Centering Position	<i>DEFAULT</i> , MODE 1, MODE 2
	CSF Type†	<i>Wide</i> , Narrow
	Power Save Time	<i>5 min</i> , 10 min, 15 min, 30 min, 60 min
Parallel I/F	I-Prime	<i>Buffer Print</i> , Buffer Clear, Invalid
	Auto Feed XT**	<i>Invalid</i> , Valid
	Bi-Direction	<i>Enable</i> , Disable

\* Appears only when the IBM emulation is selected.

† Appears only when optional Cut Sheet Feeder is installed.

\*\* Appears only if the Epson emulation is selected.



## Menu Settings Table (Continued)

Group	Item	Settings (Defaults are set in <i>bold italic</i> )
Serial IF*	Parity	<i>None</i> , Odd, Even
	Serial Data 7/8 Bits	<b><i>8 Bits</i></b> , 7 Bits
	Protocol	<b><i>Ready/Busy</i></b> , X/On / X/Off
	Diagnostic Test	<i>No</i> , Yes
	Busy Line	<b><i>SSD-</i></b> , SSD+, DTR, RTS
	Baud Rate	19200 bps, <b><i>9600 bps</i></b> , 4800 bps, 2400 bps, 1200 bps, 600 bps, 300 bps
	DSR Signal	<b><i>Valid</i></b> , Invalid
	DTR Signal	<b><i>Ready on Power Up</i></b> , Ready on Select
	Busy Time	<b><i>200 ms</i></b> , 1 sec.

\* Appears only when the optional Serial Interface is installed.

## Menu Settings Table (Continued)

Group	Item	Settings (Defaults are set in <i>bold italic</i> )
CSF Bin 1*	Line Spacing	<b>6 LPI</b> , 8 LPI
	Bottom Margin	<b>Valid</b> , Invalid
	Page Width (Wide model)	<b>8"</b> , 13.6"
	Page Length	<b>11"</b> , 11-2/3", 12", 14", 17", 5", 3.5", 4", 5.5", 6", 7", 8", 8.5"
CSF Bin 2*	Line Spacing	<b>6 LPI</b> , 8 LPI
	Bottom Margin	<b>Valid</b> , Invalid
	Page Length	<b>11"</b> , 11-2/3", 12", 14", 17", 5", 3.5", 4", 5.5", 6", 7", 8", 8.5"

\* Appears only when the optional Cut Sheet Feeder is installed.

## Explanations of Menu Items

These explanations are in alphabetical sequence to make it easier to look them up. Some items only appear when optional accessories are installed; others appear in several groups in the menu.

### **7 or 8 Bit Graphics, Default = 7**

Change this setting to 8 if your system uses 8-bit graphics.

### **7 or 8 Bit Data Word, Default = 8**

Change this setting to 7 if your system uses 7-bit data word lengths.

### **Auto CR, Default =No**

IBM emulation only. If you want the printer to automatically add a carriage return when a Line Feed is received at the end of a line, change the setting to Yes.

### **Auto LF, Default = No**

If your printout is consistently double spaced, select No; if it overprints, select Yes.

### **Auto Feed XT, Default = Invalid**

Epson emulation only. In the Epson emulation, the XT signal on pin 14 of the parallel interface can control automatic line feed. Some interface cables are wired in such a way that automatic line feed is always in effect: this item eliminates this potential problem. If your system uses pin 14 of the parallel interface to control automatic line feed, change the setting to Valid.

### **Auto Select, Default = No**

Determines whether or not your printer will automatically be selected after you load in paper. With the factory default engaged, the printer will be deselected so that you can set the Top of Form. If you always use the same Top of Form position, change the setting to Yes.

### **Baud Rate, Default = 9600 bps**

Appears only if optional Serial Interface is installed. Set this to match your system's transmission speed.

### **Bi-direction, Default = Enable**

Change this setting if you wish to disable bidirectional transmission (PnP) in Nibble mode.

**Bottom Margin, Default = Valid**

Change to Invalid if you want the printer to ignore the bottom margin setting.

**CAUTION!!**

*Setting the Bottom Margin to Invalid can cause loss of data and damage the printhead by allowing printing without paper.*

**Busy Line, Default = SSD-**

Appears only when the optional Serial Interface is installed. If Ready/Busy protocol (factory default) is selected, you can choose which line your system monitors for a busy signal:

- SSD -9V, select SSD-
- SSD +9V, select SSD+
- DTR -9V, select DTR
- RTS -9V, select RTS

**Busy Time, Default = 200 ms**

Appears only when the optional Serial Interface is installed. Sets the length of the busy signal when the Ready/Busy protocol (factory default) is engaged,

**Centering Position, Default = DEFAULT**

Used to limit printhead travel when printing narrow columns.

- Select Mode 1 for the narrow carriage printer.
- Select Mode 1 or Mode 2 for the wide carriage printer.

**Character Set, Default = IBM Set I**

Epson and IBM emulations only. Use this to switch character sets to IBM Set II

**Character Set, Default = Standard**

MICROLINE emulation only. Use this to switch the character set to Line Graphics.

**Code Page, Default = USA**

Choose the Code Page character set you wish to use: USA, Canada French, Multilingual, Portugal, Norway, BRASCII, Abicomp, Multilingual 858, or ISO 8859-15.

**CSF Bin Select, Default = Bin 1**

Appears only when the optional Dual-Bin Cut Sheet Feeder is installed. Use this to switch to Bin 2 as the default.

**CSF Type, Default = Wide**

To avoid paper jams, change this setting to Narrow if you are using the optional Cut Sheet Feeder on the wide model ML421 printer.

**Diagnostic Test, Default = No**

Appears only when the optional Serial Interface is installed. Select yes to perform a diagnostic test of the serial interface.

**DRAFT Mode, Default = HSD**

Applies only when the Print Mode is set to DRAFT. Selects the draft mode to be used: HSD (High Speed Draft) or SSD (Super Speed Draft).

**DSR Signal, Default = Valid**

Appears only when the optional Serial Interface is installed. Used with the Ready/Busy protocol (factory default) to select the way your system handles the DSR signal.

**DTR Signal, Default = Ready on Power Up**

Appears only when the optional Serial Interface is installed. Change to Ready on Select if the DTR signal is required when the printer is selected (leave as Ready on Power Up if the DTR signal is required when the printer is turned on).

**Emulation Mode, Default = IBM PPR**

Selects the printer command set (emulation) you want to engage.

**ESC SI Pitch, Default = 17 cpi**

Sets the character pitch used when the ESC SI command is received.

**Form Tear-Off, Default = Off**

Choose 500 ms, 1 sec, or 2 sec to turn the Form Tear-Off feature on and to set the time interval for the printer to wait before advancing the paper.

**Graphics, Default = Bi-directional**

Change to uni-directional graphics for better registration, but slower printing. With this set for bi-directional, you can optimize the registration using the Print Registration setting in the Menu.

**I-Prime, Default = Buffer Print**

Determines what the printer will do when it receives the I-Prime signal from the software.

- Buffer Print: prints out the buffer contents before resetting.
- Buffer Clear: dumps the buffer contents immediately.
- Invalid: causes the printer to ignore the I-Prime command. Select this setting if you wish to enter settings through the printer's control panel which will not be automatically overridden by the software's settings when the I-Prime signal is sent.

**Language Set, Default = American**

Replaces certain standard symbols with special characters used in foreign languages.

**Line Spacing, Default = 6 lpi**

Change to 8 lines per inch (lpi) to get more lines on a page.

**Operator Panel Function, Default = Full Operation**

Change to Limited Operation to deactivate the **PRINT QUALITY** and **CHARACTER PITCH** buttons, so that these features can only be controlled through your software. This prevents these from being changed from the control panel when several people are using the printer.

***Important!***

*This feature also prevents access to the Menu. To access the Menu in these circumstances, turn the printer off, then hold down the **SEL** key while turning on the printer.*

**Page Length, Default = 11"**

Selects the length of the paper you are using. This enables the printer to keep track of the initial printing position (TOF) on each page.

**Page Length Control, Default = by Actual Page Length**

If you are printing single sheets no longer than 17 inches and wish the printer to acknowledge the menu setting for Top Feed Page Length, change the setting to "by Menu Setting."

**Page Width, Default = Depends on Feed Path**

Wide carriage model only.

For rear and bottom paths, the default is 13.6". Change to 8" if you will be printing on narrow paper. This prevents printing on the platen which can damage the printhead and the platen, and can cause loss of data.

For the top feed path the default is 8". Change to 13.6" to print on wide paper.

**Paper Out Override, Default = No**

Senses when less than 1" (25 mm) of paper remains and stops printing. Change to Yes to override the sensor and print closer to the bottom of the page.

**Caution!!**

*Engaging Paper Out Override can cause loss of data and damage the printhead by allowing printing without paper.*

**Parity, Default = None**

Appears only when the optional Serial Interface is installed. Selects the type of parity your system uses: None, Odd or Even.

**Pitch, Default = 10 cpi**

Choose the character width, in characters per inch (cpi).

**Power Save Time, Default = 5 min**

Sets the interval the printer waits for more data before it goes into the power save mode.

**Print Mode, Default = Utility**

Choose the quality and typeface of printing. Switch to NLQ Courier or NLQ Gothic for Near Letter Quality printing. If you are printing draft-type documents, select DRAFT, then select either HSD or SSD under DRAFT Mode. Both of these Items are in the Font Group.

**Print Registration, Default = 0**

Change the setting as required to obtain the best registration for bi-directional printing.

**Print Suppress Effective, Default = Yes**

If your system uses the DC1 and DC3 codes for something other than the print suppress mode, change the setting to No.

**Proportional Spacing, Default = No**

Change the setting to Yes to engage proportional spacing of characters.

**Protocol, Default = Ready/Busy**

Appears only if the optional Serial Interface is installed. Change to X-ON / X-Off if that is the type of protocol your system uses.

**Receive Buffer Size, Default = 64K**

Selects the amount of memory devoted to holding received data. Choosing 1 Line will tie up your computer while printing, but if you abort the print job, the printer will stop much sooner.

**Reset Inhibit, Default = No**

Select Yes if you wish the printer to ignore the reset command sent by software. This prevents your software from changing the settings you make through the front panel controls or through printer commands.

*Note: This will also prevent your software from clearing out existing settings when you finish printing one document and switch to another.*

**Serial Data 7/8 Bits, Default = 8 Bits**

Appears only if the optional Serial Interface is installed. Change to 7 Bits if you systems uses a 7-bit data format.

**SI Select Pitch 10 cpi, Default = 17.1 cpi**

IBM emulation only. Sets the pitch to be engaged when the printer control panel is set for 10 cpi and the SI command is received.



**SI Select Pitch 12 cpi, Default = 20 cpi**

IBM emulation only. Sets the pitch to be engaged when the printer control panel is set for 12 cpi and the SI command is received.

**Size, Default = Single**

Change to Double for double width and height printing.

**Skip Over Perforation, Default = No**

Change to Yes if you want the printer to go to the next page when it comes within 1" (25 mm) of the bottom of the page. Keep it set to No if your software has its own page formatting controls.

**Style, Default = Normal**

Change to italics if you want the printed characters to be slanted.

**Time Out Print, Default = Valid**

If your software spends a long time processing between portions of data it feeds to the printer, change the setting to Invalid to keep your printer from dumping the received data while it is waiting for more.

**Wait Time, Default = 1 sec**

Sets the amount of time the printer will wait for more data before moving to the form tear-off position.

**Zero Character, Default = Slashed**

If you do not want the printer to use a slash to distinguish the number zero from the capital letter O, change the setting to Unslashed.

# Chapter 5: Maintenance

## Replacing the Ribbon Cartridge

### ***Important!***

*Make sure you have the correct replacement ribbon for the your printer. The wrong ribbon will not print when installed in your printer. Look for the printer model number on the ribbon package.*

### **Ribbon Cartridge Handling**

- Leave unused ribbon cartridges in their packages until needed.
- Careful; the ribbon ink may cause permanent stains.
- Ribbon ink on skin or clothing can usually be removed with soap and water.

- 1 *Make sure the printer is turned OFF.*
- 2 Open the access cover and center the printhead.

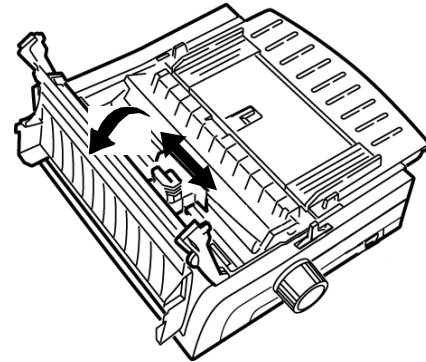

**CAUTION!**

*The printhead may be **HOT!***

- 3 Swing the used ribbon cartridge up off the printhead, lift it out, and discard it.

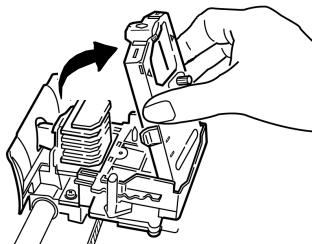

- 4 Unpack the new ribbon cartridge and install it.

**Important!**

*Do not remove the ribbon shield (1) from the ribbon!*

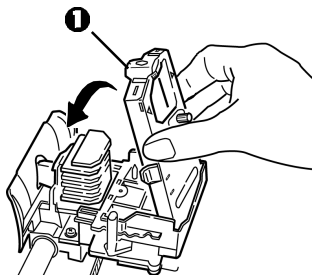

- 5 Turn the take-up knob (1) in the direction of the arrow to take up any ribbon slack.

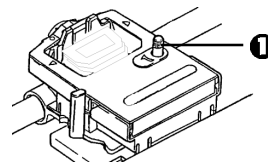

- 6 Close the access cover and turn the printer back on.

**CAUTION!**

**If ribbon should contact the eyes:**

Flush eyes with large quantities of water for 15 minutes, keeping eyelids open with fingers. Seek medical attention.

**If ribbon should contact the skin**

Wash thoroughly with soap and water.

**For more information**

See the Material Safety Data Sheet in your *Warranty, Regulatory, and Safety Information* booklet.

# Loading Paper

## Rear Feed

*Note: If you have any paper in the paper path, remove it before installing rear feed paper.*

- ❶ Lock Lever
- ❷ Upper Tractor Cover
- ❸ Pins

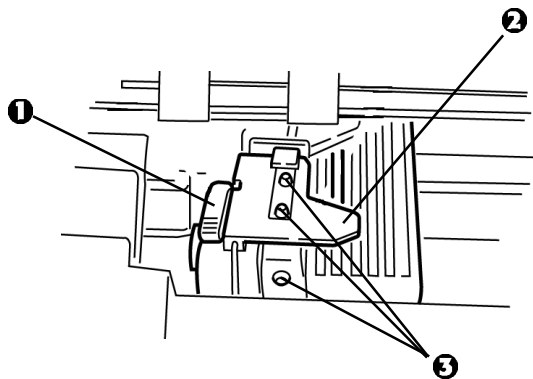

## Loading Rear Feed Paper from the *Back* of the Printer

*Note: These instructions assume you have ready access to the back of the printer. If you do not, skip down to “Loading Rear Feed Paper from the Front of the Printer.”*

- 1 Make sure the paper lever is forward (position marked “REAR”).

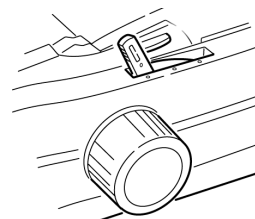

- 2 Open the access cover (1).

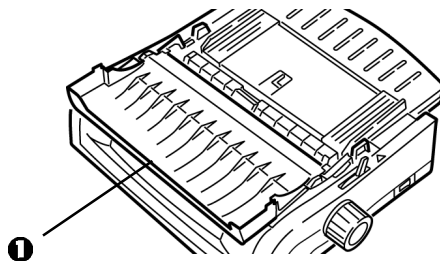

3 Grasp the sheet guide. Lift it slightly, then slide it back.

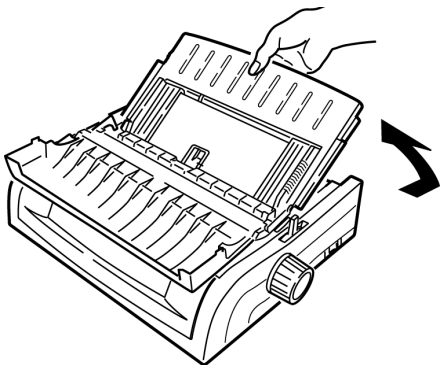

4 Pivot the sheet guide forward and gently rest it against the roller assembly.

**Careful!**

*If you push the sheet guide too hard against the roller assembly, it may dislodge it. If it does, be sure to reseat the roller assembly before continuing.*

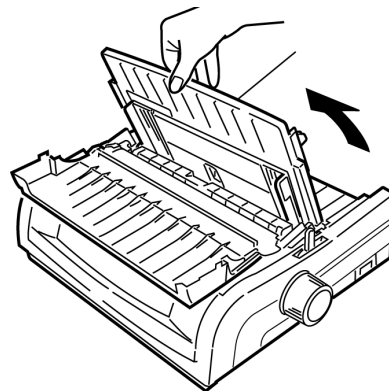

5 From the back of the printer, locate the tractors (1).

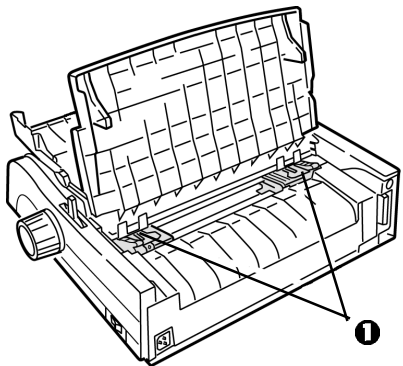

6 Open the lock levers (1) and move the right tractor (*as viewed from the back of the printer*) to the reference mark (2) matching the width of the paper you are loading. Then close the lock lever on the right tractor:

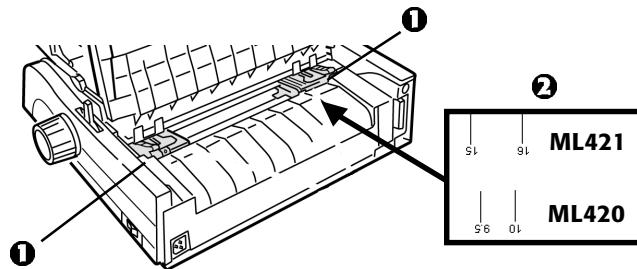

*Note: The movement of the right tractor is limited to ensure that the paper covers the paper sensor.*

7 Open the tractor covers.

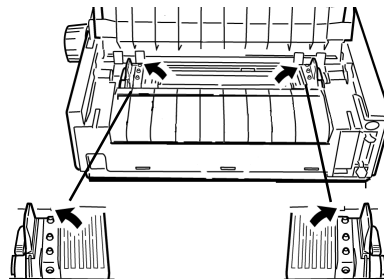

- 8 Place continuous forms paper on the first two pins of either tractor.

**Important!**

*You must keep the number of paper holes engaged on either pin the same. If you don't the paper will skew and jam.*

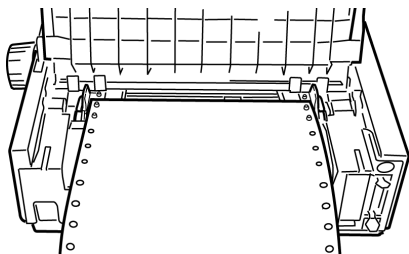

- 9 Close the right tractor cover.

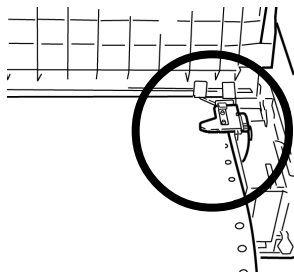

- 10 Adjust the left tractor until the holes in the paper are centered on the pins then lock the lever and close the left tractor cover.

*Note: If the paper is too loose or too tight it can cause jams.*

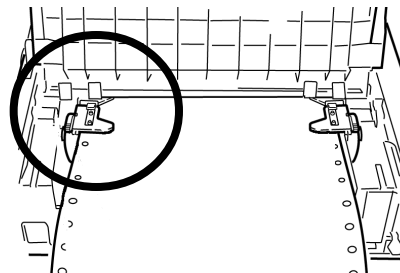

- 11** Lower the sheet guide and slide it toward the front of the printer until the marks align.

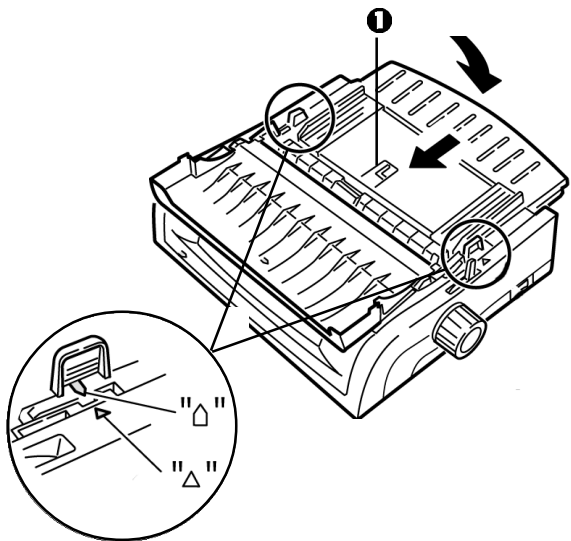

- 12** Place the wire guide ("1" in the illustration for the step above) in the sheet guide on the pull-up roller assembly.

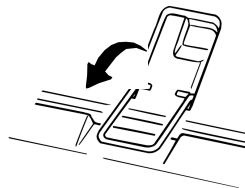

- 13** Press **FF/LOAD**.

*Note: The factory default setting for the Top of Form (where the printing should begin) is 1" down from the top of the page. To change the setting, see "Top of Form (TOF)" in Chapter 3.*



## Loading Rear Feed Paper from the **Front** of the Printer

*Note: These instructions assume you do not have ready access to the back of the printer. If you do, go back to “Loading Rear Feed Paper from the Rear of the Printer” earlier in this chapter.*

- ❶ Lock Lever
- ❷ Upper Tractor Cover
- ❸ Pins

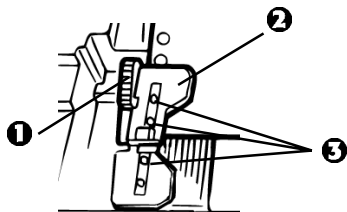

- 1 Make sure the paper lever is forward (position marked “REAR”).

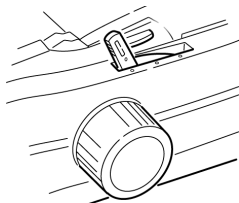

- 2 Open the access cover (1).

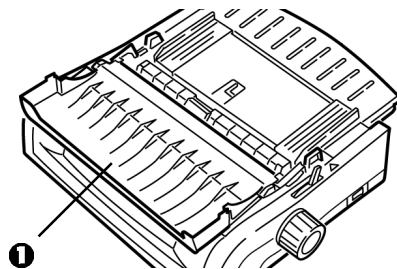

- 3 Grasp the tabs and lift off the sheet guide.

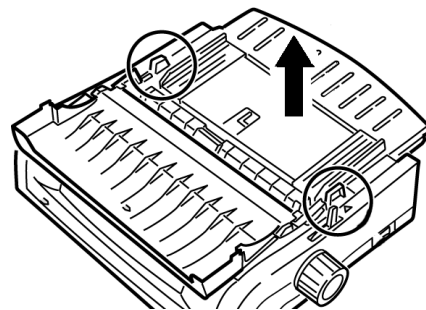

- 4 Pull up on the lock levers to release them.

*Note: The movement of the left tractor (as viewed from the front of the printer) is restricted to ensure that the paper covers the paper out sensor.*

- 5 You will find reference marks (1 in illustration below) on the printer for the two most common paper sizes:



- 6 Move the left tractor to the position to match your paper size and push back on the lever to lock it in place, then move the right tractor to fit the width of the paper.

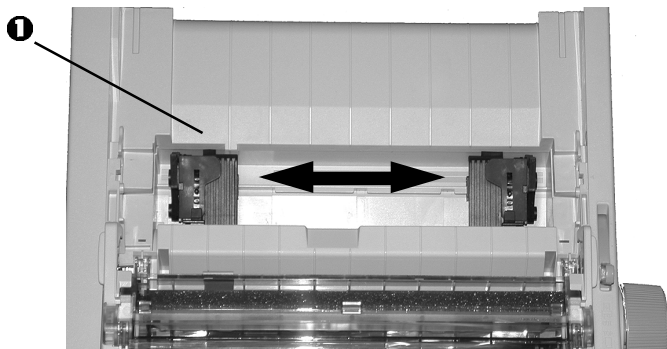

- 7 Open the tractor covers and place continuous forms paper on the first two pins of either tractor, then close the *left* tractor cover.

***Important!***

*You must keep the number of paper holes engaged on either pin the same. If you don't the paper will skew and jam.*



- 8 Adjust the position of the right tractor to center the holes in the paper on the pins. Then, close its tractor cover and push back the lock lever. Do not stretch the paper.

*Note: If the paper is too loose or too tight it can cause jams.*

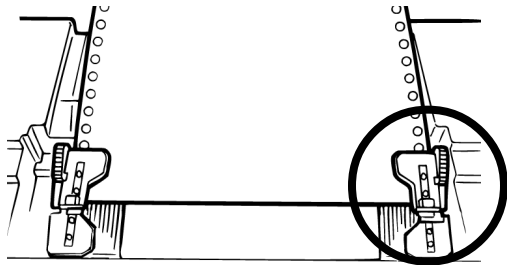

- 9 Reinstall the sheet guide.

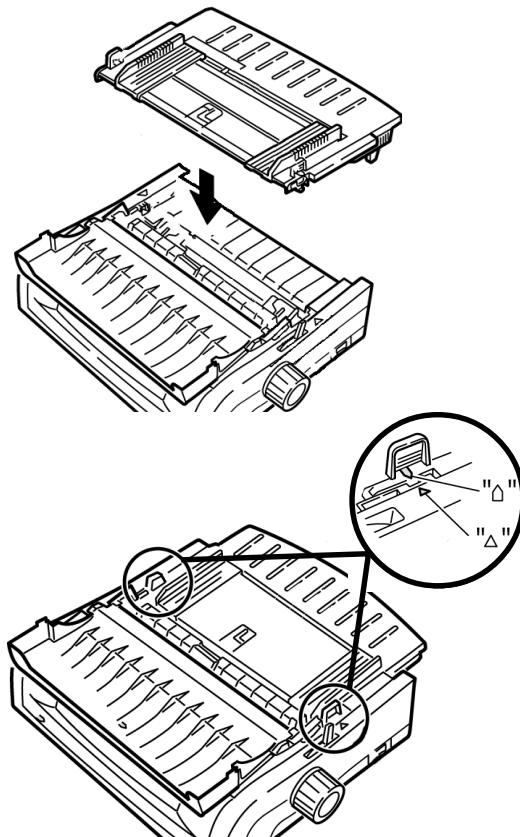

**10** Place the wire guide (1) in the sheet guide on the pull-up roller assembly.

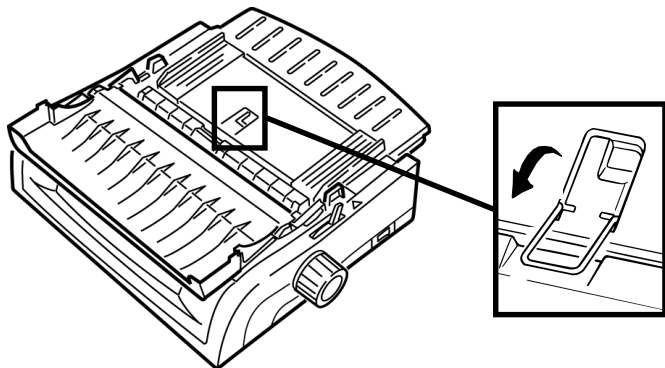

**11** Press **FF/LOAD**.

*Note: The factory default setting for the Top of Form (where the printing should begin) is 1" down from the top of the page. To change the setting, see "Top of Form (TOF)" in Chapter 3.*

## Top Feed (Single Sheets)

*Note: If you have continuous form paper in the path, press **PARK** to remove it before loading single sheets.*

- 1 Make sure the printer is on and *deselected* (**SEL** light off).
- 2 Place the paper lever in the center position (marked “TOP”).

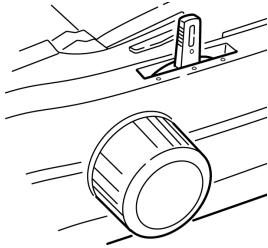

- 3 Open the acoustic cover (1) and raise the sheet guide to the single-sheet position. Pivot the wire feed guide (2) up into the sheet guide.

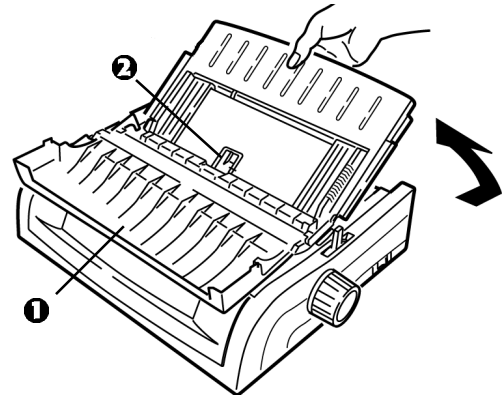

- 4 Adjust the paper feed guides (1) for the width of the paper, then place a sheet of paper in the separator. The paper will feed into the printer.

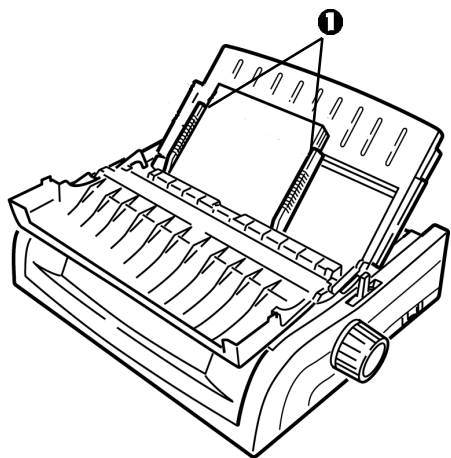

***Important!***

*If the paper does not feed in, remove it. Check the paper lever position. Make sure the **ALARM** light is on: if it is flashing, hold the **SHIFT** key and press the **CHARACTER PITCH/RESET** key. Reload the sheet of paper.*

*Note: The factory default setting for the Top of Form (where the printing should begin) is 1" down from the top of the page. To change the setting, see "Top of Form (TOF)" in Chapter 3.*

# Clearing Paper Jams

## Rear-Feed Paper Jams

- 1 Turn off the printer.
- 2 Use the platen knob to back the paper all the way out of the printer.

### **CAUTION!**

*Make sure the printer is turned off before you open the access cover.*

- 3 Open the access cover (1) and remove the pull-up roller assembly (2). Remove any torn pieces of paper.

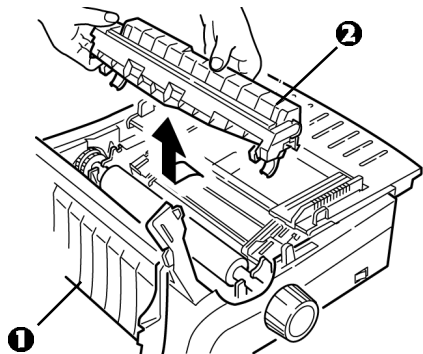

- 5 Lift the sheet guide (1) and reload paper. Make sure you lock the tractor covers.

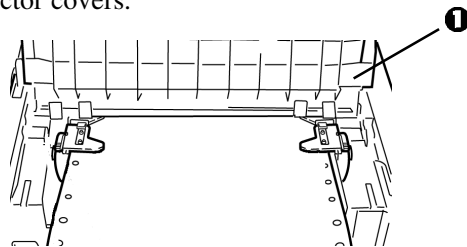

- 5 Lower the sheet guide, then install the pull-up roller assembly and close the access cover.

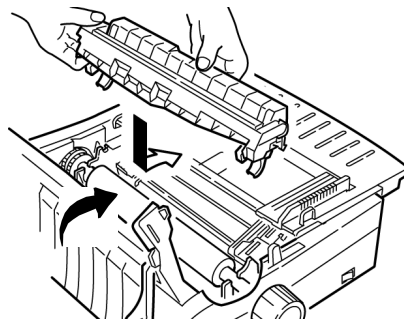

- 6 Turn on the printer and press **FF/LOAD**.

## Rear-Feed, Repeating Paper Jams

If the paper keeps jamming, you may have:

- defective paper
- misaligned paper
- bits of paper stuck in the paper path

### Defective Paper

Replace the paper with a fresh stack.

### Misaligned Paper

- 1 Turn off the printer.
- 2 Use the platen knob to back the paper all the way out of the printer.
- 3 Tear off a couple of sheets of paper, leaving a new, clean, square-cut edge.
- 4 Reload the paper and turn the printer back on.

### Bits of Paper Stuck in the Paper Path

- 1 Turn off the printer.
- 2 Use the platen knob to back the paper all the way out of the printer.

#### **CAUTION!**

*Make sure the printer is turned off before you open the access cover.*

- 3 Open the access cover (1) and remove the pull up roller assembly (2). Then grasp the tabs (3) on the sheet guide (4) and lift it off the printer.

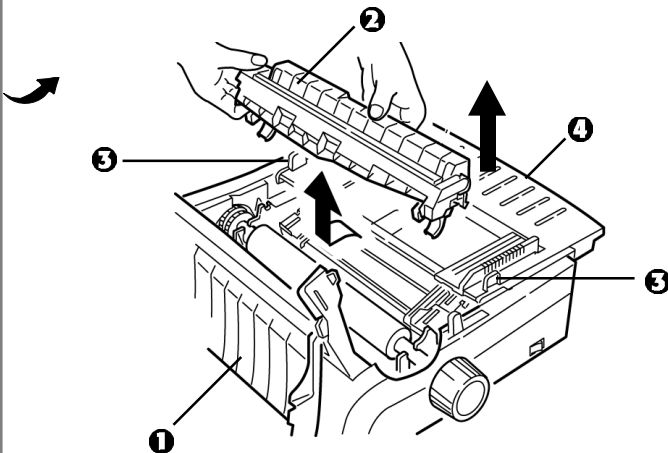



- 4 Remove any torn pieces of paper.
- 5 Fold some continuous-form paper over three times to make a page four sheets thick. Then, load it on the tractors and close and lock the covers.

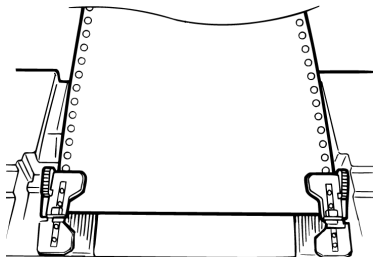

- 6 Use the platen knob to draw the quadruple-thick page around the platen. This brings out jammed pieces of paper.
- 7 Remove the paper pieces. Then, use the platen knob to back the paper out.

- 8 Load regular paper, close and lock the tractor covers.

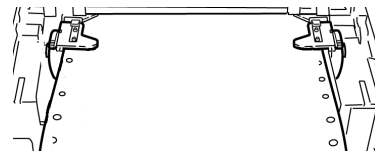

- 9 Install the sheet guide, then install the pull-up roller assembly and close the access cover.

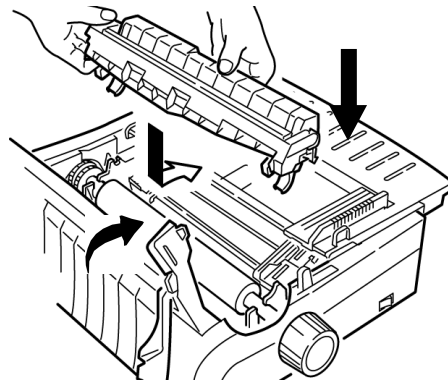

- 10 Turn the printer on and press **FF/LOAD**.

## Single-Sheet Paper Jams

- 1 Turn off the printer.
- 2 Use the platen knob to back the paper out.

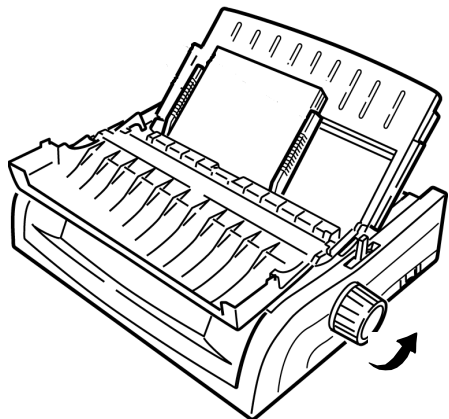

- 3 Open the access cover (1) and remove the pull-up roller assembly (2).

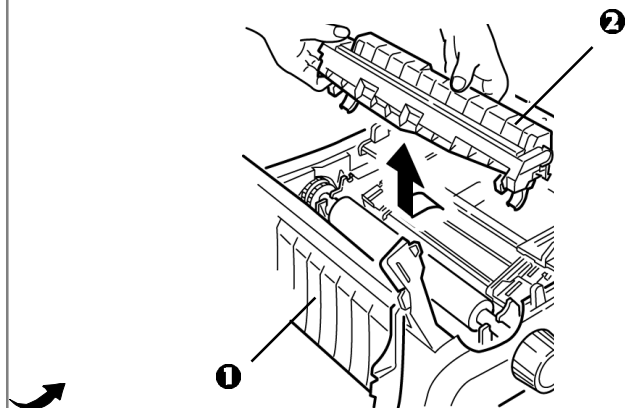

- 4 Remove any torn pieces from around the carriage.
- 5 Reinstall the pull-up roller assembly and close the access cover.

## Cleaning the Housing

You should clean the printer housing every six months (or after about 300 hours of operation).

### **CAUTION!**

*Never use strong solvents or strong detergents on the cabinet—they could damage the housing.*

- 1 Turn off the printer.
- 2 Use the platen knob to back the paper out of the printer.

### **CAUTION!**

*Make sure the printer is turned off before you open the access cover.*

- 3 Open the access cover (1) and remove the pull-up roller assembly (2).

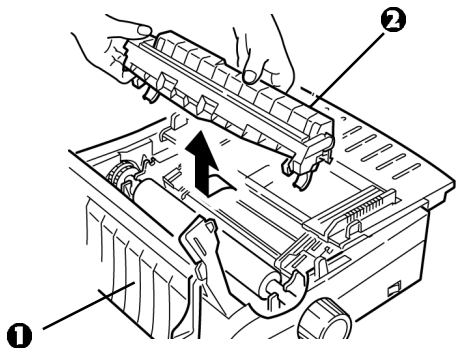

- 4 Use a clean, dry cloth to dust around the carriage shaft and platen. Remove any loose bits of paper.
- 5 Reinstall the pull-up roller assembly and close the access cover.

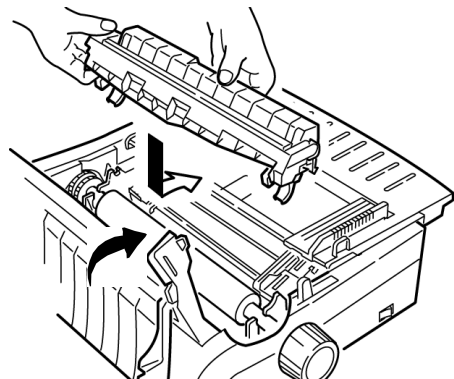

# Chapter 6: Troubleshooting

## General Information

Here are some general things to check before proceeding with detailed troubleshooting.

- Is the printer plugged in and turned on?
- Are the connections (power and interface) secure?
- Is the product being operated under the proper ambient conditions?
- Does the paper being used meet the specifications for this product?
- Is the paper properly installed?
- Is the ribbon properly installed?
- Is an Oki ribbon being used?
- Is the printhead gap correctly set?
- Are the correct printer drivers being used for the printer?

*Note: Settings in your software application will normally override any settings in your printer driver.*

*Printer driver settings normally override settings from the printer menu or printer front panel.*

# Problems / Solutions

---

## **Problem**

---

*My word processor files do not print the way I have the menu and front panel set.*

## **Solution**

Remember:

- Settings in your software application can override settings in your printer driver.
- Your printer driver settings can override any settings from the printer menu or printer front panel.

Before sending a file to the printer, many word processors send either an “initialization string” or an I-Prime signal to the printer.

The **initialization string** contains codes that override the panel and menu settings. To change your printer to ignore the reset code, enter the Menu Mode, go to the Set-Up group and change the setting for Reset Inhibit to Yes.

The **I-Prime signal** will automatically override any front panel settings you have made. To eliminate this problem, enter the Menu Mode, go to the Parallel Interface group and change the setting for I Prime to Invalid.

For more information on changing menu settings, see “Changing the Menu Settings” in Chapter 4.

---

## **Problem**

---

*Nothing happens when I turn on the printer.*

## **Solution**

Check the power cord connection to the outlet and to the printer. If you are using a power strip, make sure it is turned on, and that the fuse hasn’t blown or that the circuit breaker hasn’t tripped.

---

## ***Problem***

---

*The printer does not print when the computer sends data.*

## ***Solutions***

- 1 Is the **SEL** light on? If not, press the **SEL** key.
- 2 Check that the interface cable is securely connected to both the printer and the computer.
- 3 If you have the optional serial interface board installed, check to be sure that it is firmly seated in the printer.

---

## ***Problem***

---

*I'm getting strange symbols, incorrect fonts, etc., when I try to print a document.*

## ***Solutions***

- 1 Check to be sure that the printer driver you have selected in your software matches the printer emulation.
  - Press **SHIFT** and **SEL** keys, then press **GROUP** key.
  - This will print a line showing the emulation you have selected.
- 2 If you have embedded any printer commands in your software, check to be sure that you entered them correctly.

---

**Problem**

---

*Ink smears on the paper when I print narrow columns.*

**Solution**

This may be caused by excessive printhead travel from the centering position. Enter the Menu and set the Centering Position to MODE 1. See “Using Your Printer, Menu Mode.”

For the wide-carriage printer, if MODE 1 doesn't work, try setting the Centering Position to MODE 2.

---

**Problem**

---

*I've installed a new ribbon and the printing is smeared and streaked.*

**Solution**

The ribbon shield (1) is either loose or missing.

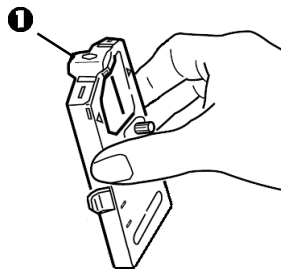

Remove the ribbon cartridge and check the ribbon shield.

- If it is loose, secure it.
- If it is missing, find it and install it.

---

**Problem**

---

*There are dots missing in my printouts.*

**Solution**

The head gap may not be set correctly. Try moving the headgap lever to a lower setting. If that doesn't help, the printhead may be damaged; call for service.

---

---

**Problem**

---

*The ALARM light is flashing.*

**Solution**

Try turning the printer off and then back on again. If the light still blinks, call for service.

---

**Problem**

---

*The ALARM light is on and the Character Pitch 10 light is flashing.*

**Solution**

This indicates that the paper lever is set at the wrong position for the paper you are trying to use. Move it to the proper setting.

---

---

**Problem**

---

*The ALARM light is on and the Character Pitch 15 light is flashing.*

**Solution**

This indicates a paper jam. Press the **SEL** key and correct the paper jam situation. See “Clearing Paper Jams,” in Chapter 4.



---

### **Problem**

---

*The printer needs paper. The ALARM is not on and I can't load paper.*

### **Solution**

- 1 Press and release the **SEL** key.
  - 2 Press and hold the **SHIFT** key and press the **RESET / CHARACTER PITCH** key.
- The **ALARM** light comes on and you can now load paper.

---

### **Problem**

---

*Continuous-form paper sticks to the sheet guide.*

### **Solution**

In cold dry weather, static charges can build up and make the paper cling to the sheet guide. Try moving the paper guides together so that the paper rests on the guides rather than on the separator.

---

### **Problem**

---

*The Print Quality and Character Pitch keys on the front panel don't work.*

### **Solution**

The Operator Panel Function in the printer menu can be used to disable these buttons (Limited Function). If the printer is part of a customized system or if it is used by a number of people, the system manager may have used this option to make sure the printer is always set properly.

Check with your system manager before changing any menu settings.

# Appendix A: Parts & Accessories

## Purchasing Parts & Accessories

Before you purchase, know your printer model number (see the front of the unit) and have the correct part number and description of the item. Item descriptions and part numbers are provided in this section.

- Consult the dealer where you purchased your printer.
- Locate an Authorized Oki Data Reseller by visiting one of our web sites

**<http://my.okidata.com>** (allows you to register your product and personalize your own support needs)

**<http://www.okidata.com>** (provides general information)

- In the United States, purchase directly from Oki Data
  - Via the Internet  
**<http://my.okidata.com>**  
**<http://www.okidata.com>**
  - Via telephone  
Order toll-free by phone at 1-800-654-3282  
(1-800-OKI-DATA) using VISA<sup>®</sup>, MasterCard<sup>®</sup>, or AmEx<sup>®</sup>.
- In Canada, call 888-309-4570.

# Replacement Parts

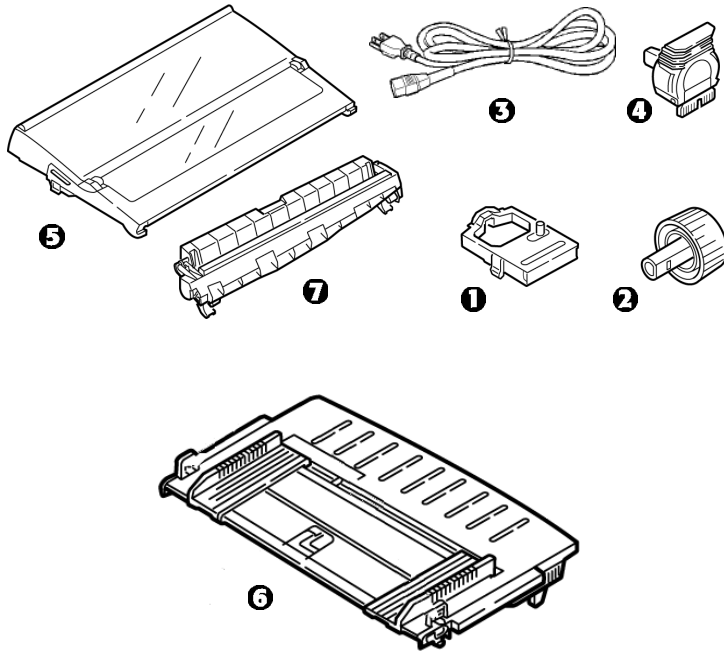

Item	Part Number
<i>Both Models</i>	
Ribbon Cartridge (1) -----	42377801
Platen Knob (2) -----	51902220
Power Cord (3) -----	56631801
Printhead (4) -----	41923901
<i>Model ML420</i>	
Access Cover (5) -----	42115401
Sheet Guide (6) -----	51009509
Pull-Up Roller Assembly (7) -----	42044701
<i>Model ML421</i>	
Access Cover (5) -----	42115301
Sheet Guide (6) -----	51009410
Pull-Up Roller Assembly (7) -----	42045701

# Accessories

## Option Part Number

### *Model ML420*

Pull Tractor, Top-Mount (1) ----- 70030501

Push Tractor, Bottom-Mount (2) ----- 70030701

Roll Paper Stand (3) ----- 70023301

### *Model ML421*

Pull Tractor, Top-Mount (1) ----- 70030601

Push Tractor, Bottom-Mount (2) ----- 70030801

### *Both Models*

Cut Sheet Feeder (4) ----- 70030101

Serial Interface (5) ----- 70012801

OkiLAN® 6120i 10/100 Base-T Ethernet  
Internal Print Server (not shown) ----- 70046501

OkiLAN 6020e 10/100 Base-T Ethernet  
External Print Server (not shown) ----- 70036001

OkiLAN 6010 10 Base-T Ethernet  
External Print Server (not shown) ----- 70034401

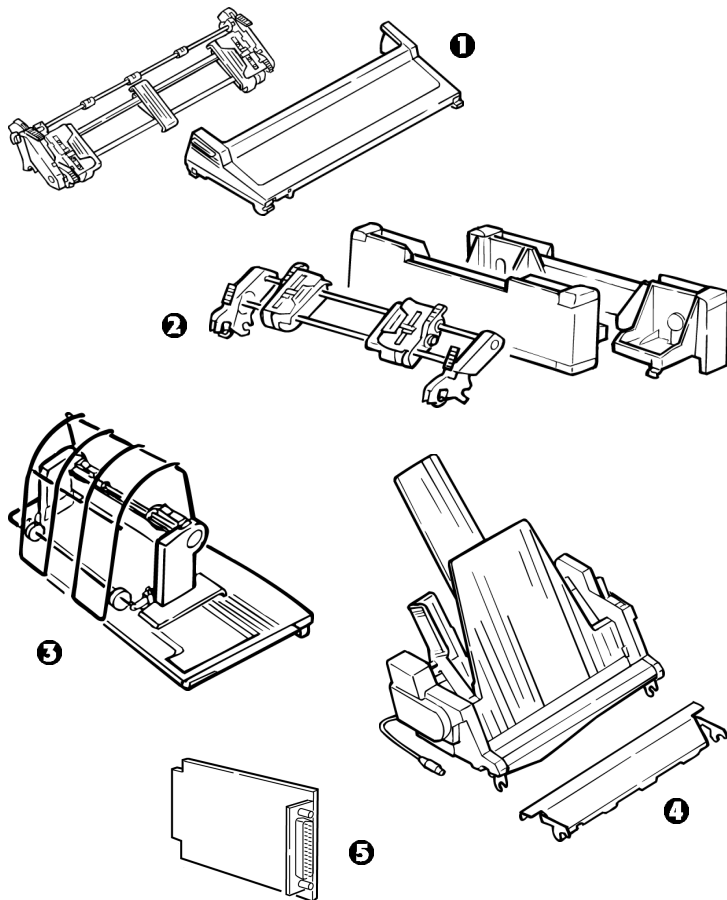

# Appendix B: Printer Control Codes

This section lists the most commonly used printer control codes.

You will find a comprehensive listing of the control codes (English only), on your Printer CD.

To access it:

- 1 Place the CD in your CD-ROM drive and wait for it to AutoPlay.
- 2 Select your printer model, then click **Continue**.
- 3 Click **Documentation** and follow the on-screen prompts to view the file.

## IBM Proprinter III Commands

IBM Command	ASCII	Decimal
Backspace	BS	8
Carriage Return	CR	13
Character Pitch		
Select 10 cpi	DC2	18
Select 12 cpi	ESC :	27 58
Select 15 cpi	ESC g	27 103
Select Condensed Print	ESC SI, or SI	27 15, or 15
Character Sets		
IBM Set I	ESC 7	27 55
IBM Set II	ESC 6	27 54
Publisher	ESC ! Z	27 33 90
Slashed Zero	ESC ! @	27 33 64
Unslashed Zero	ESC ! A	27 33 65

## IBM Proprinter III Commands (continued)

IBM Command	ASCII	Decimal
Double Width On	ESC W 1	27 87 49
Double Width Off	ESC W 0	27 87 48
Emphasized Printing On	ESC E	27 69
Emphasized Printing Off	ESC F	27 70
Enhanced Printing On	ESC G	27 71
Enhanced Printing Off	ESC H	27 72
Form Feed	FF	12
Form Length		
n inches (n = 1 to 255)	ESC C NUL n	27 67 0 n
n lines (n = 1 to 255)	ESC C n	27 67 n
Horizontal Tab, Execute	HT	9
Italics On	ESC % G	27 37 71
Italics Off	ESC % H	27 37 72

IBM Command	ASCII	Decimal
Line Feed, Execute		
w/ Carriage Return	LF	10
n/144" (n = 1 to 127)	ESC % 5 n	27 37 53 n
n/216" (n = 0 to 255)	ESC J n	27 74 n
Reverse	ESC ]	27 93
Auto Line Feed On	ESC 5 1	27 53 49
Auto Line Feed Off	ESC 5 0	27 53 48
Line Spacing		
Set Spacing to 1/8"	ESC 0	27 48
Set Spacing to 7/72"	ESC 1	27 49
Set Spacing to n/72" (n = 0 to 255)	ESC A n	27 65 n
Store Spacing Set by ESC A n	ESC 2	27 50
Set Spacing to n/144" (n = 1 to 127)	ESC % 9 n	27 37 57 n
Set Spacing to n/216" (n = 0 to 255)	ESC 3 n	27 51 n

## IBM Proprinter III Commands (continued)

IBM Command	ASCII	Decimal
Overscore On	ESC _ 1	27 95 49
Overscore Off	ESC _ 0	27 95 48
Paper Out Sensor Off	ESC 8	27 56
Paper Out Sensor On	ESC 9	27 57
Print Quality, Select HSD	ESC # 0	27 35 48
Print Suppress Mode On		
ML420	ESC Q ETX	27 81 3
ML421	ESC Q SYN	27 81 22
Print Suppress Mode Off	DC1	17
Proportional Spacing On	ESC P 1	27 80 49
Proportional Spacing Off	ESC P 0	27 80 48
Reset: Clear Print Buffer	CAN	24

IBM Command	ASCII	Decimal
Software I-Prime	ESC } NUL	27 125 0
Stop Printing	ESC j	27 106
Subscript On	ESC S 1	27 83 49
Superscript On	ESC S 0	27 83 48
Subscript/Superscript Off	ESC T	27 84
Top of Form, Set at Current Position	ESC 4	27 52
Underline Printing On	ESC - 1	27 45 49
Underline Printing Off	ESC - 0	27 45 48
Uni-Directional Print On	ESC U 1	27 85 49
Uni-Directional Print Off	ESC U 0	27 85 48
Vertical Tab, Execute	VT	11

# Epson FX Commands

<b>Epson Command</b>	<b>ASCII</b>	<b>Decimal</b>
Backspace	BS	8
Carriage Return, Execute	CR	13
Character Pitch		
Select 10 cpi	ESC P	27 80
Select 12 cpi	ESC M	27 77
Select 15 cpi	ESC g	27 103
Begin 10 cpi	ESC SI, or SI	27 15, or 15
Cancel Condensed Print	DC2	18
Delete	DEL	127

<b>Epson Command</b>	<b>ASCII</b>	<b>Decimal</b>
Double Height On	ESC w 1	27 119 49
Double Height Off	ESC w 0	27 119 48
Double Width On	ESC W 1	27 87 49
Double Width Off	ESC W 0	27 87 48
Emphasized Print On	ESC E	27 69
Emphasized Print Off	ESC F	27 70
Enhanced Print On	ESC G	27 71
Enhanced Print Off	ESC H	27 72
Epson Set 1, Select	ESC t 0	27 116 48
Epson Set 2, Select	ESC t 1	27 116 49
Italic Printing On	ESC 4	27 52
Italic Printing Off	ESC 5	27 53
Form Feed	FF	12



## Epson FX Commands (continued)

Epson Command	ASCII	Decimal
Form Length		
n Inches (n = 1 to 22)	ESC C NUL n	27 67 0 n
n Lines (n = 1 to 127)	ESC C n	27 67 n
Horizontal Tab	HT	9
Justification		
Left	ESC a 0	27 97 48
Center	ESC a 1	27 97 49
Right	ESC a 2	27 97 50
Full	ESC a 3	27 97 51
Line Feed, Execute		
Select 10 cpi	ESC P	27 80
Select 12 cpi	ESC M	27 77
w/ Carriage Return	LF	10
n/216" (n = 0 to 255)	ESC J n	27 74 n
n/144" (n = 0 to 127)	ESC % 5 n	27 37 53 n
Reverse, n/216" (n = 0 to 255)	ESC j n	27 106 n

Epson Command	ASCII	Decimal
Line Spacing, Set		
n/144" (n = 0 to 127)	ESC % 9 n	27 37 57 n
n/216" (n = 0 to 255)	ESC 3 n	27 51 n
n/72" (n = 0-85 or 128-213)	ESC A n	27 65 n
1/6"	ESC 2	27 50
1/8"	ESC 0	27 48
7/72"	ESC 1	27 49 n
Paper Out Sensor Off	ESC 8	27 56
Paper Out Sensor On	ESC 9	27 57

## Epson FX Commands (continued)

Epson Command	ASCII	Decimal
Print Quality/Font		
Select HSD/SSD (depends on setting for Draft Mode)	ESC ( 0	27 40 48
Select NLQ	ESC x 1	27 120 49
Select Courier (NLQ only)	ESC k 0	27 107 48
Select Gothic (NLQ only)	ESC k 1	27 107 49
Select UTL	ESC x 0	27 120 48
Print Speed		
Half-Speed On	ESC s 1	27 115 49
Half-Speed Off	ESC s 0	27 115 48
Print Suppress Mode On	DC3	19
Print Suppress Mode Off	DC1	17
Proportional Spacing On	ESC p 1	27 112 49
Proportional Spacing Off	ESC p 0	27 112 48

Epson Command	ASCII	Decimal
Reset Printer		
Clear Buffer & Initialize	ESC @	27 64
Clear Print Buffer	CAN	24
Skip Over Perforation, Cancel		
	ESC O	27 79
Software I-Prime	ESC } NUL	27 125 0
Subscript On	ESC S 1	27 83 49
Superscript On	ESC S 0	27 83 48
Subscript/Superscript Off	ESC T	27 84
Underline On	ESC - 1	27 45 49
Underline Off	ESC - 0	27 45 48
Uni-Directional Printing		
One Line Only	ESC <	27 60
On	ESC U 1	27 85 49
Off	ESC U 0	27 85 48
Vertical Tab, Execute	VT	11

# Oki MICROLINE Standard Commands

Oki Command	ASCII	Decimal
Backspace	BS	8
Carriage Return	CR	13
Character Pitch		
Select 10 cpi	RS	30
Select 12 cpi	FS	28
Select 15 cpi	ESC g	27 103
Select 17.1 cpi	GS	29
Select 20 cpi	ESC # 3	27 35 51
Character Sets		
Standard	ESC ! 0	27 33 48
Block Graphic	ESC ! 1	27 33 49
Line Graphics	ESC ! 2	27 33 50
Publisher	ESC ! Z	27 33 90

Oki Command	ASCII	Decimal
Slashed Zero	ESC ! @	27 33 64
Unslashed Zero	ESC ! A	27 33 65
Double Height On	ESC US 1	27 31 49
Double Height Off	ESC US 0	27 31 48
Double Width Printing	US	31
Emphasized Printing On	ESC T	27 84
Emphasized Printing Off	ESC I	27 73
Enhanced Printing On	ESC H	27 72
Enhanced Printing Off	ESC I	27 73
Form Feed	FF	12
Horizontal Tab, Execute	HT	9
Italic On	ESC ! /	27 33 47
Italic Off	ESC ! *	27 33 42

## Ok! MICROLINE Standard Commands (continued)

Ok! Command	ASCII	Decimal
Line Feed Commands		
w/ Carriage Return	LF	10
w/o Carriage Return	ESC DC2	27 18
n/144" (n = 0 to 127)	ESC % 5 n	27 37 53 n
Reverse	ESC LF	27 10
Line Spacing		
Set Spacing to 1/6"	ESC 6	27 54
Set Spacing to 1/8"	ESC 8	27 56
Set Spacing, in n/144" (n = 0 to 127)	ESC % 9 n	27 37 57 n
Skip Over Perforation		
1/3" increments (n = 1 to 9)	ESC G n n	27 71 n n
Default	ESC % S 0	27 37 83 48

Ok! Command	ASCII	Decimal
Paper Out Sensor Off	ESC E 1	27 69 49
Paper Out Sensor On	ESC E 0	27 69 48
Print Quality		
Select HSD/SSD	ESC # 0	27 35 48
Select NLQ Courier	ESC 1	27 49
Select NLQ Gothic	ESC 3	27 51
Select Utility	ESC 0	27 48
Print Speed, Set to Full		
Print Speed, Set to Half	ESC >	27 62
	ESC <	27 60
Print Suppress On		
Print Suppress Off	DC3	19
	DC1	17
Proportional Printing		
On	ESC Y	27 89
Off	ESC Z	27 90
Reset: Clear Print Buffer	CAN	24

## Oki MICROLINE Standard Commands (continued)

Oki Command	ASCII	Decimal
Shift-In	SI	15
Shift-Out	SO	14
Software I-Prime	ESC } NUL	27 125 0
Subscript Printing On	ESC L	27 76
Subscript Printing Off	ESC M	27 77
Superscript Printing On	ESC J	27 74
Superscript Printing Off	ESC K	27 75
Underline Printing On	ESC C	27 67
Underline Printing Off	ESC D	27 68
Uni-Directional Print On	ESC -	27 45
Uni-Directional Print Off	ESC =	27 61
Vertical Tab, Execute	VT	11

# Appendix C: Specifications

*Note: Specifications are subject to change without notice.*

## Print Method

Impact dot matrix

## Printhead

9 pins, 0.30 mm (0.0118") diameter, with thermal protection

## Interfaces

*Standard:* Centronics parallel, IEEE-1284 compliant  
USB 1.1

*Optional:* RS-232C Serial  
Ethernet Print Servers:  
6120i 10/100 Base-T, *Internal*  
6020e 10/100 Base-T, *External*  
6010e 10 Base-T, *External*

## Receive Buffer Size

Maximum 128K

## Reliability

### Ribbon Life

4 million characters, on average, 10 cpi utility

### Printhead Life

400 million characters average in 10 cpi utility mode at 25% duty and 35% page density

### Mean Time Between Failures (MTBF)

20,000 hours at 25% duty cycle and 35% page density

### Mean Time to Repair (MTTR)

15 minutes

## Emulations (co-resident)

- IBM Proprinter III
- Epson FX
- Oki MICROLINE Standard

## Print Speed

<b>Mode</b>	<b>Speed (Characters per Second)</b>
Super Speed Draft (SSD)	570 cps
High Speed Draft (HSD)	507 cps
Utility	380 cps
Near Letter Quality (NLQ)	95 cps

## Characters per Line (cpl)

<b>Setting</b>	<b>ML420</b>	<b>ML421</b>
10 cpi	80 cpl	136 cpl
12 cpi	96 cpl	163 cpl
15 cpi	120 cpl	204 cpl
17.1 cpi	137 cpl	233 cpl
20 cpi	160 cpl	272 cpl

## Graphics Resolution

<b>Emulation</b>	<b>Density</b>	<b>Max. Resolution (Dots per inch)</b>
IBM, Epson	Single	60 x 216 dpi
	Double	120 x 216 dpi
	Quadruple	240 x 216 dpi
Oki MICROLINE	Single	72 x 72 dpi
	Double	144 x 144 dpi
	Quadruple	288 x 144 dpi

## Resident Fonts

<b>Print Quality</b>	<b>Available Fonts</b>
Near Letter Quality	Courier, Gothic
Utility	Gothic
High Speed Draft	Gothic
Super Speed Draft	Gothic

## Bar Codes

- Code 39
- UPC A, UPC E
- EAN 8, EAN 13
- Interleaved 2 of 5
- Code 128
- Postnet

## Paper Thickness: Tractor Feed

Rear Feed: 0.014" (0.36 mm) maximum

Bottom Feed: 0.017" (0.44 mm) max.

Requires optional push or pull tractor.



## Paper Specifications: ML420

---

### Single (Cut) Sheets

---

Feed: Top Only

Weight: 14 to 24 lb. US Bond (52.6 to 90 g/m<sup>2</sup>)

Width Range: 7.2" to 8.5" (183 to 216 mm)

---

### Single-part, continuous forms

---

Feed: Rear, Bottom\*

Weight: 12 to 24 lb. US Bond (45 to 90 g/m<sup>2</sup>)

Width Range: 3" to 10" (76 to 254 mm)

---

### Carbonless continuous forms (orig. + 4 copies)

---

Feed: Rear, Bottom\*

Weight: 9 to 11 lb.

Width Range: 3" to 10" (76 to 254 mm)

---

### Interleaf continuous forms (orig. + 4 copies)

---

Feed: Rear, Bottom\*

Weight: 10 to 12 lb. paper, 9 lb carbon

Width Range: 3 to 10" (76 to 254 mm)

\* Bottom feed requires optional pull or push tractor

---

### Labels

---

Feed: Bottom\* Only

Weight: Not applicable

Width Range: 3" to 10" (76 to 254 mm)

---

### Envelopes, single feed

---

Feed: Top Only

Weight: Max. 24 lb.

Width Range: 6.5" to 9.5" (165 to 241 mm)

---

### Envelopes, continuous feed, non-overlap type

---

Feed: Bottom\* Only

Weight: Max. 24 lb.

Width Range: 6.5" to 9.5" (165 to 241 mm)

---

### Card Stock

---

Feed: Bottom\*

Weight: Max. 100 lb. Index (180 g/m<sup>2</sup>)

Width Range: Not applicable

# Paper Specifications: ML421

---

## Single (Cut) Sheet

---

Feed: Top Only

Weight: 14 to 24 lb. US Bond (52.6 to 90 g/m<sup>2</sup>)

Width Range: 7.2" to 14.3" (182.8 to 363.2 mm)

---

## Single-part, continuous forms

---

Feed: Rear, Bottom\*

Weight: 12 to 24 lb. US Bond (45 to 90 g/m<sup>2</sup>)

Width Range: 3" to 16" (76.2 to 406.4 mm)

---

## Carbonless continuous forms

---

Feed: Rear, Bottom\*

Weight: 9 to 11 lb.

Width Range: 3" to 16" (76.2 to 406.4 mm)

---

## Interleaf continuous forms

---

Feed: Rear, Bottom\*

Weight: 10 to 12 lb. paper, 9 lb. carbon

Width Range: 3" to 16" (76.2 to 406.4 mm)

---

\* Bottom feed requires optional pull or push tractor

---

## Labels

---

Feed: Bottom\* Only

Weight: Not applicable

Width Range: 3" to 16" (76.2 to 406.4 mm)

---

## Envelopes, single feed

---

Feed: Top Only

Weight: Max. 24 lb.

Width Range: 6.5" to 9.5" (165.1 to 241.3 mm)

---

## Envelopes, continuous feed, non-overlap

---

Feed: Bottom\* Only

Weight: Max. 24 lb.

Width Range: 6.5" to 9.5" (165.1 to 241.3 mm)

---

## Card stock

---

Feed: Bottom\* Only

Weight: Max. 100 lb. Index (180 g/m<sup>2</sup>)

Width Range: Not applicable

---

## Environmental Requirements

### Temperature

Operating: 41 to 95°F (5 to 36°C)

Storage: 14 to 122°F (-10 to 50°C)

### Humidity

Operating: 20 to 80% RH

Storage: 5 to 95% RH

## Electrical Requirements

- 120 volts ac, (+6%, -15%)  
50 or 60 Hz ( $\pm 2\%$ )  
58 W Typical, 10 W idle
- 230 ac, (+15%, -14 %)  
50 or 60 Hz ( $\pm 2\%$ )  
58 W Typical, 10 W idle

## Physical Specifications

*Note: Height dimensions do not include the acoustic cover.*

### ML420

Size (WxDxH): 17.1" x 16.1" x 6"  
(434 x 409 x 153 mm)

Weight: 16.7 lbs. (7.6 kg)

### ML421

Size (WxDxH): 23.1" x 16.1" x 6"  
(588 x 409 x 153 mm)

Weight: 21.1 lbs. (9.6 kg)

# Appendix D: Installation

## Location

- Place your printer on a firm, solid surface.
- Allow enough space around the printer to easily access the platen knob and the various paper feed paths.
- Make sure a suitable grounded power outlet is available nearby.

## Unpack

- If any items are missing, contact your dealer immediately.
- Keep your packing materials and carton in case you ever need to ship or transport the printer.
- Interface cable and paper are sold separately.

- 1 Printer
- 2 Ribbon Cartridge
- 3 Power Cord

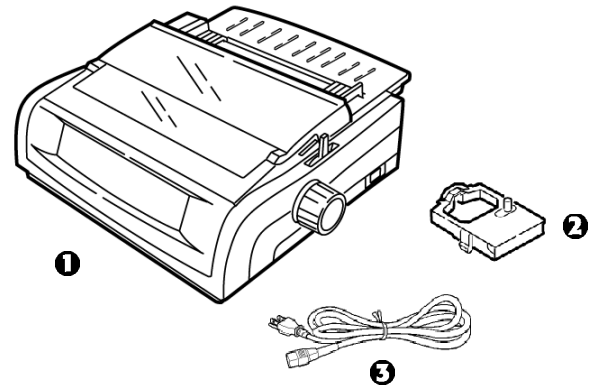

- 1 Remove any packing tape, then grasp the tabs (1) at either end of the access cover and pivot it toward the front of the printer as far as it will go.

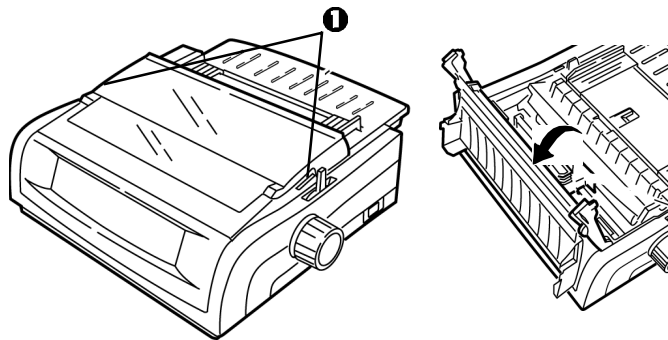

- 2 Remove the printhead shipping restraint.

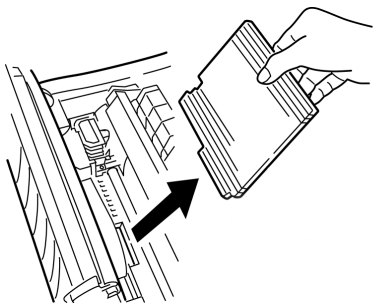

- 3 Remove the shipping restraint from the pull-up roller assembly (1).

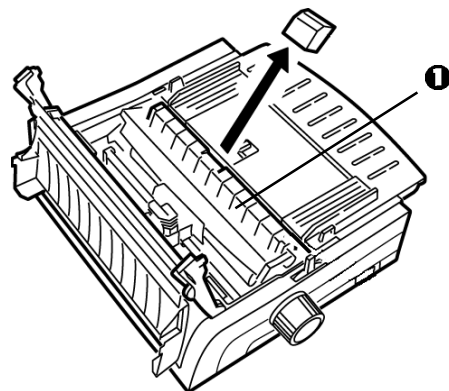

- 4 Use the tabs (1) to lift and remove the sheet guide, then remove the shipping restraint.

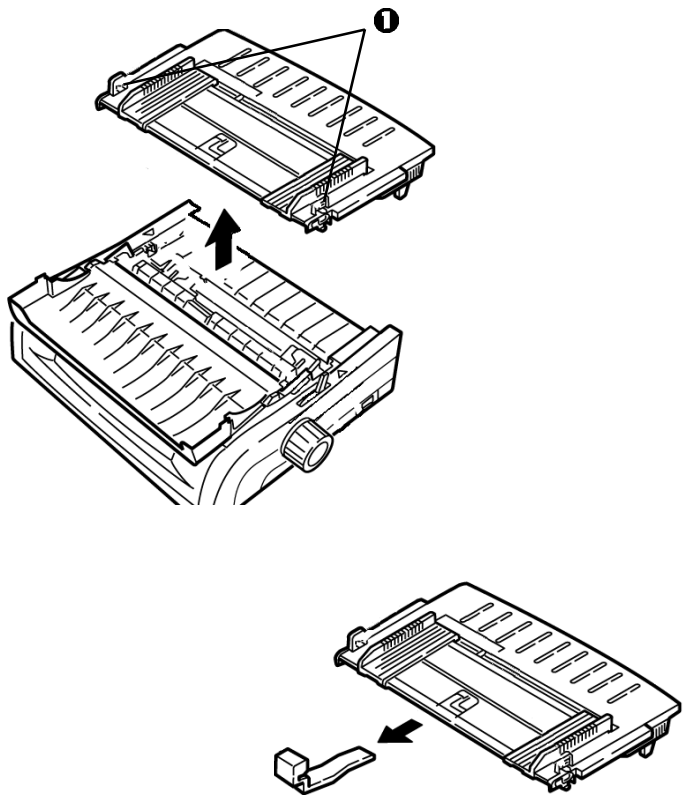

- 5 Reinstall the sheet guide: insert the clips on either side of the separator into the notches marked with a triangle, then press down to secure the separator in place.

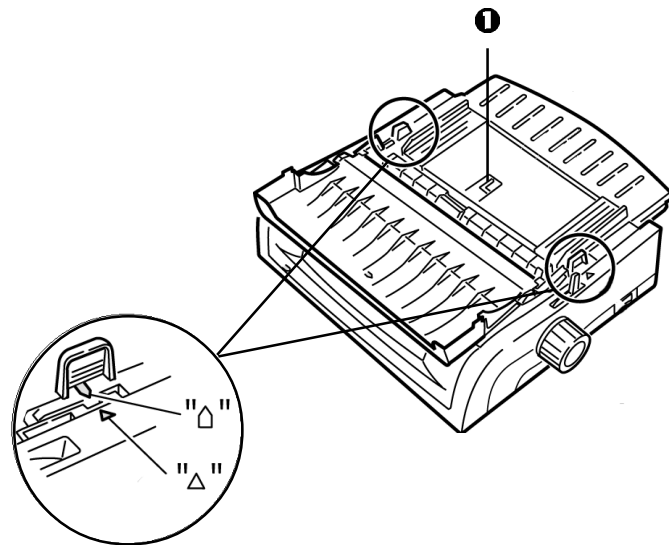

## Install the Ribbon Cartridge

### **Important!**

*Make sure you have the correct replacement ribbon for your printer. The wrong ribbon will not print when installed in your printer.*

### **Ribbon Cartridge Handling**

- Leave unused ribbon cartridges in their packages until needed.
- Careful; the ribbon ink may cause permanent stains.
- Ribbon ink on skin or clothing can usually be removed with soap and water.

**1** *Make sure the printer is turned OFF.*

**2** Open the access cover and center the printhead (1).

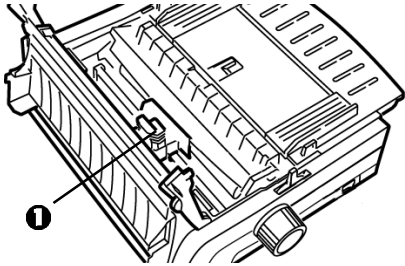

**CAUTION! The printhead may be HOT!**

**3** Unpack the new ribbon cartridge and install it on the printhead.

### **Important!**

*Do not remove the ribbon shield (1) from the ribbon!*

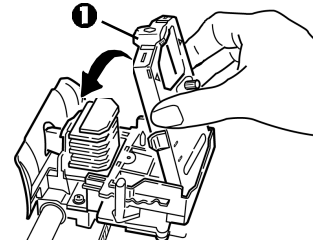

**4** Turn the take-up knob (1) in the direction of the molded-in arrow to take up any ribbon slack.

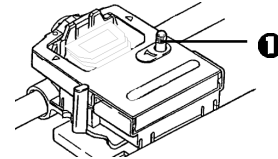

**5** Close the access cover and turn the printer on.

## Power Connection

- 1 *Make sure both the printer and the computer are OFF.*
- 2 Plug the power cord into the back of the printer, then into a grounded outlet.

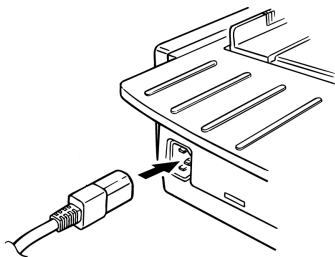

- 3 Turn on the printer.

## Computer Connections

### Parallel (LPT): IEEE 1284

- Requires bidirectional cable, max. length 6 ft. (1.8 m), not supplied.
- Printer has 36-pin socket

- 1 Make sure the printer and computer are both turned *off*.
- 2 Attach a suitable *bidirectional* cable to the parallel connector on the back of the printer. Then attach and secure the cable to your computer.

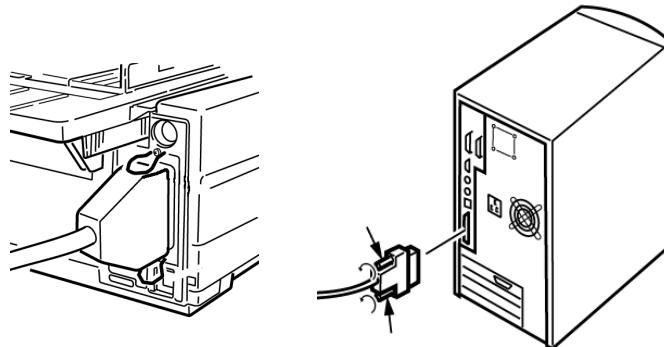

- 3 Turn the printer and computer back on.



## USB: Specification 1.1 Compliant

- Requires USB 1.1 cable, maximum length 19.7 ft. (5 m), not supplied.
  - Printer has USB “B” receptacle.
- 1 Make sure the printer and computer are both turned *off*.
  - 2 Attach a suitable USB cable to the printer. Then attach the cable to your computer.

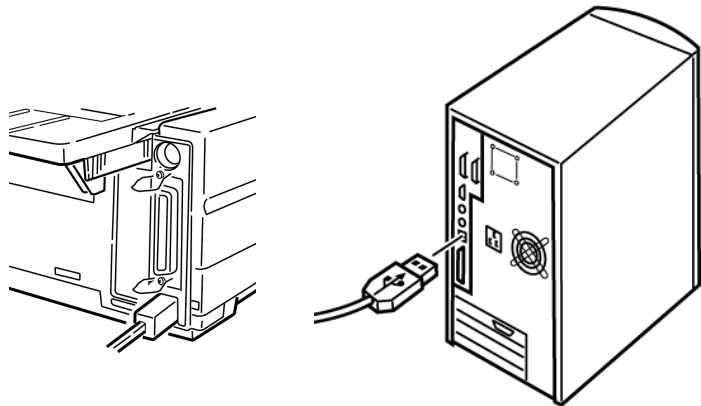

- 3 Turn the computer and printer back on.

## Loading Paper

For instructions on loading paper, see “Loading Paper” in Chapter 5.

# Testing the Printer

- Font Sample Test
- Rolling ASCII Test
- Hexadecimal Dump Mode

## Font Sample Test

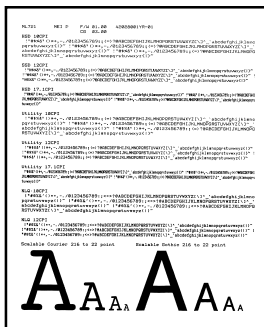

### **Important!**

***Wide carriage Model ML421:*** If you are using 8.5" paper to run the tests, make sure the paper width selection in the printer menu is set to 8.5 inches. Otherwise, printing on the platen may damage the printer. See Chapter 4: Menu Mode for more information.

The Font Sample Test prints a sample of the fonts standard to the printer.

The top of the printout shows the Printer Model, Emulation, Country Code, Interface, and Firmware Revision Level.

- 1 Make sure paper is loaded.
- 2 Turn off the printer.
- 3 Press and hold the **LF** key while turning the printer back on.

*The printer prints a page of font samples and the test ends.*

## Rolling ASCII Test

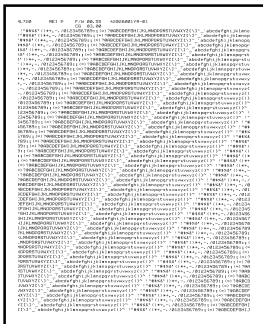

### ***Important!***

***Wide carriage Model ML421: If you are using 8.5" paper to run the tests, make sure the paper width selection in the printer menu is set to 8.5 inches. Otherwise, printing on the platen may damage the printer. See Chapter 4: Menu Mode for more information.***

The Rolling ASCII Print Test produces a continuous printout of all 96 ASCII characters in a rolling pattern in whatever typeface is selected (default = LQ Courier).

The top of the printout shows the Printer Model, Emulation, Country Code, and Firmware Revision Level.

- 1 Make sure continuous forms paper is loaded.
- 2 Turn the printer off.
- 3 Press and hold the **QUIET/TOF** key while turning the printer back on. (If the printer comes on without starting the Rolling ASCII test print, you did not hold the QUIET/TOF key long enough.)  
*The printer prints the rolling ASCII text page after page.*
- 4 Press **SEL** to end the test.

## Hexadecimal Dump Mode

When the printer is placed in the Hexadecimal Dump Mode, all data received, including text and printer commands, is printed in both hexadecimal and ASCII format.

For example, the following line of BASIC code

```
LPRINT CHR$( 27);"0";CHR$( 30);"This is an  
example of a hexadecimal dump."
```

would print like this:

```
1B 30 1E 54 68 69 73 20 69 73 20 61 6E 20 65 78 .0.This is an ex  
61 6D 70 6C 65 20 6F 66 20 61 20 68 65 78 61 64 ample of a hexad  
65 63 69 6D 61 6C 20 64 75 6D 70 2E 0D 0A ecimal dump...
```

*Note: In the ASCII format, all non-printable characters are represented by a period.*

To engage the Hexadecimal Dump Mode:

- 1 Make sure paper is loaded.
- 2 Turn off the printer.
- 3 Hold the **SEL** and **FF/LOAD** keys for several seconds while turning on the printer.

To exit the Hexadecimal Dump Mode:

- Press the **SEL** key.  
*or*
- Turn the printer off, then on again.

## Emulations

The factory default emulation for your printer is IBM Proprinter III.

If you wish to change to one of the other emulations, see “Changing Emulations” in Chapter 3.

## Printer Drivers

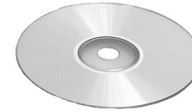

The Oki driver for your printer is provided on the CD included with the printer. You can either load the Oki driver or select one of the compatible drivers listed below in your software application.

## Loading the OKI Driver

### Parallel Interface

1 Insert the CD into your CD-ROM drive.

*Note: If the CD does not AutoPlay, click Start → Run → Browse, then browse to your CD-ROM drive, double-click Install.exe and click OK.*

2 Select your printer model.

3 When the Menu Installer window appears, click the **Printer Software** button.

4 Follow the on-screen instructions.

### USB Interface

1 Turn the printer on.

*The Windows Add New Hardware Wizard window displays.*

2 Click **Next**.

3 Insert the CD into your CD-ROM drive.

4 Follow the on-screen instructions to install the software for your printer model.

## Using a Compatible Driver

*Note: See your software documentation for information on how to select a printer driver.*

The drivers below are listed by **decreasing** compatibility with your printer. Use one as close to the top of the list as possible.

### IBM Proprinter III

- IBM Proprinter III
- IBM Proprinter II
- IBM Proprinter

### Epson FX

- Epson FX286e
- Epson FX 850/1050
- Epson FX 800/1000

# Index

## A

Accessories .....	68
Alignment problems .....	9
ASCII Test .....	91
Auto Carriage return .....	35
Auto LF (Line Feed) .....	31, 35
Auto Select .....	32

## B

Bar Codes .....	80
Bi-directional printing .....	30, 40
Bottom Feed .....	81, 82
Form Tear-Off .....	29
Line Spacing .....	29
Skip Over Perforation .....	29
Buffer	
Clearing .....	38
Receive Buffer Size .....	78

## C

Carbonless continuous forms .....	81, 82
Card Stock .....	81, 82
Centering printhead position .....	63
Character Pitch .....	39
Selecting .....	23
Character Set .....	28, 36
Character Width .....	39
Characters Per Second (CPS) .....	7
Code Page Character Set .....	36
Codes, Printer Control .....	69
Commands	
Epson FX .....	72–74
IBM Proprinter III .....	69–71
Okidata Microline Standard .....	75–77
Control Codes .....	69
Cut Sheet Feeder .....	68

## E

Electrical Requirements .....	83
Emulations .....	24, 92
Mode .....	37
Envelopes .....	81, 82
Environmental Requirements .....	83
Epson FX Commands .....	72–74

## F

Factory defaults, menu mode .....	26
Font Sample Test .....	90
Fonts	
Embedded Printer Commands .....	62
Resident .....	80
Selecting .....	40
Forms Tear-Off .....	37
Changing .....	18
Top of Form .....	12, 17
Wait Time .....	41
Front Panel	
Keys .....	9
Menu Mode .....	25

## G

Graphics	
Printing .....	30, 37
Resolution .....	80
GROUP, Menu Mode .....	25

## H

Height, Double Height Printing .....	41
Hex Dump Mode .....	92
Humidity .....	83

## I

I-Prime .....	32, 38, 61
IBM	
Character Set .....	36
Proprinter III Commands .....	69–71
Initialization string .....	61
Interleaf Continuous Forms .....	82
Interleaf continuous forms .....	81
Interleaved 2 of 5 .....	80
Italics .....	28, 41

## L

Labels .....	81, 82
Language .....	28
Length, Page	
Rear Feed .....	29
Top Feed .....	30
Limited Operation .....	9, 38, 65
Line Spacing .....	38
Bottom Feed .....	29
Rear Feed .....	29
Top Feed .....	30

## M

Margin, Bottom .....	30, 36
Mean Time Between Failures (MTBF) ..	78
Mean Time to Repair (MTTR) .....	78
Memory, Receive Buffer Size .....	78
MENU light .....	25
Menu Mode .....	25
Changing Settings .....	27
Entering .....	26
Exiting .....	26
Front Panel keys .....	25
Printing the Menu Settings .....	26
Reset to factory defaults .....	26
Settings Table .....	28–42

## O

Okii MICROLINE Standard	
Commands .....	75–77
Operator Panel Function .....	65
Options .....	66

## P

Page Length	
Rear Feed .....	29
Top Feed .....	30
Page Width .....	39
Bottom Feed .....	29
Rear Feed .....	29
Setting in the Printer Menu .....	30, 39
Top Feed .....	30
Paper	
Cut Sheet .....	68
Single Sheet .....	53
Static .....	65
Thickness .....	80
Weight .....	82
Widths .....	30, 39, 82
Paper Jams .....	64–66
Paper Lever .....	64
Paper Out .....	65
Override .....	30, 39

Paper Park .....	18
Paper Path, switching .....	19
Parallel Interface .....	32
I-PRIME Signal .....	61
Parts, replacement, purchasing .....	66
Perforation, skip over .....	29, 41
Pitch, character .....	28, 39
PlatenKnob part number .....	67
Postnet .....	80
Power rating .....	3
Print Method .....	78
Print Mode .....	28, 40
Print Registration .....	31, 40
Print Server Option .....	68
Print Size .....	79
Print Speed .....	7, 79
Print Suppress .....	31, 40
Printer Control Codes .....	69–77
Printer Drivers, Selecting .....	92–93
Printer Parameters .....	25
Printhead .....	78
Gap .....	21
Proportional Spacing .....	28, 40
Pull Tractor .....	68
Push Tractor .....	68

## R

Rear Feed	
Continuous Forms .....	10
Form Tear-Off .....	29, 30
Jams, Repetitive .....	56
Line Spacing .....	29
Paper Jam .....	55
Skip Over Perforation .....	29
Receive Buffer Size .....	78
Reliability .....	78
Replacement Parts .....	66
Resolution (Graphics) .....	80
Ribbon Cartridge	
Replacement Order No. ....	67
Replacing .....	42
Ribbon Shield .....	43, 63, 87
Roll Paper Stand .....	68
RS-232C Serial Interface .....	78



## S

Self Tests .....	90
Serial Interface .....	68
Serial Interface Option .....	62
Server, Print Option .....	68
Sheet Guide .....	67
Single Sheet	
Cut Sheet Feeder Option .....	68
Jams .....	58
Loading .....	53
Skip Over Perforation .....	29
Software	
Embedded commands .....	62
Matching drivers to emulations .....	62
Software vs. printer settings .....	61
Specifications .....	78
Standard Character Set .....	28
Symbol Sets .....	28, 38

## T

Temperature Specifications .....	83
Tests	
ASCII Test .....	91
Font Sample Test .....	90
Hex Dump .....	92
Thickness, Paper .....	80
Time Out .....	32, 41
Top Feed .....	81–84
Bottom Margin .....	30
Line Spacing .....	30
Pull Tractor .....	68
Single Sheet .....	11
Top of Form .....	35
Forms Tear-Off .....	8, 12, 17
Paper Shield .....	9, 12
Reset to factory default .....	16
Setting .....	12
Standard Setting .....	12, 16
Typefaces .....	28
Selecting .....	40

## U

Uni-directional printing, graphics .....	30
Utility	
Front Panel Light .....	80
Print Speeds .....	7
Utility Mode Print Quality .....	22

## W

Wait Time .....	30, 41
Weight, Paper .....	82
Width	
Character .....	39
Double width printing .....	41
Page	
Bottom Feed .....	29
Rear Feed .....	29
Top Feed .....	30
Paper .....	82
Setting in the Printer Menu ....	30, 39

## Z

Zero character (slashed, unslashed) .	28, 41
---------------------------------------	--------