

# tennsco

## SERVICE CART ASSEMBLY

1. Bolt lower tray (Ref. No. 2) to four post (Ref. No. 3) with sixteen 1/4-20 bolts and nuts.
2. Bolt upper tray (Ref. No. 1) to post with twelve bolts and nuts. Do not insert two bolts in each side (Position A) until ready to attach handle brackets (Ref. No. 7).
3. Place caster support (Ref No. 4) between lower tray and caster top plates and secure with 1/4-20 bolts and nuts. Caster position optional.
4. Attach one handle bracket (Ref. No. 7) at Position A, bolting through post, bracket and upper tray.
5. Assemble tubular handle (Ref. No. 8) over embossed section of bracket. (See Detail No. 1)
6. Place second handle bracket into handle and bolt to posts.
7. Check assembly for squareness and tighten all bolts and nuts.

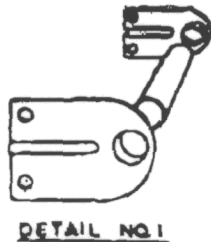
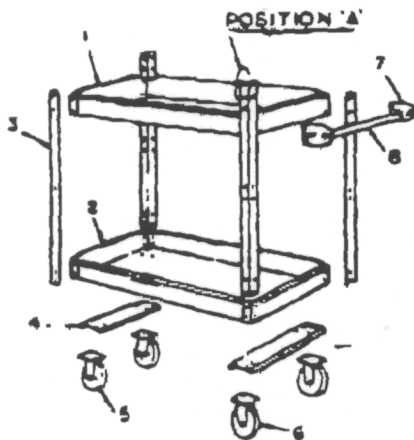

<u>ITEM</u>	<u>DESCRIPTION</u>	<u>AMT.</u>
1	Upper Tray	1
2	Lower Tray	1
3	Upright Post	4
4	Caster Support	2
5	Rigid Caster	2
6	Swivel Caster	2
7	Handle Bracket	2
8	Handle	1
9	1/4-20 x 1/2 Bolt	48
10	1/4-20 Ctr. Lk. Hex Nut	48