

ASSEMBLY INSTRUCTIONS

Sort and count your parts!

PARTS LIST			
LETTER CODE	DESCRIPTION	QTY.	PART NO.
(A)	Leveling Glide	4	1853-25
(B)	Swivel Base	1	1853-05
(C)	Screw Post	24	HFFMFB
(D)	Locking Cam	24	HFFMFC
(E)	Side Panel	2	1853-02
(F)	Top Panel	1	1853-01
(G)	Divider	2	1853-06
(H)	Upper Shelf	1	1853-08
(I)	Lower Shelf	1	1853-09
(J)	Wire Paper Stop	2	1853-10

TOOLS REQUIRED: Phillips Screwdriver
(two people recommended for assembly)

ASSEMBLED UNIT
MODEL 1853

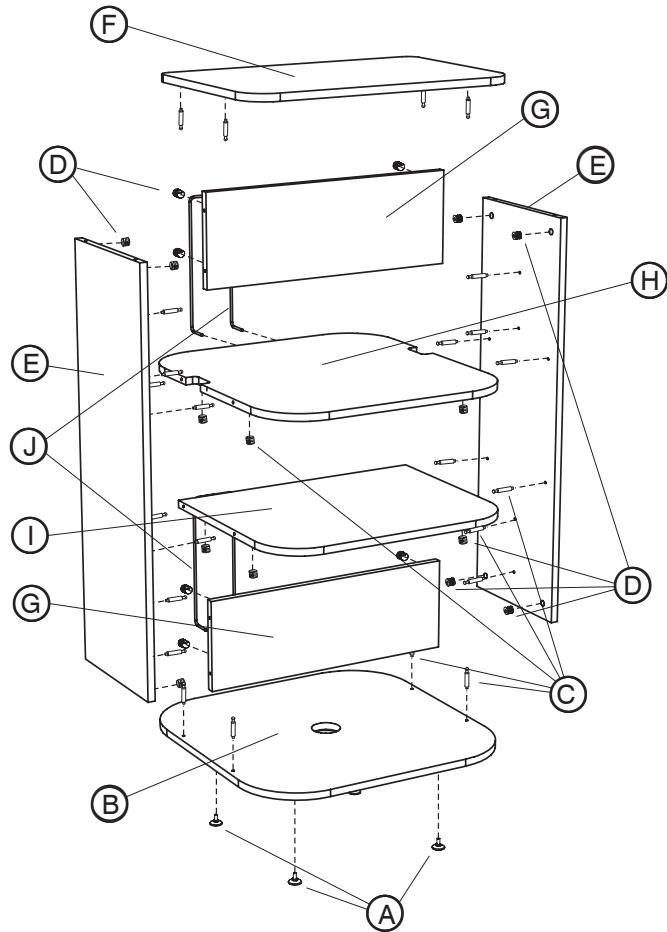

For questions or concerns, please call

Safco Consumer Hot Line 1-800-664-0042

available Monday-Friday 8:00 AM to 4:30 PM (Central Time)
(English-speaking operators)

- 1** Screw four (A) Leveling Glides into the sockets on the underside of the (B) Swivel Base, as shown.

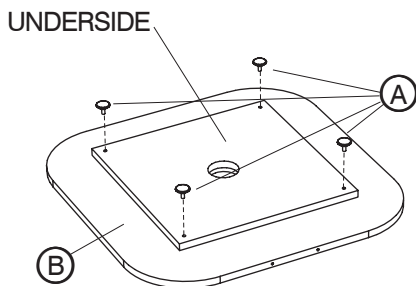

- 2** Turn the Swivel Base upright, and screw four (C) Screw Posts into the small holes on the top side, but do not overtighten.

Insert four (D) Locking Cams into each of the large holes of each (E) Side Panel, with the arrows on the Cams pointing to the outer edges. Insert eight (C) Screw Posts into the smaller holes on each Side Panel, but do not overtighten.

NOTE: The TOP edge of each Side Panel has a greater distance to the holes along the centerline than does the bottom edge (see illustration).

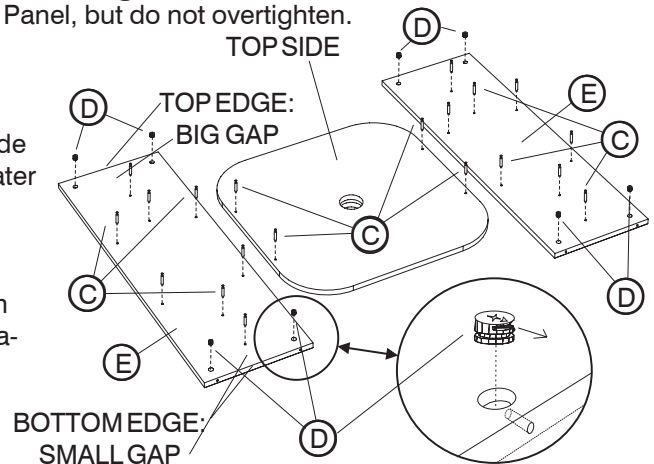

- 3** Insert four **C** Screw Posts into the holes of the **F** Top Panel.

Insert four **D** Locking Cams into the large holes on each of the following: the two **G** Dividers, the **H** Upper Shelf, and the **I** Lower Shelf.

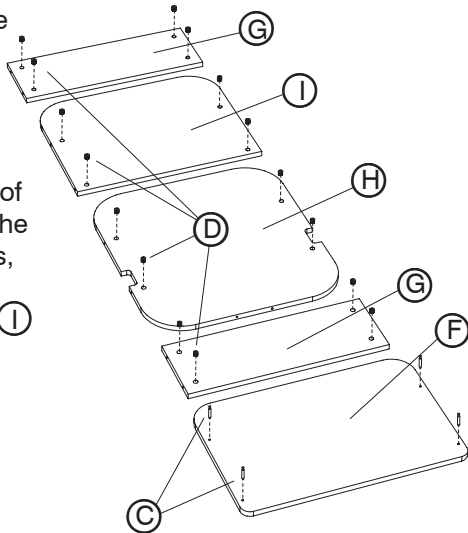

- 4** Attach one **G** Divider to the Side Panel, sliding the Screw Posts into place and turning the two engaged Cams clockwise until they stop, to lock in place. Now attach the **H** Upper Shelf, the **I** Lower Shelf, and the other Divider to the Side Panel in the same manner.

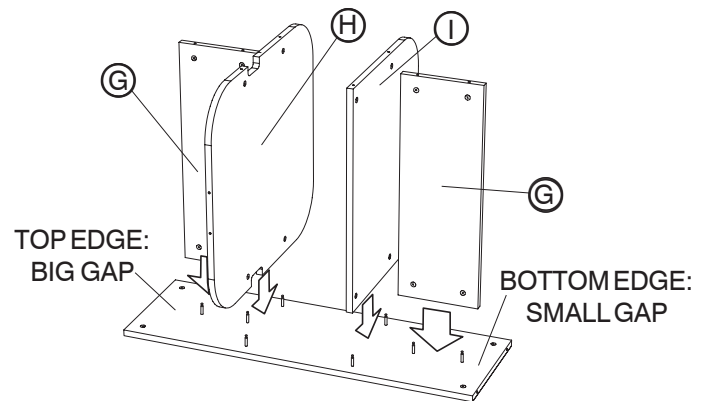

- 5** Place the remaining **E** Side Panel over the assembly, and line up all Screw Posts with their corresponding holes. Press into place, and lock all engaged Cams.

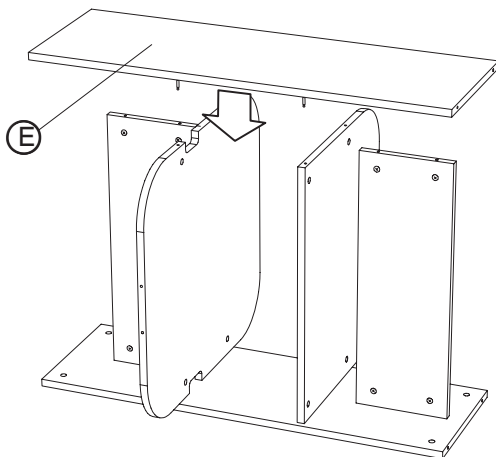

- 6** Carefully place the assembly over the **B** Swivel Base, so the Screw Posts enter the matching holes in the bottoms of the Side Panels. Lock all four Cams.

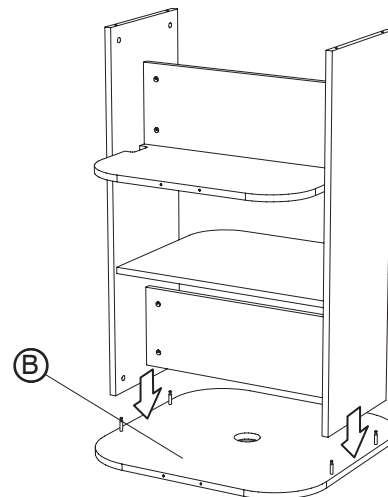

- 7** Place the **F** Top Panel in the same manner, and lock all Cams as before.

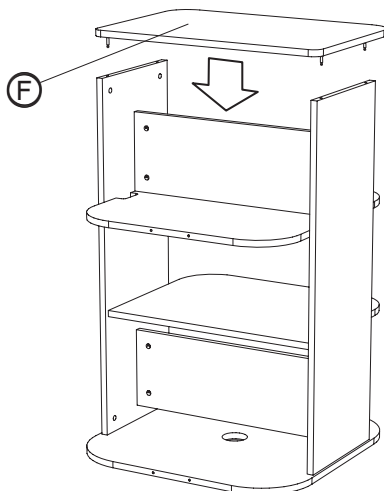

- 8** Press the two **J** Wire Paper Stops into the holes on the back edges of the Upper Shelf and the Swivel Base to complete the assembly.

