





K  Lock Catch 1 Set	L  Lockset 1 Set	M  Screw 3.5*20 4 PCS	N  Hinge 2 PCS	O  Screw 4*16 12 + 2 extra PCS
---------------------------------------------------------------------------------------------------------------------	-------------------------------------------------------------------------------------------------------------------	------------------------------------------------------------------------------------------------------------------------	-----------------------------------------------------------------------------------------------------------------	---------------------------------------------------------------------------------------------------------------------------------

STEP 1

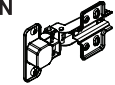

STEP 2

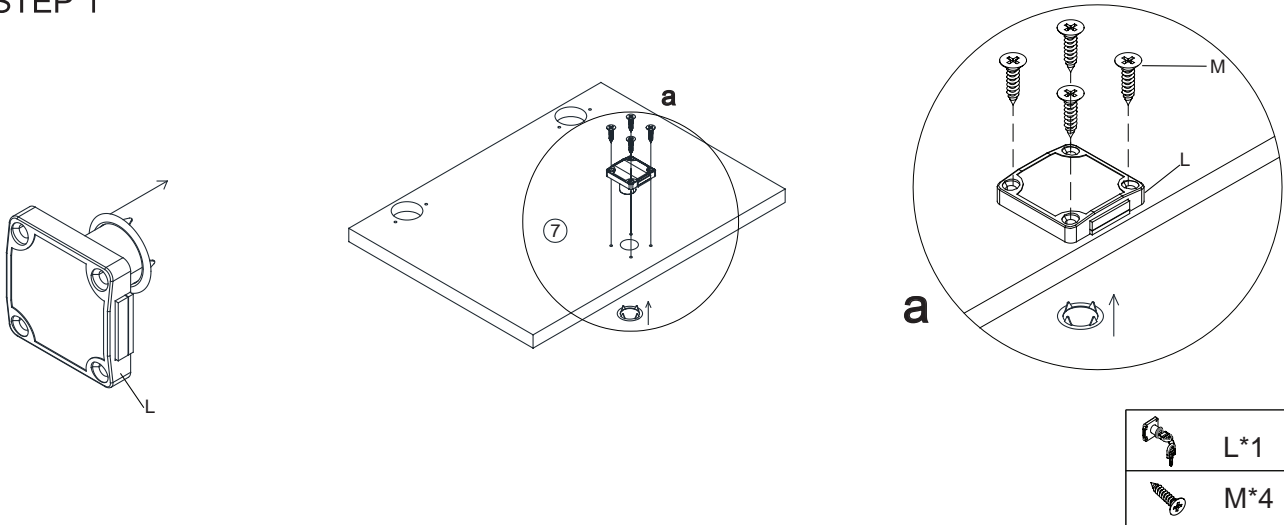
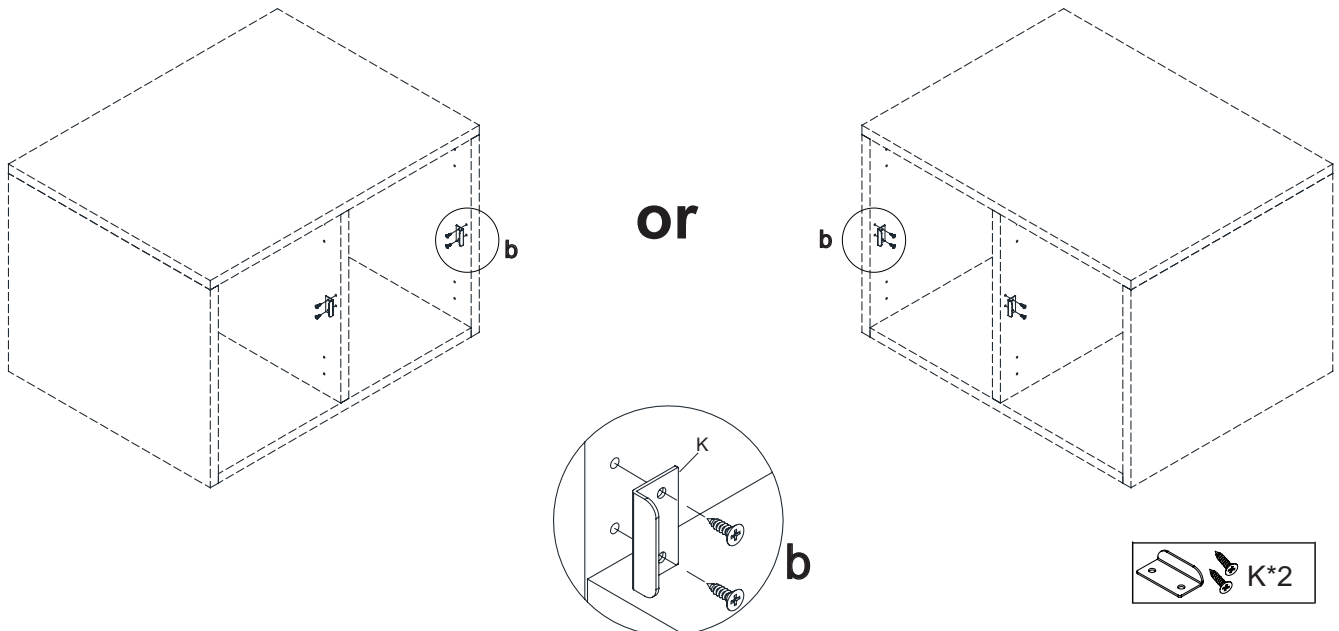

IMPORTANT NOTE:

- Place all laminated parts and glass top on a clean and smooth surface such as a rug or carpet to avoid the parts from being scratched.
- Check to make sure that you have all parts and hardware.
- Remove all wrapping materials, including staples and packaging straps before you start to assemble.
- Do not tighten all screws/bolts until pieces are completely assembled.
- Keep all hardware parts out of children's reach.
- It is recommended for 2 persons to complete this assembly.



STEP 3

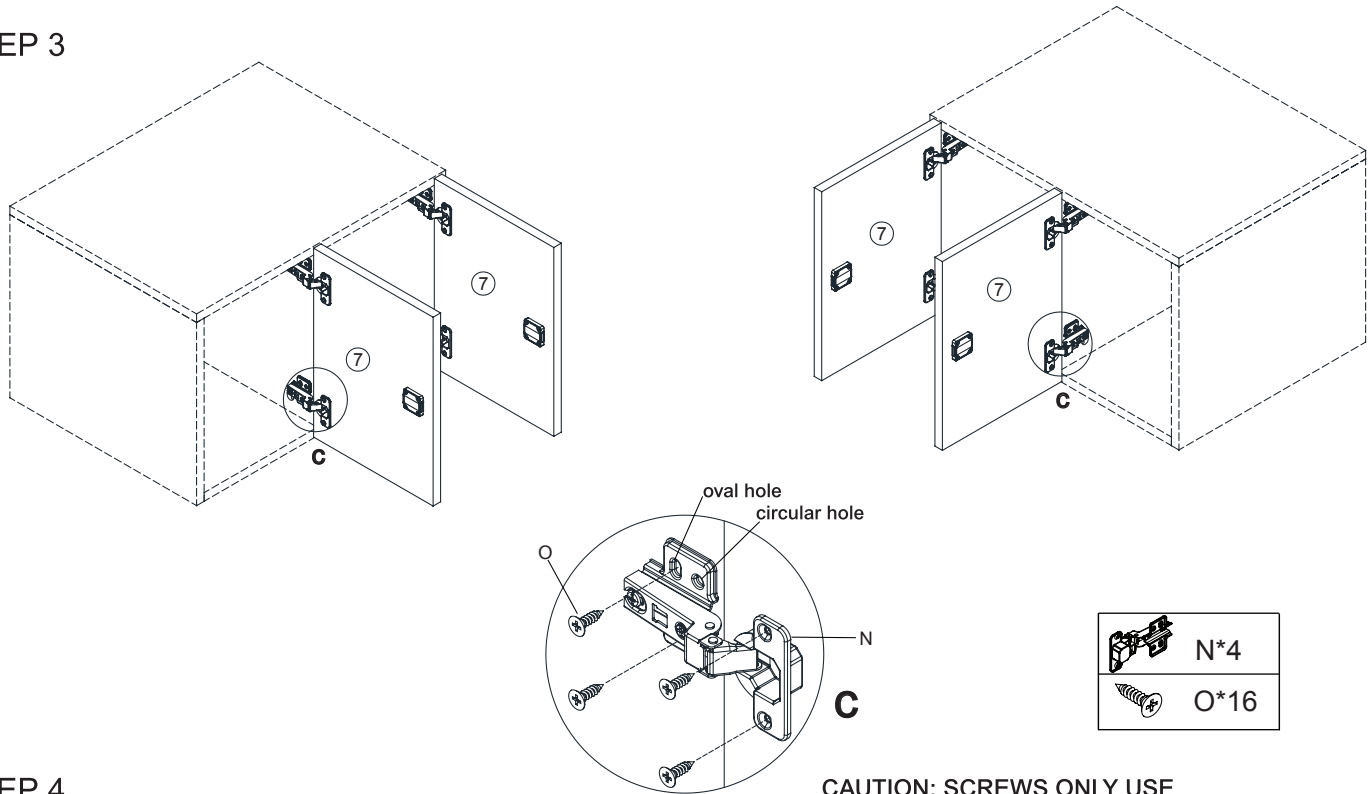

STEP 4

CAUTION: SCREWS ONLY USE OVAL HOLE AT THIS STEP.

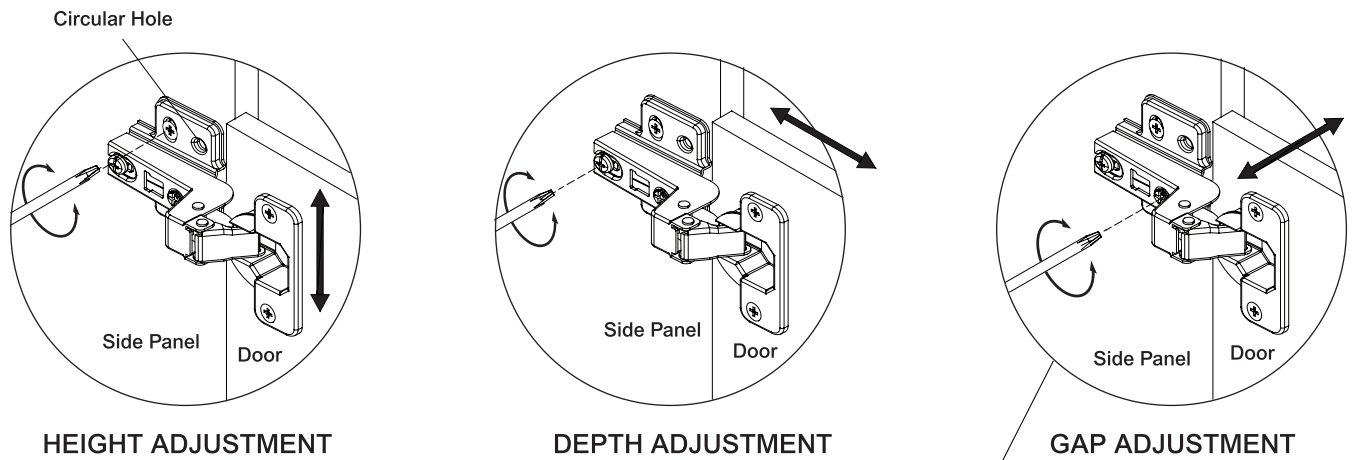

HEIGHT ADJUSTMENT

When adjustment height is OK, then use screw O to fix the hinge in the circular hole.

DEPTH ADJUSTMENT

GAP ADJUSTMENT

 If the door cannot be locked, tight this screw to adjust the door.

IMPORTANT NOTE:

- Place all laminated parts and glass top on a clean and smooth surface such as a rug or carpet to avoid the parts from being scratched.
- Check to make sure that you have all parts and hardware.
- Remove all wrapping materials, including staples and packaging straps before you start to assemble.
- Do not tighten all screws/bolts until pieces are completely assembled.
- Keep all hardware parts out of children's reach.
- It is recommended for 2 persons to complete this assembly.

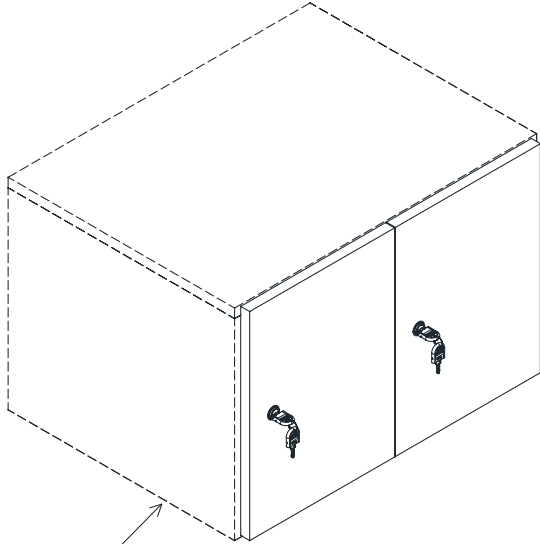

TWO PEOPLE ARE REQUIRED TO ASSEMBLE AND MOVE THIS MODEL

COMPLETED ASSEMBLY

Double Open Locker Adder
LLR42403

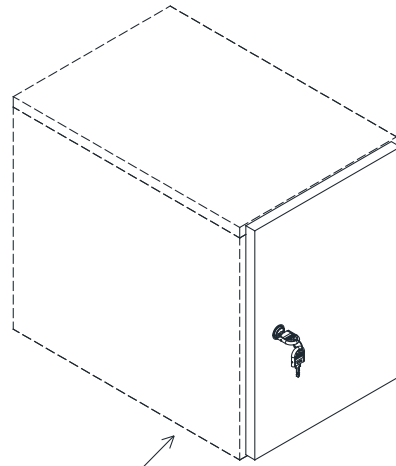

Single Open Locker Adder
LLR42402

IMPORTANT NOTE:

- Place all laminated parts and glass top on a clean and smooth surface such as a rug or carpet to avoid the parts from being scratched.
- Check to make sure that you have all parts and hardware.
- Remove all wrapping materials, including staples and packaging straps before you start to assemble.
- Do not tighten all screws/bolts until pieces are completely assembled.
- Keep all hardware parts out of children's reach.
- It is recommended for 2 persons to complete this assembly.



TWO PEOPLE ARE REQUIRED TO
ASSEMBLE AND MOVE THIS MODEL

K Gâche x1	L Verrou x1	M Vis 3.5*20 x4	N Charnière x2	O Vis 4*16 x12 + 2 extra
-----------------------------	------------------------------	----------------------------------	---------------------------------	-------------------------------------------

ÉTAPE 1

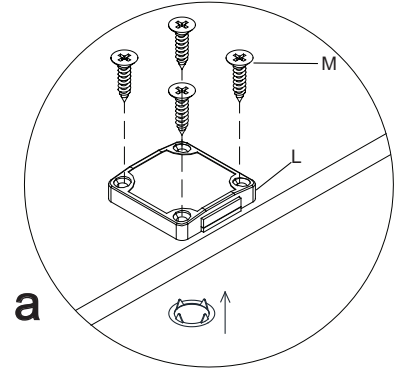
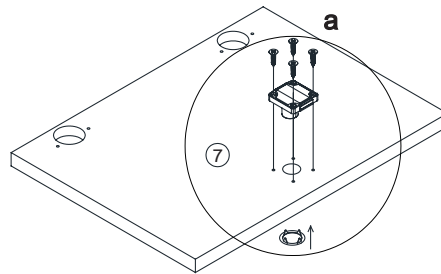
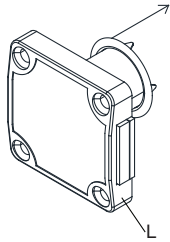

	L*1
	M*4

ÉTAPE 2

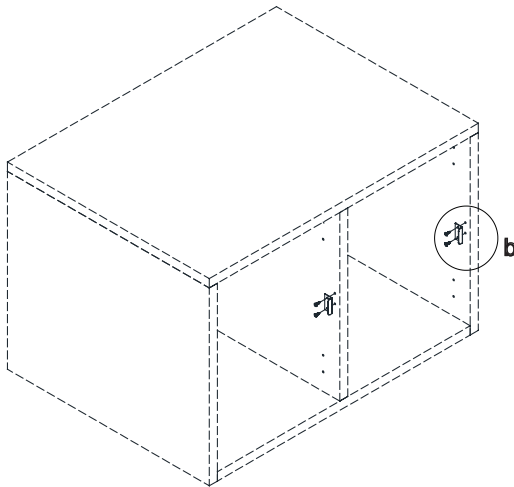

ou

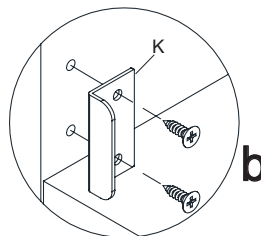
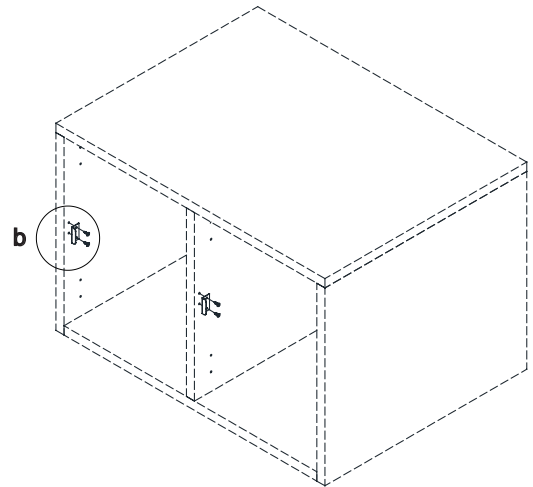

	K*2
--	-----

NOTE IMPORTANTE :

- Déposez les pièces en mélamine et le plateau de verre sur une surface en tissu (nappe ou tapis) afin d'éviter de les égratigner.
- Vérifiez pour vous assurer que vous avez toutes les pièces et toute la quincaillerie.
- Enlevez tout le matériel d'emballage, incluant les agrafes et les courroies d'emballage avant de débuter l'assemblage.
- Ne serrez pas aucun des boulons/vis avant d'avoir assemblé toutes les pièces.
- Gardez toutes les pièces de quincaillerie hors de portée des enfants.
- Il est recommandé que 2 personnes effectuent cet assemblage.



2 personnes sont requises pour l'assemblage et le déplacement de ce modèle.

ÉTAPE 3

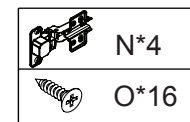
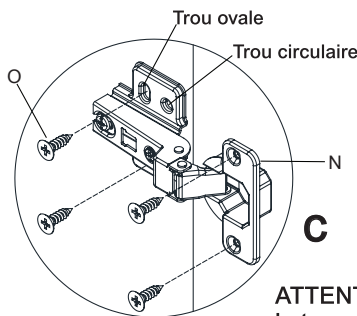
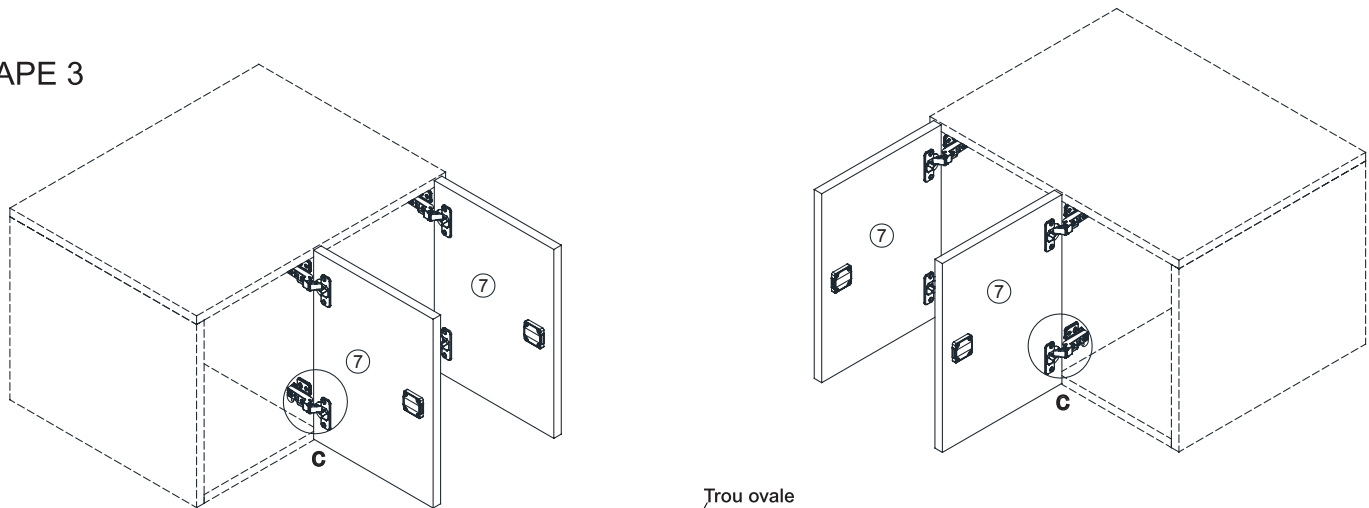

ÉTAPE 4

ATTENTION : Vis : n'utilisez que le trou ovale pour cette étape.

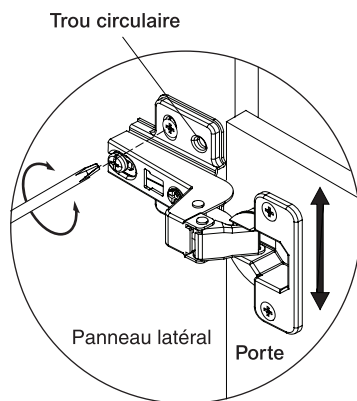

AJUSTEMENT DE LA HAUTEUR

Quand le réglage de la hauteur est correct, utilisez la vis « O » pour fixer la charnière dans le trou circulaire.

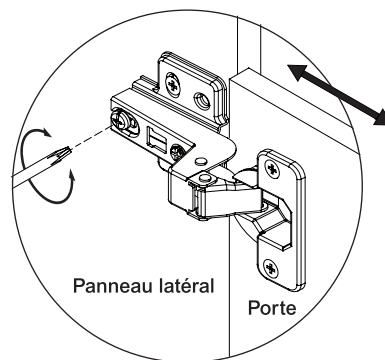

AJUSTEMENT DE LA PROFONDEUR

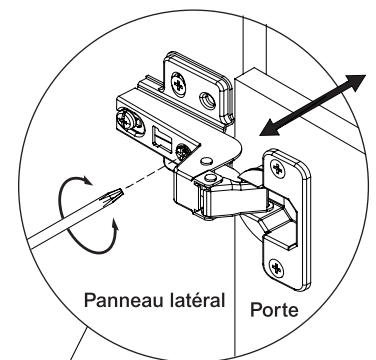

AJUSTEMENT DE L'ÉCART



Si la porte ne peut pas être fermée, serrez cette vis pour ajuster la porte.

NOTE IMPORTANTE :

- Déposez les pièces en mélamine et le plateau de verre sur une surface en tissu (nappe ou tapis) afin d'éviter de les égratigner.
- Vérifiez pour vous assurer que vous avez toutes les pièces et toute la quincaillerie.
- Enlevez tout le matériel d'emballage, incluant les agrafes et les courroies d'emballage avant de débuter l'assemblage.
- Ne serrez pas aucun des boulons/vis avant d'avoir assemblé toutes les pièces.
- Gardez toutes les pièces de quincaillerie hors de portée des enfants.
- Il est recommandé que 2 personnes effectuent cet assemblage.

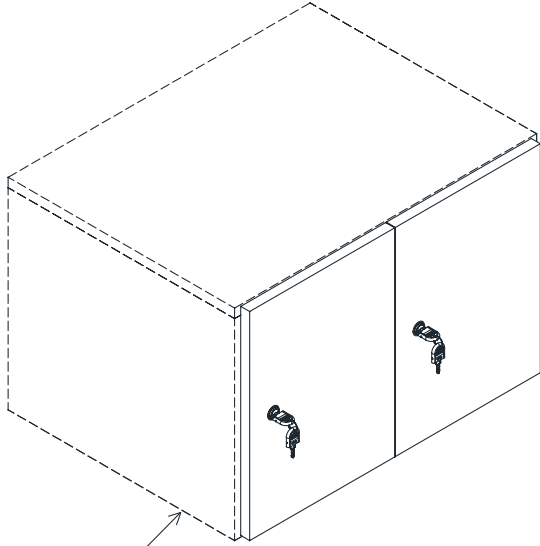

2 personnes sont requises pour l'assemblage et le déplacement de ce modèle.

MONTAGE FINALISÉ

Unité de casier double
LLR42403

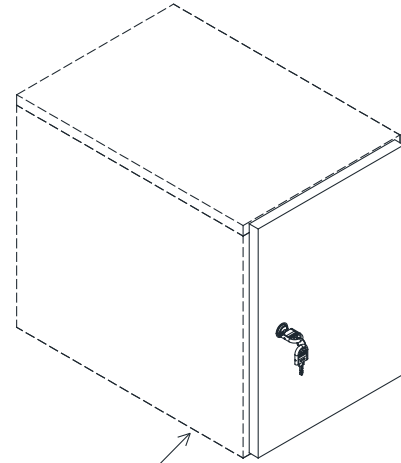





Unité de casier simple
LLR42402

NOTE IMPORTANTE :

- Déposez les pièces en mélamine et le plateau de verre sur une surface en tissu (nappe ou tapis) afin d'éviter de les égratigner.
- Vérifiez pour vous assurer que vous avez toutes les pièces et toute la quincaillerie.
- Enlevez tout le matériel d'emballage, incluant les agrafes et les courroies d'emballage avant de débuter l'assemblage.
- Ne serrez pas aucun des boulons/vis avant d'avoir assemblé toutes les pièces.
- Gardez toutes les pièces de quincaillerie hors de portée des enfants.
- Il est recommandé que 2 personnes effectuent cet assemblage.





2 personnes sont requises pour l'assemblage
et le déplacement de ce modèle.

K  Pestillo de bloqueo 1 juego	L  Cerradura 1 juego	M  Tornillo 3.5*20 4 unidades	N  Bisagra 2 unidades	O  Tornillo 4*16 12 + 2 unidades adicionales
--------------------------------------------------------------------------------------------------------------------------------	-----------------------------------------------------------------------------------------------------------------------	-----------------------------------------------------------------------------------------------------------------------------------	------------------------------------------------------------------------------------------------------------------------	--------------------------------------------------------------------------------------------------------------------------------------------------

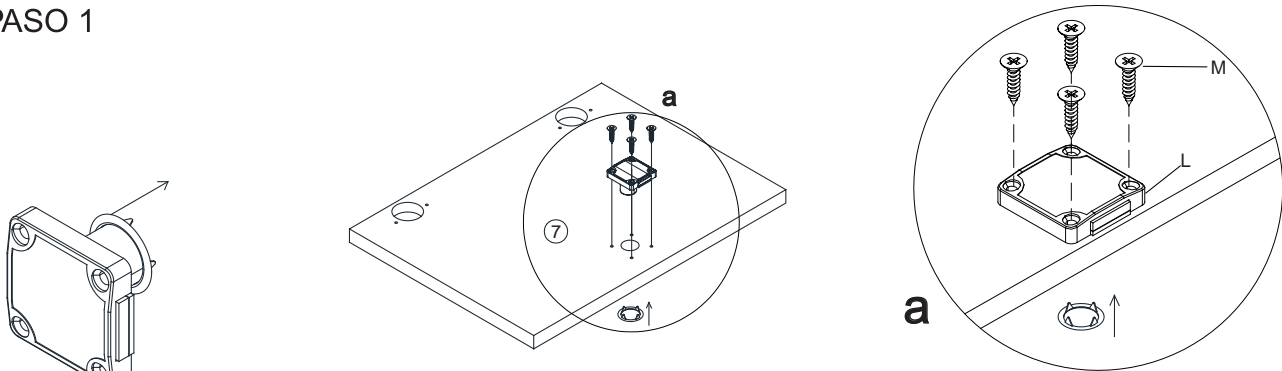
PASO 1



	L*1
	M*4

PASO 2

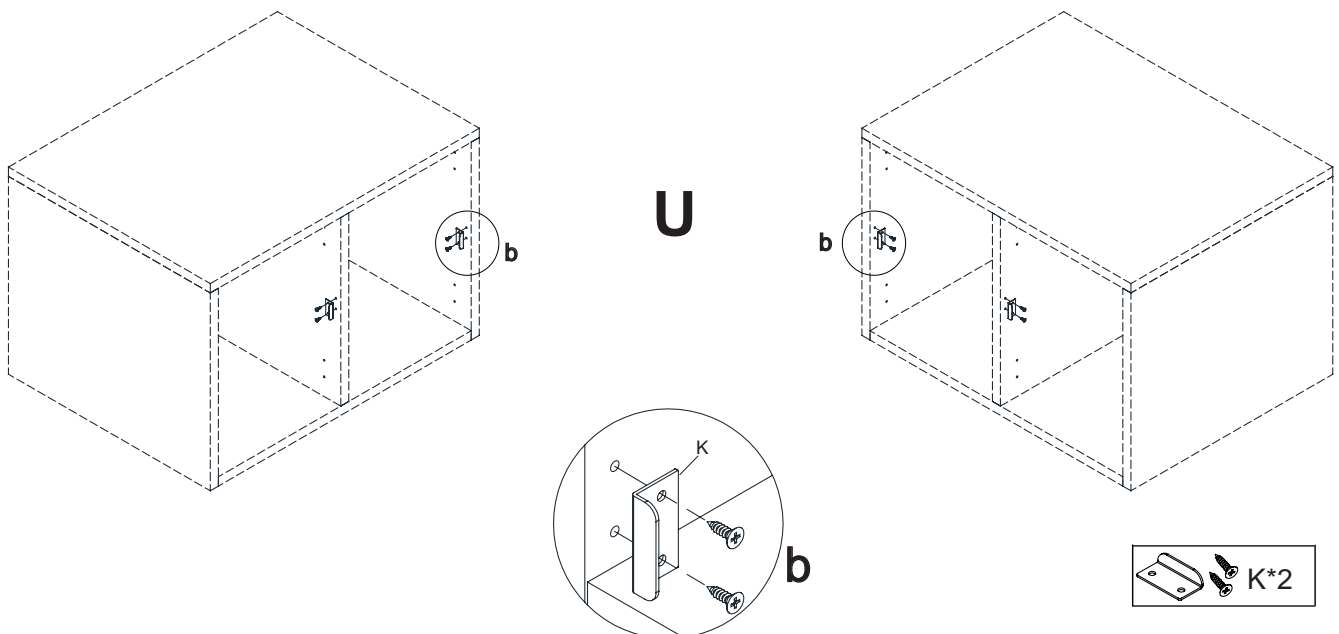

	K*2
---------------------------------------------------------------------------------------	-----

NOTA IMPORTANTE:

- Coloque todas las piezas laminadas y el tablero de vidrio en una superficie limpia y lisa como un tapete o una alfombra para evitar que las partes se rayen.
- Asegúrese de tener todas las partes y la ferretería.
- Antes de empezar a ensamblar remueva todos los materiales de empaque, incluyendo grapas y cintas.
- No apriete todos los tornillos o pernos hasta haber ensamblado todas las piezas.
- Mantenga toda la ferretería fuera del alcance de los niños.
- Se recomienda que dos personas realicen este ensamble.



PASO 3

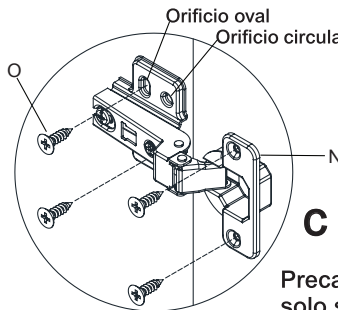
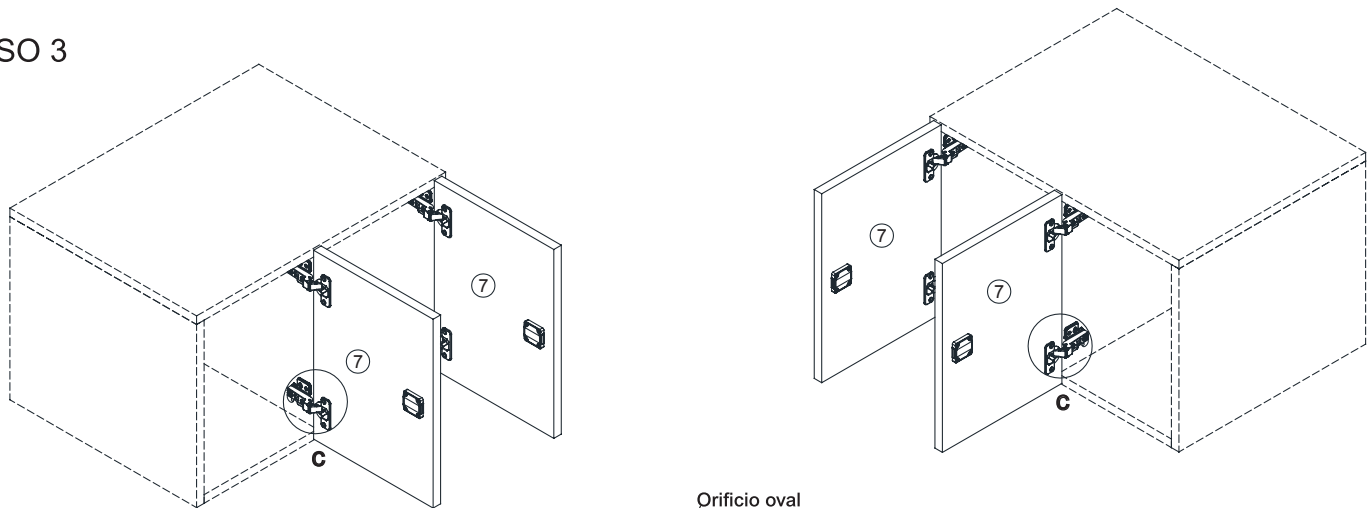

	N*4
	O*16

PASO 4

Precaución: En este paso solo se usa el orificio oval para los tornillos.

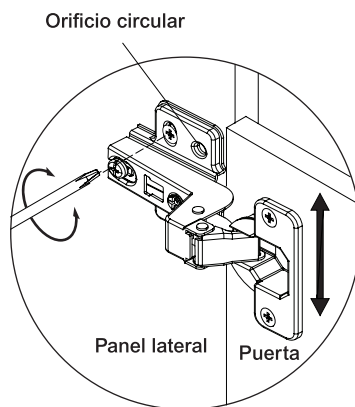

AJUSTE DE ALTURA

Una vez ajustada la altura, use el tornillo "o" para ajustar la bisagra en el orificio circular.

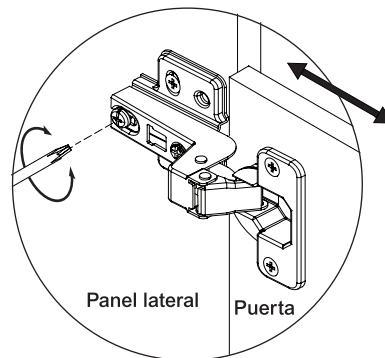

AJUSTE DE PROFUNDIDAD

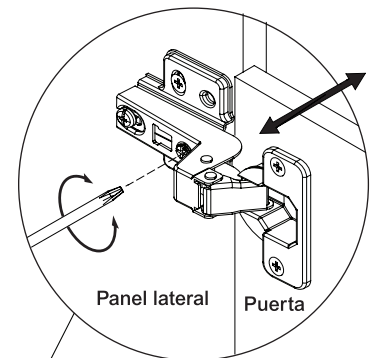

AJUSTE DE ESPACIO



Si la puerta no puede estar cerrada, aprieta este tornillo para ajustarla.

NOTA IMPORTANTE:

- Coloque todas las piezas laminadas y el tablero de vidrio en una superficie limpia y lisa como un tapete o una alfombra para evitar que las partes se rayen.
- Asegúrese de tener todas las partes y la ferretería.
- Antes de empezar a ensamblar remueva todos los materiales de empaque, incluyendo grapas y cintas.
- No apriete todos los tornillos o pernos hasta haber ensamblado todas las piezas.
- Mantenga toda la ferretería fuera del alcance de los niños.
- Se recomienda que dos personas realicen este ensamble.

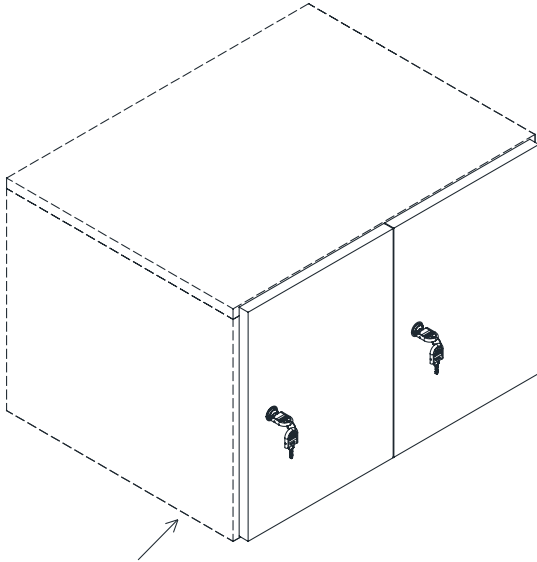

Se necesitan dos personas para ensamblar y mover este modelo.

ARMADO COMPLETO

Adicionador de armario doble abierto
LLR42403

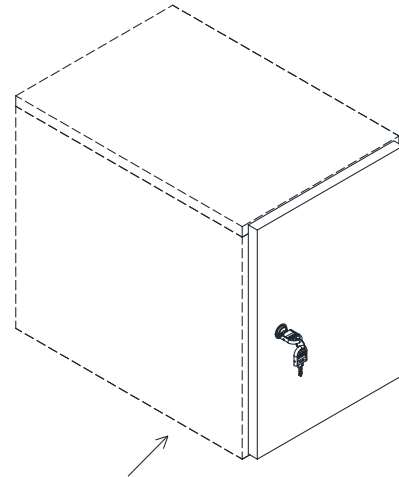

Adicionador de armario individual abierto
LLR42402

NOTA IMPORTANTE:

- Coloque todas las piezas laminadas y el tablero de vidrio en una superficie limpia y lisa como un tapete o una alfombra para evitar que las partes se rayen.
- Asegúrese de tener todas las partes y la ferretería.
- Antes de empezar a ensamblar remueva todos los materiales de empaque, incluyendo grapas y cintas.
- No apriete todos los tornillos o pernos hasta haber ensamblado todas las piezas.
- Mantenga toda la ferretería fuera del alcance de los niños.
- Se recomienda que dos personas realicen este ensamble.



Se necesitan dos personas para
ensamblar y mover este modelo.

Instructions

CALL US FIRST! DO NOT RETURN TO STORE.

For immediate help with assembly or product information call our toll-free number: **1-888-598-7316** Mon. - Fri. 7am to 7 pm CST
Our staff is ready to provide assistance. Damaged or missing parts ship from our facility in 1-2 business days.

Please provide the following information:

1. Full Name
2. Physical Address – do not include P.O. Box as our carriers cannot deliver to P.O. Boxes
3. Phone Number
4. Model Number
5. Part Number
6. Invoice #
7. Date of Purchase

Note: Our policy is to send all parts requests via normal ground transportation. If your requirements are to have these parts via overnight/next day, please provide your designated carrier and account number. Replacement panels are not available. If any damage has occurred during shipment please return the entire unit to place of purchase for credit and replacement. Original invoice may be required.

Before you begin:

Open, identify and count all parts prior to assembly. Lay out the parts on a non-abrasive surface such as carpet or blanket.

Instructions

APPELEZ-NOUS D'ABORD! NE REVENEZ PAS AU MAGASIN.

Pour obtenir une aide immédiate concernant l'assemblage ou des informations sur les produits, appelez notre numéro sans frais :
1-888-598-7316 Lun. - vend. 7h à 19 h CST Notre personnel vous attend pour vous offrir son aide.
Les pièces endommagées ou manquantes sont expédiées de nos locaux sous 1 à 2 jours ouvrables.

Veillez inclure les informations suivantes :

1. Nom complet
2. Adresse physique – ne pas inclure de boîte postale, car nos porteurs ne peuvent pas livrer à ces boîtes.
3. Numéro de téléphone
4. Numéro de modèle
5. Numéro de pièce
6. Numéro de facture
7. Date d'achat

Remarque : Notre politique est d'envoyer toutes les pièces demandées par transport terrestre normal. Si vous voulez recevoir ces pièces le jour suivant, indiquez votre porteur désigné ainsi qu'un numéro de compte. Nous ne fournissons pas de panneaux de rechange. En cas d'endommagement en cours de transport, renvoyez l'unité entière au lieu d'achat pour recevoir un crédit ou un échange. La facture originale vous sera peut-être demandée.

Avant de commencer:

Ouvrez, identifiez et comptez toutes les pièces avant l'assemblage. Disposez à plat les pièces sur une surface non abrasive comme un tapis ou une couverture.

Instrucciones

¡LLÁMENOS PRIMERO! NO DEVUELVA EL PRODUCTO A LA TIENDA.

Para recibir ayuda inmediata con el ensamble o información del producto, llame a nuestro número gratuito: **1-888-598-7316**
De lunes a viernes de 7 a.m. a 7 p.m., hora del Centro. Nuestro personal está preparado para brindarle asistencia.
Las partes dañadas o faltantes saldrán de nuestras instalaciones en el transcurso de 1 a 2 días hábiles.

Recuerde proporcionar la siguiente información:

1. Nombre completo
2. Domicilio físico – No incluya apartados postales debido a que no podemos realizar entregas en un apartado postal.
3. Número telefónico
4. Número de modelo
5. Número de parte
6. Número de factura
7. Fecha de compra

Nota: Nuestra política es enviar todas las solicitudes de partes por transporte terrestre regular. Si usted solicitó el envío de estas partes durante la noche o con entrega al día siguiente, proporcione el nombre de su compañía de mensajería y su número de cuenta. Los paneles de repuesto no están disponibles. Si ocurrió algún daño durante el envío, devuelva la unidad completa al lugar de compra para su devolución o reposición. Es posible que le pidan la factura original.

Antes de iniciar:

Abra, identifique y cuente todas las partes antes del ensamble. Coloque todas las partes en una superficie no abrasiva, como una alfombra o sábana.