















A  Cam Lock 13 PCS	B  Klix Cam 13 PCS	C  Dowel 2 PCS	D  Adjustable Glide 4 PCS	E  Aluminium Supports 50*14*40 5 PCS	F  Screw M6*50 5 PCS	G  60mm Black Grommet 1 PC	H  I-Bracket 2 PCS	I  Screw M6*20 12 PCS	J  Z Bracket 2 PCS	K  Screw #4*14 8 PCS	L  Cam Cover 16 PCS
--	---	---	---	---	---	--	--	--	---	---	--

STEP 1

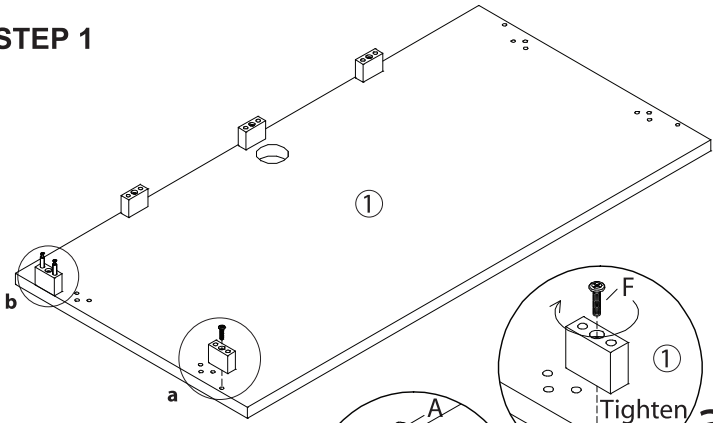

IMPORTANT:
FUNCTION OF KLIX CAM



1/4 RIGHT TURN FOR LOCKING

MAKE SURE THE ARROW IS POINTING UPWARDS BEFORE INSERTING INTO THE PANEL'S HOLE.

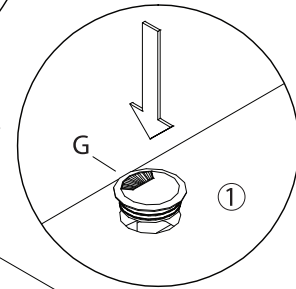
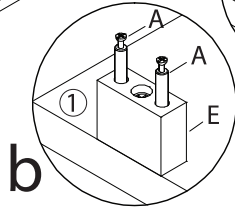

STEP 2

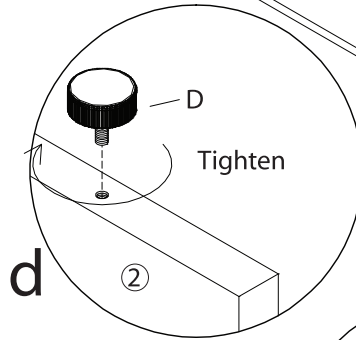
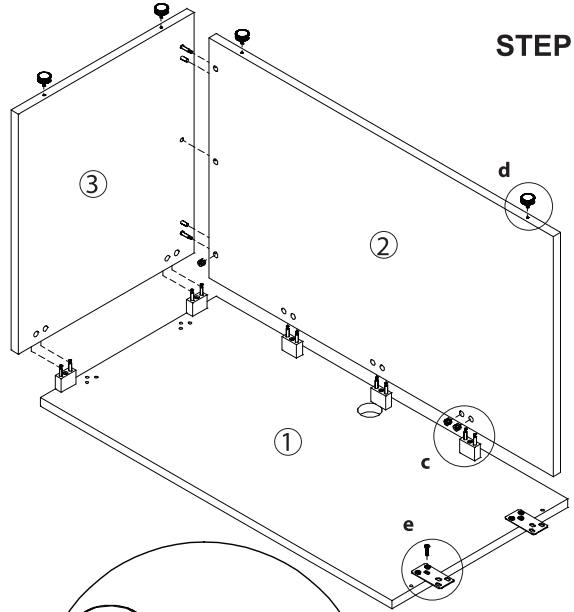

STEP 3

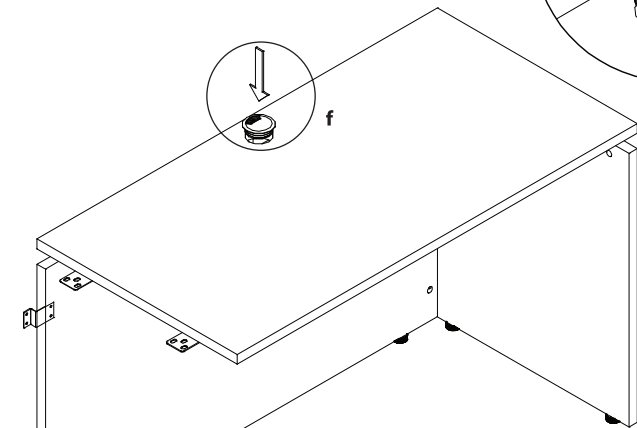

COMPLETED ASSEMBLY

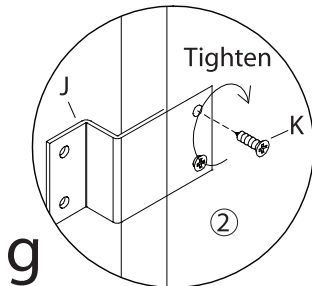



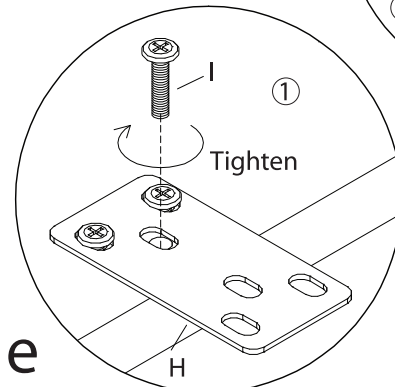
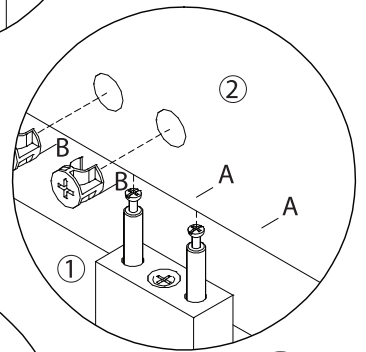









Install Aluminium support to desk top. Use Cam Cover L to cover the exposed Cam Klix B; other use Cover L to cover the Cam Klix B



IMPORTANT NOTE:

- Place all laminated parts on a clean and smooth surface such as a rug or carpet to avoid the parts from being scratched.
- Check to make sure that you have all parts and hardware.
- Remove all wrapping materials, including staples and packaging straps before your start to assemble.
- Do not tighten all screws/bolts until pieces are completely assembled.
- Keep all hardware parts out of children's reach.
- It is recommended 2 persons to complete the assembly.

A  Goujon 13 mcx	B  Excentrique 13 mcx	C  Tourillon 2 mcx	D  Vérin de réglage 4 mcx	E  Supports en Aluminium 50 x 14 x 40 5 mcx	F  Vis M6 x 50 5 mcx	G  Passe-câble noir 60mm 1 mc	H  Plaque de fixation 2 mcx	I  Vis M6*20 12 mcx	J  Glissière de rangement (Z) 2 mcx	K  Vis #4*14 8 mcx	L  Cache excentrique 16 mcx
--	--	---	--	---	---	--	---	--	--	---	--

ÉTAPE 1

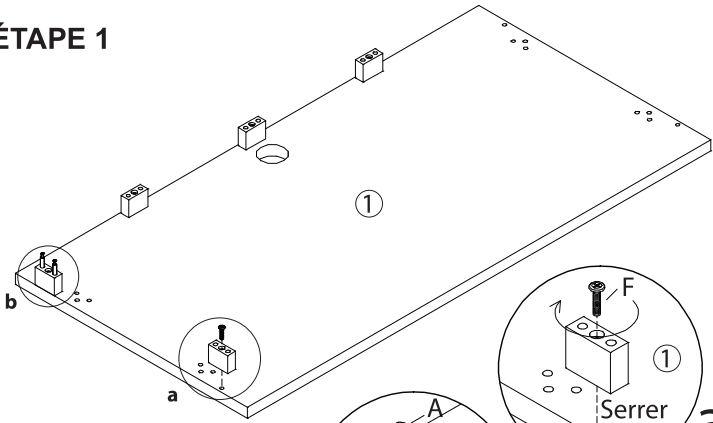

IMPORTANT:

FONCTION DE L'EXCENTRIQUE



S'ASSURER QUE LA FLECHE EST POSITIONNEE VERS LE HAUT AVANT DE L'INSERER DANS L'ORIFICE DU PANNEAU

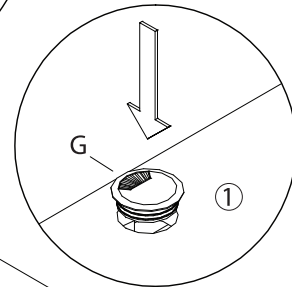
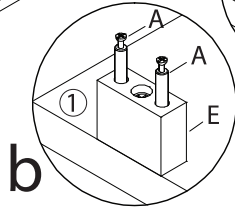

ÉTAPE 2

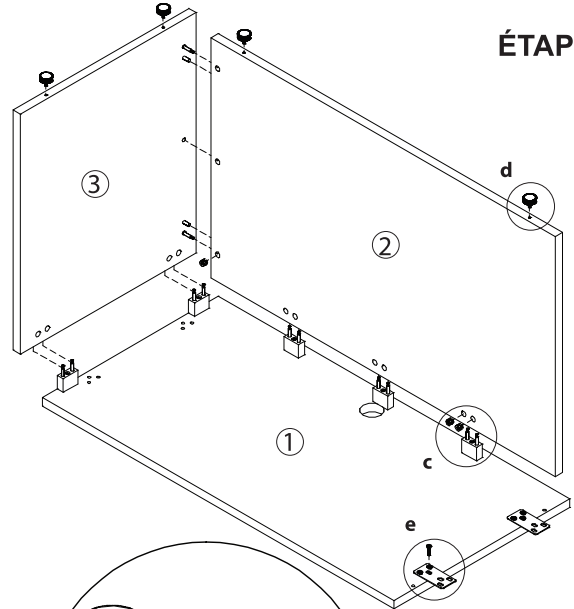

ÉTAPE 3

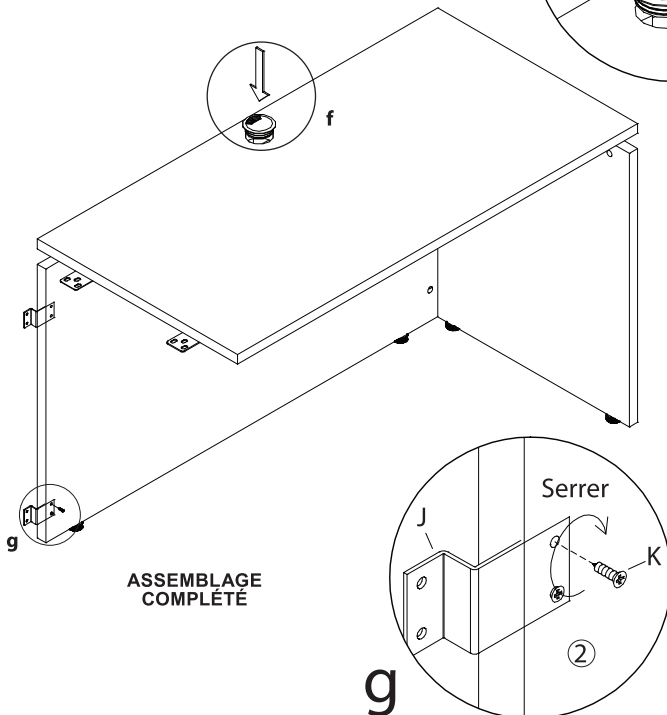





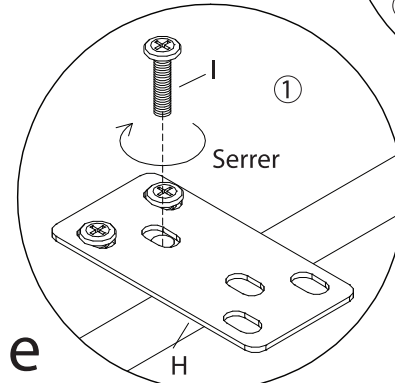
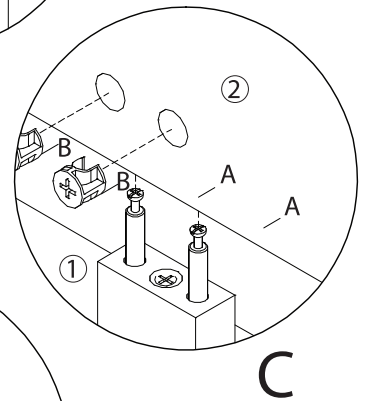







ASSEMBLAGE COMPLÈTE

Installer le support aluminium sur le haut du bureau. Utiliser le cache excentrique L pour couvrir l'excentrique exposé B; le cache excentrique L couvre l'excentrique B



NOTE IMPORTANT:

- Déposez toutes les pièces laminées sur une surface propre et douce comme sur une carpepe ou un tapis afin d'éviter l'éraflure des pièces.
- Vérifiez pour vous assurer que vous avez toutes les pièces et toute la quincaillerie.
- Enlevez tout le matériel d'emballage, incluant les agrafes et les courroies d'emballage avant de débiter l'assemblage.
- Ne serrez pas aucun des boulons/vis avant d'avoir assemblé toutes les pièces.
- Gardez toutes les pièces de quincaillerie hors de portée des enfants.
- Il est recommandé que le montage soit réalisé par 2 personnes.

A  Seguro de ajuste 13 pzas.	B  Leva 13 pzas.	C  Taquete 2 pzas.	D  Pata deslizable ajustable 4 pzas.	E  Soportes de aluminio 50 x 14 x 40 5 pzas.	F  Tornillo M6 x 50 5 pzas.	G  Arandela de cabo negra de 60 mm 1 pza	H  Soporte I 2 pzas.	I  Tornillo M6 x 20 12 pzas.	J  Soporte Z 2 pzas.	K  Tornillo #4 x14 8 pzas.	L  Cubierta de leva 16 pzas.
--	---	---	---	--	--	---	--	---	---	---	---

PASO 1

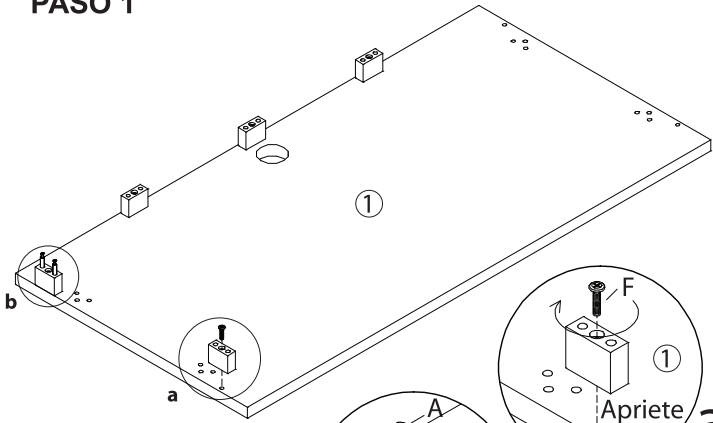

IMPORTANTE:
FUNCIONAMIENTO DE LAS LEVAS

 DÉ ¼ DE GIRO A LA DERECHA PARA ASEGURAR

VERIFIQUE QUE LA FLECHA APUNTE HACIA ARRIBA ANTES DE INSERTARLA EN EL ORIFICIO DEL TABLERO

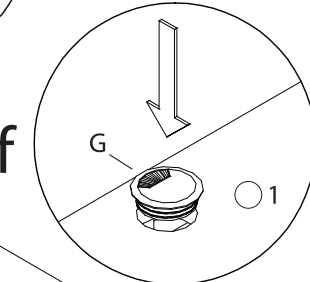
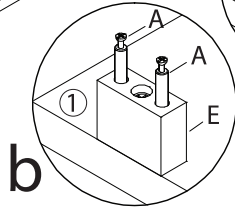

PASO 3

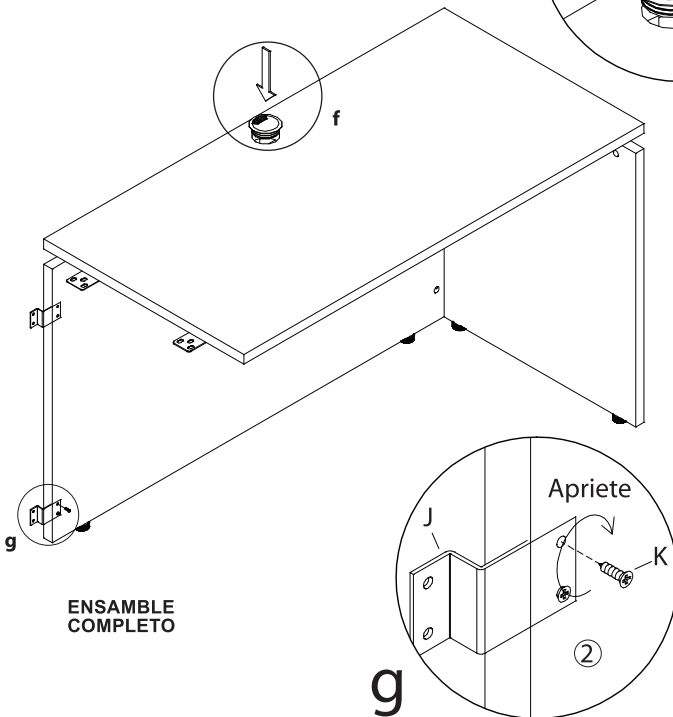

ENSAMBLE COMPLETO

PASO 2

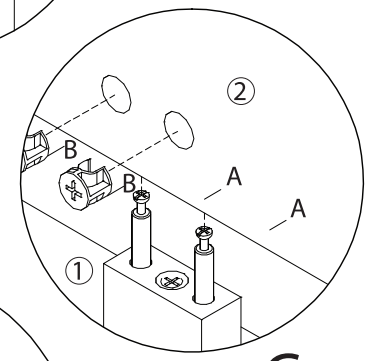
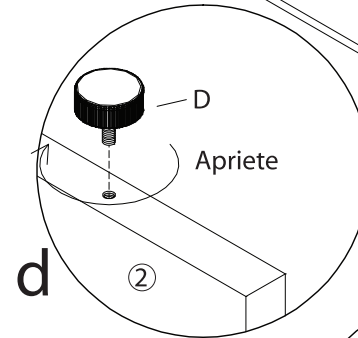
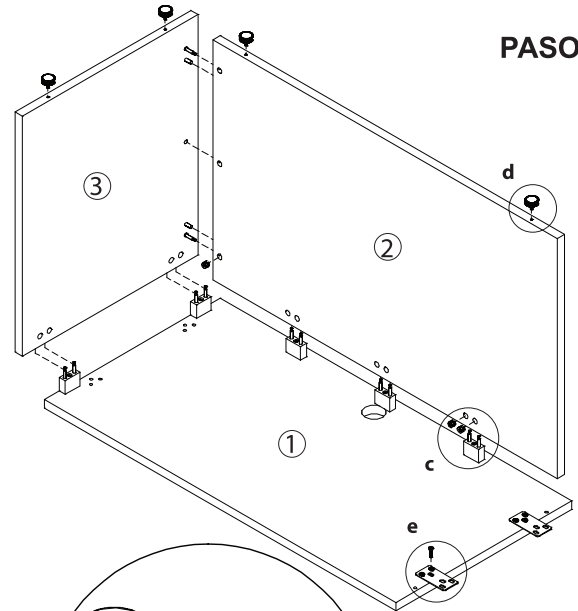

Instale el soporte de aluminio en la mesa del escritorio. Utilice la Cubierta de leva L para cubrir la Leva B expuesta; en la otra use la Cubierta L para cubrir la Leva B.

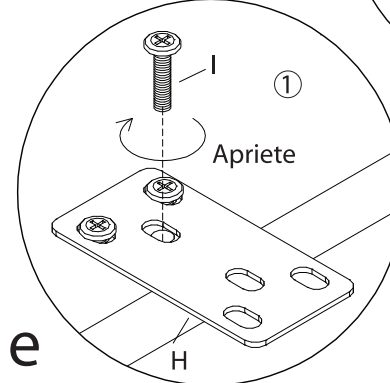

NOTA IMPORTANTE:

- Coloque todas las partes laminadas sobre una superficie limpia y uniforme (como un tapete o la alfombra) para evitar que se rayen.
- Asegúrese de tener todas las partes y la ferretería.
- Antes de empezar a ensamblar remueva todos los materiales de empaque, incluyendo grapas y cintas.
- No apriete todos los tornillos o pernos hasta haber ensamblado todas las piezas.
- Mantenga toda la ferretería fuera del alcance de los niños.
- Se recomienda que 2 personas realicen el ensamble.

Instructions

If you are missing parts or have other concerns, please email Lorell@sprich.com or fax: 404-472-9063. Please provide the following information:

1. Full Name
2. Physical Address – do not include P.O. Box as our carriers cannot deliver to a P.O. Boxes
3. Phone Number
4. Model Number
5. Part Number
6. Invoice #
7. Date of Purchase

Note: Our policy is to send all parts requests normal ground transportation, if your requirements are to have these parts via overnight/next day, please provide your designated carrier and account number. Replacement panels are not available. If damaged has occurred during shipment, please return the entire unit to place of purchase for credit and replacement. Original Invoice may be required.

Before you begin:

Open, identify and count all parts prior to assembly. Lay out the parts on a non-abrasive surface such as carpet or blanket.

Instructions

Veillez nous faire parvenir un courriel à lorell@sprich.com ou un fax à : 404-472-9063, s'il vous manque des pièces ou que vous éprouvez d'autres inquiétudes.

Veillez fournir l'information suivante :

1. Nom complet
2. Adresse physique – ne donnez pas votre boîte postale car nos livreurs ne peuvent pas livrer à une boîte postale
3. Numéro de téléphone
4. Numéro de modèle
5. Numéro de pièce
6. # de facture
7. Date de l'achat

Note: Notre politique est de livrer toutes les demandes de pièces par la voie terrestre; prière de fournir le nom de votre transporteur ainsi que votre numéro de compte si vos exigences sont d'avoir ces pièces livrées pendant la nuit/le lendemain. Des panneaux de remplacement ne sont pas disponibles. Si des dommages sont survenus durant le transport, prière de retourner l'unité entière à l'endroit de l'achat pour un crédit et un remplacement. La facture originale peut être exigée.

Avant de commencer:

Ouvrez, identifiez et comptez toutes les pièces avant de procéder à l'assemblage. Disposez les pièces sur une surface non-abrasive telle un tapis ou une couverture.

Instrucciones

Si le faltan partes o tiene alguna pregunta, escriba un mensaje de correo electrónico a Lorell@sprich.com o envíe un fax al 404-472-9063.

Recuerde incluir la siguiente información:

1. Nombre completo
2. Domicilio. No incluye apartado postal debido a que nuestros distribuidores no pueden hacer entregas a un apartado postal.
3. Número telefónico
4. Número de modelo
5. Número de parte
6. No. de factura
7. Fecha de compra

Nota: Nuestra política establece enviar todas las partes solicitadas vía terrestre. Si sus requisitos incluyen tener estas partes con un envío nocturno o al día siguiente, sírvase proporcionar su transportista asignado y número de cuenta.

No se cuenta con tableros de repuesto. Si la unidad sufrió algún daño durante el envío, regrésela completa a donde la adquirió para que le reembolsen su pago y se la reemplacen. Se le podría solicitar su factura original.

Antes de iniciar:

Abra, identifique y cuente todas las partes antes del ensamble. Coloque todas las partes en una superficie no abrasiva, como una alfombra o sábana.