









A  Adjustable Glide 4 PCS	B  128mm Aluminium Handle 2 Sets	C  File Clip 8 PCS + 2 PCS (Spare)	D  792*16*3mm Aluminium 2 PCS	E  378*16*3mm Aluminium 4 PCS	F  Keys 1 Set	G  Aluminium Supports 4 PCS	H  Screw M6*70 4 PCS	I  Screw M6*30 8 PCS
---	--	--	---	---	--	---	---	---

STEP 1



If you remove the Drawer please pull the drawer all the way out, then push the plastic tab of the ball bearing slide up on one side and down in the other side, and then pull the drawer completely out. See detail #A.

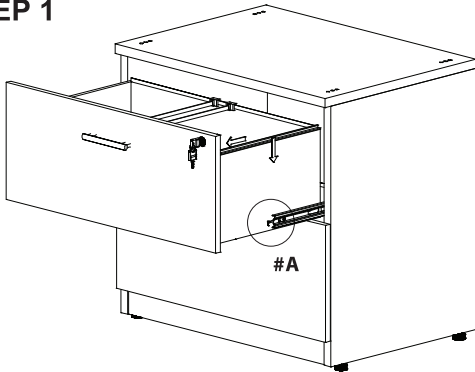
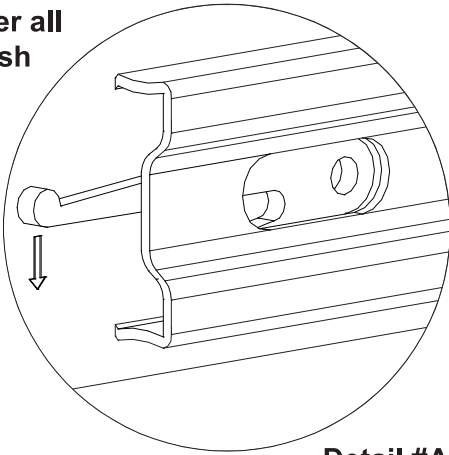

Detail #A

STEP 3

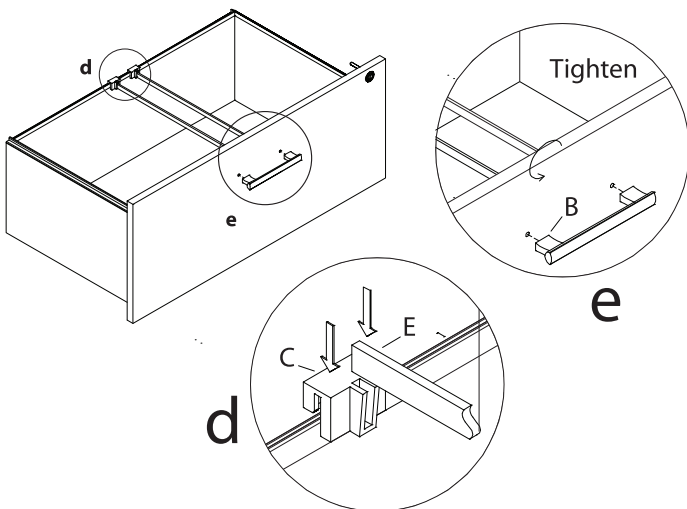



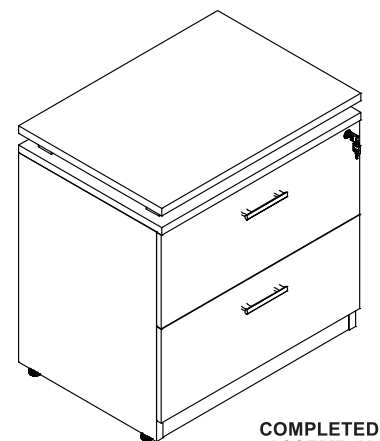
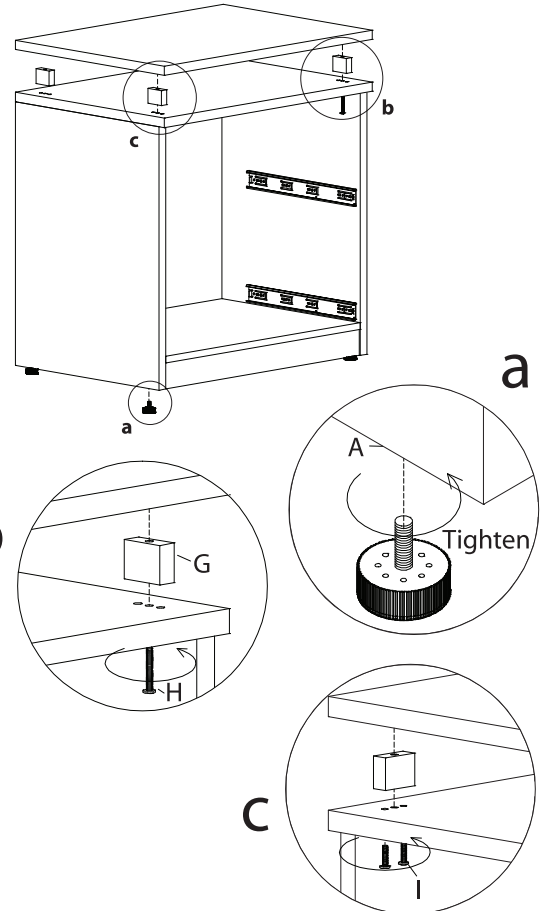





STEP 2



COMPLETED ASSEMBLY

IMPORTANT NOTE:

- Place all laminated parts on a clean and smooth surface such as a rug or carpet to avoid the parts from being scratched.
- Check to make sure that you have all parts and hardware.
- Remove all wrapping materials, including staples and packaging straps before your start to assemble.
- Do not tighten all screws/bolts until pieces are completely assembled.
- Keep all hardware parts out of children's reach.

A  Vérin de réglage 4 mcx	B  128mm Poignée en aluminium 2 Ensembles	C  Clip pour tasseau 8 mcx + 2 mcx (pièces de rechange)	D  792 x 16 x 3mm 2 mcx	E  378 x 16 x 3mm 4 mcx	F  Clés 1 Ensemble	G  Supports en Aluminium 4 mcx	H  Vis M6 x 70 4 mcx	I  Vis M6 x 30 8 mcx
---	---	---	--	--	---	---	---	---

ÉTAPE 1

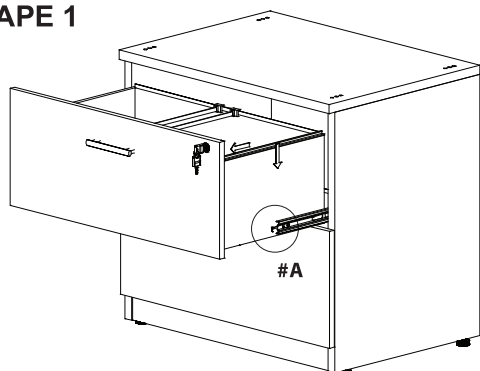

Si vous retirez le tiroir, veuillez le tirer au maximum, puis pousser la patte en plastique de la glissière à roulement à bille vers le haut d'un côté, et vers le bas de l'autre. Puis, retirer complètement le tiroir. Voir détail A

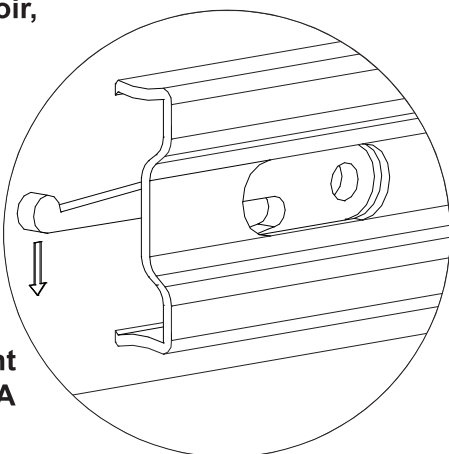

Détail #A

ÉTAPE 3

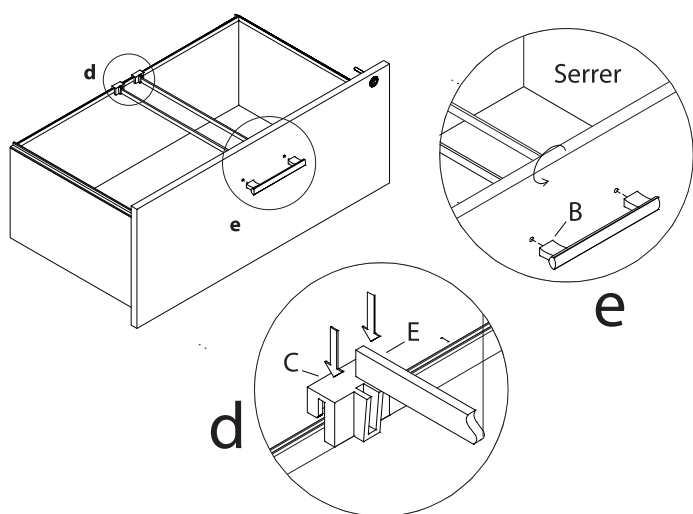



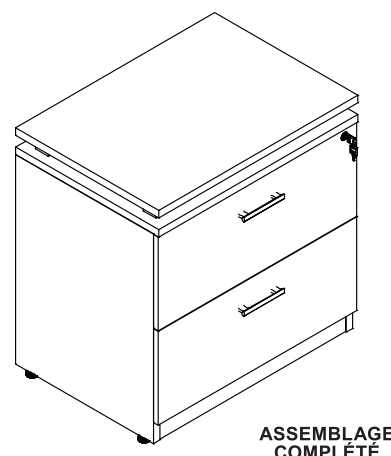
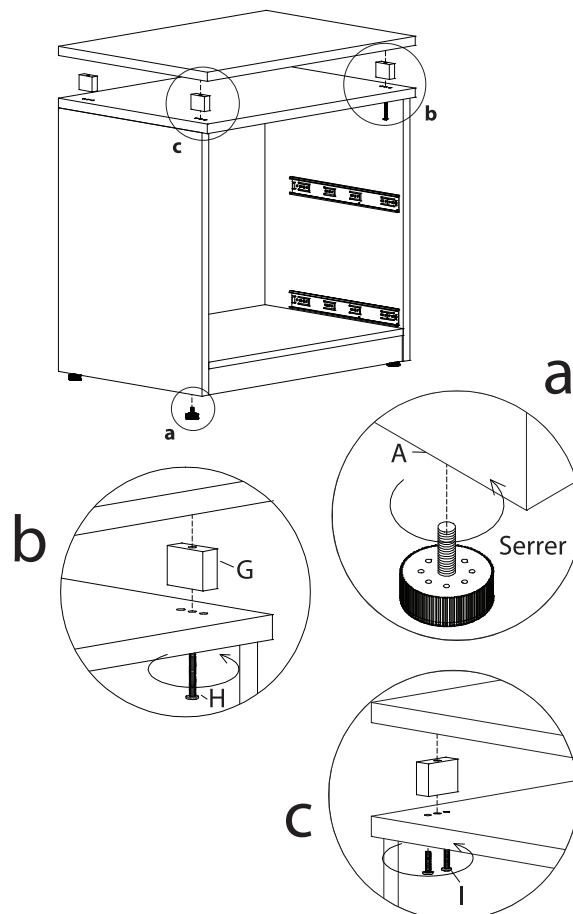





ÉTAPE 2



ASSEMBLAGE COMPLÉTÉ

NOTE IMPORTANT:

- Déposez toutes les pièces laminées sur une surface propre et douce comme sur une carapette ou un tapis afin d'éviter l'éraflure des pièces.
- Vérifiez pour vous assurer que vous avez toutes les pièces et toute la quincaillerie.
- Enlevez tout le matériel d'emballage, incluant les agrafes et les courroies d'emballage avant de débuter l'assemblage.
- Ne serrez pas aucun des boulons/vis avant d'avoir assemblé toutes les pièces.
- Gardez toutes les pièces de quincaillerie hors de portée des enfants.

<p>A</p>  <p>Pata deslizante ajustable 4 pzas.</p>	<p>B</p>  <p>128mm Manija de aluminio 2 Juegos</p>	<p>C</p>  <p>Clip para archivero 8 pzas. + 2 pzas. (repuestos)</p>	<p>D</p>  <p>792*16*3mm 2 pzas.</p>	<p>E</p>  <p>378*16*3mm 4 pzas.</p>	<p>F</p>  <p>Llaves 1 Juego</p>	<p>G</p>  <p>Soportes de aluminio 4 pzas.</p>	<p>H</p>  <p>Tornillo M6*70 4 pzas.</p>	<p>I</p>  <p>Tornillo M6*30 8 pzas.</p>
---	--	--	---	---	---	---	---	---

PASO 1

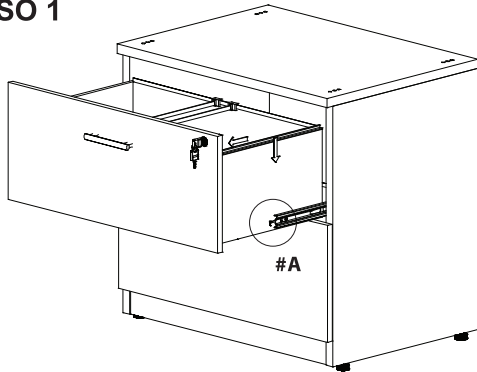

Para quitar el Cajón, jálelo todo hacia fuera. Luego, levante la lengüeta de plástico de la corredera con cojinetes de bolas de un lado y empuje hacia abajo la del otro lado, y saque por completo el cajón. Consulte el detalle "A".

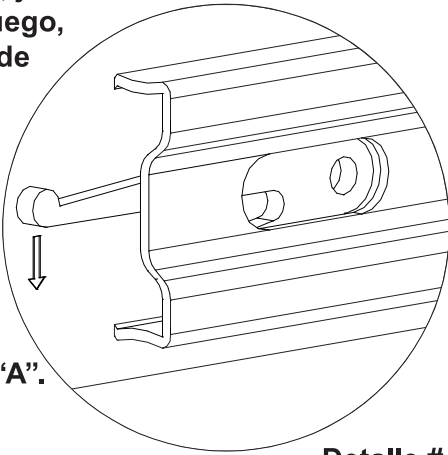

Detalle #A

PASO 3

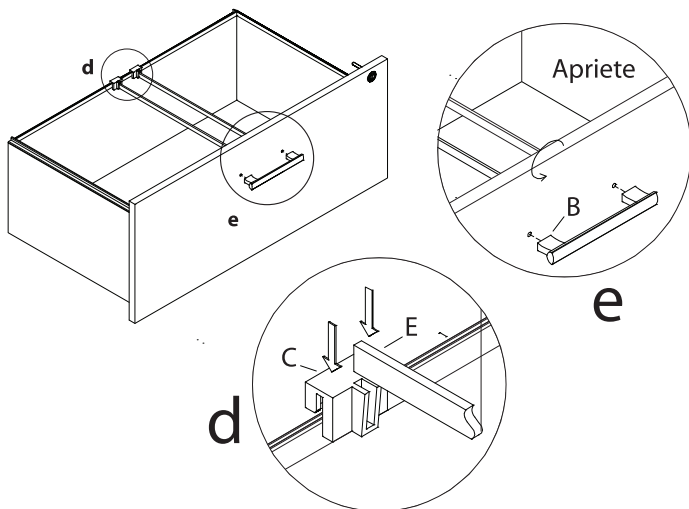

PASO 2

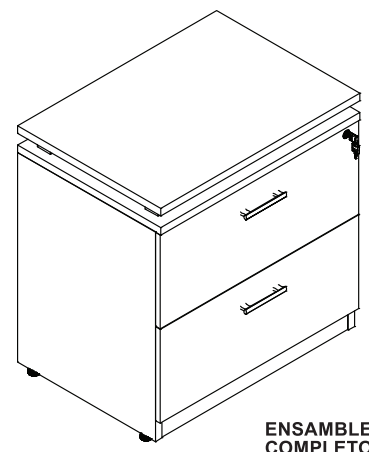
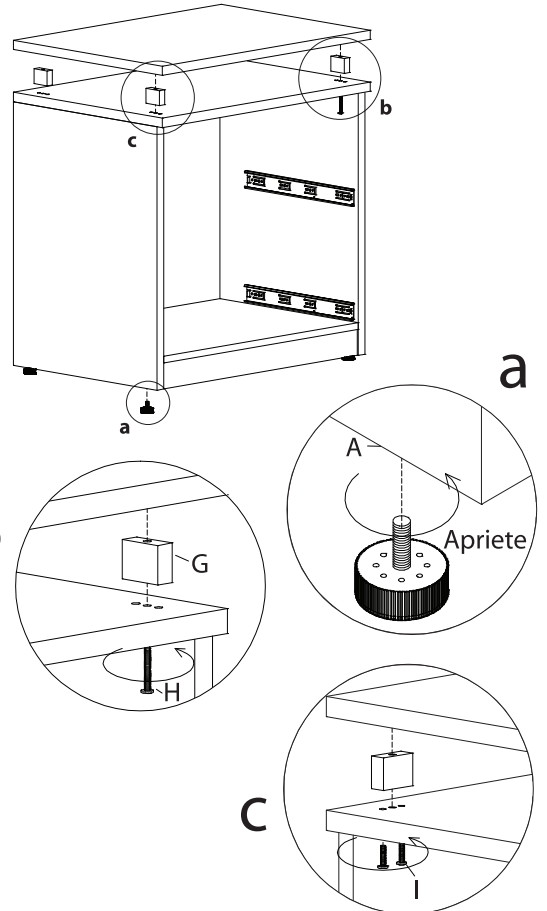

ENSAMBLE COMPLETO

NOTA IMPORTANTE:

- Coloque todas las partes laminadas sobre una superficie limpia y uniforme (como un tapete o la alfombra) para evitar que se rayen.
- Asegúrese de tener todas las partes y la ferretería.
- Antes de empezar a ensamblar remueva todos los materiales de empaque, incluyendo grapas y cintas.
- No apriete todos los tornillos o pernos hasta haber ensamblado todas las piezas.
- Mantenga toda la ferretería fuera del alcance de los niños.

Instructions

If you are missing parts or have other concerns, please email Lorell@sprich.com or fax: 404-472-9063. Please provide the following information:

1. Full Name
2. Physical Address – do not include P.O. Box as our carriers cannot deliver to a P.O. Boxes
3. Phone Number
4. Model Number
5. Part Number
6. Invoice #
7. Date of Purchase

Note: Our policy is to send all parts requests normal ground transportation, if your requirements are to have these parts via overnight/next day, please provide your designated carrier and account number. Replacement panels are not available. If damaged has occurred during shipment, please return the entire unit to place of purchase for credit and replacement. Original Invoice may be required.

Before you begin:

Open, identify and count all parts prior to assembly. Lay out the parts on a non-abrasive surface such as carpet or blanket.

Instructions

Veuillez nous faire parvenir un courriel à lorell@sprich.com ou un fax à : 404-472-9063, s'il vous manque des pièces ou que vous éprouvez d'autres inquiétudes.

Veuillez fournir l'information suivante :

1. Nom complet
2. Adresse physique – ne donnez pas votre boîte postale car nos livreurs ne peuvent pas livrer à une boîte postale
3. Numéro de téléphone
4. Numéro de modèle
5. Numéro de pièce
6. # de facture
7. Date de l'achat

Note: Notre politique est de livrer toutes les demandes de pièces par la voie terrestre; prière de fournir le nom de votre transporteur ainsi que votre numéro de compte si vos exigences sont d'avoir ces pièces livrées pendant la nuit/le lendemain. Des panneaux de remplacement ne sont pas disponibles. Si des dommages sont survenus durant le transport, prière de retourner l'unité entière à l'endroit de l'achat pour un crédit et un remplacement. La facture originale peut être exigée.

Avant de commencer:

Ouvrez, identifiez et comptez toutes les pièces avant de procéder à l'assemblage. Disposez les pièces sur une surface non-abrasive telle un tapis ou une couverture.

Instrucciones

Si le faltan partes o tiene alguna pregunta, escriba un mensaje de correo electrónico a Lorell@sprich.com o envíe un fax al 404-472-9063.

Recuerde incluir la siguiente información:

1. Nombre completo
2. Domicilio. No incluye apartado postal debido a que nuestros distribuidores no pueden hacer entregas a un apartado postal.
3. Número telefónico
4. Número de modelo
5. Número de parte
6. No. de factura
7. Fecha de compra

Nota: Nuestra política establece enviar todas las partes solicitadas vía terrestre. Si sus requisitos incluyen tener estas partes con un envío nocturno o al día siguiente, sírvase proporcionar su transportista asignado y número de cuenta.

No se cuenta con tableros de repuesto. Si la unidad sufrió algún daño durante el envío, regrésela completa a donde la adquirió para que le reembolsen su pago y se la reemplacen. Se le podría solicitar su factura original.

Antes de iniciar:

Abra, identifique y cuente todas las partes antes del ensamble. Coloque todas las partes en una superficie no abrasiva, como una alfombra o sábana.