

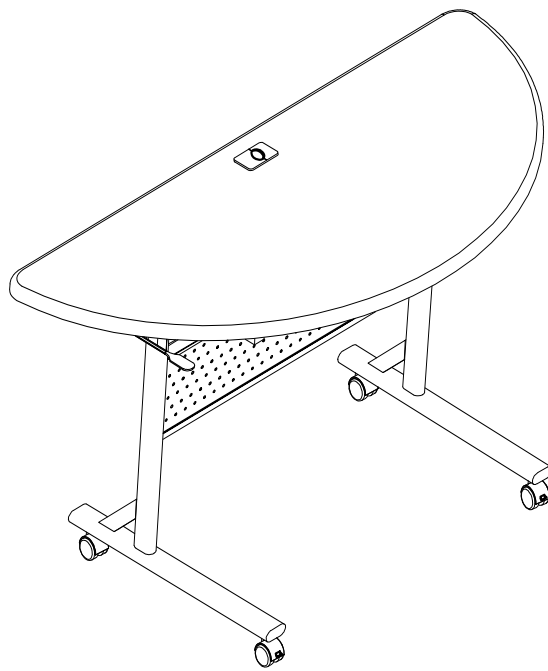

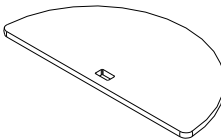

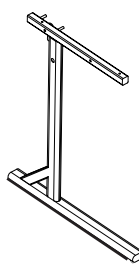





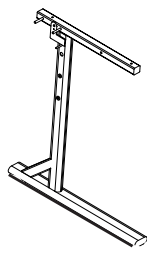
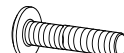
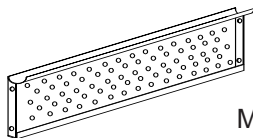
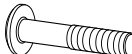
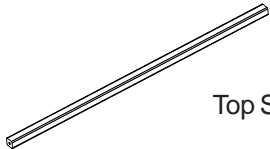
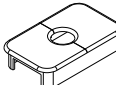
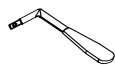

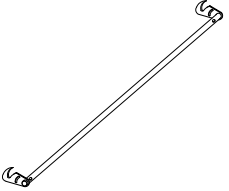
Flipper Table Half Round



Assembly Instructions

Flipper Table - Half Round

Part	Drawing	Description	Qty	Part	Drawing	Description	Qty
P1		Table Top	1 EA	Hardware List			
P2		Left Leg	1 EA	A		1/4"X12mm Socket Screw	8 EA
P3		Right Leg	1 EA	B		1/4"X45mm Socket Screw	5 EA
P4		Modesty Panel	1 EA	B1		1/4"X57mm Socket Screw	2 EA
P5		Top Support	1 EA	C		Plastic Grommet	1 EA
P6		Handle	2 EA	D		2" Locking Caster	2 EA
P7		Lock Rod	1 EA	D1		2" Caster	2 EA
				E		Allen Wrench	1 EA
				F		Caster Wrench	1 EA
				G		Lock Washer-Caster	4 EA
				H		Wood Screws	4 EA
				I		Connecting Bracket	2 EA
				J		Spring-Lock Rod	2 EA
				<i>We recommend that you assemble this unit on a table.</i>			

Do not use unless all screws are tight. At least every six months, check all screws to be sure they are tight. If parts are missing, broken, damaged, or worn, stop use of the product until repairs are made by your dealer using factory authorized parts.

Assembly Diagram

READ THROUGH INSTRUCTIONS FROM BEGINNING TO END BEFORE STARTING TO ASSEMBLE UNIT.

- 1.) Identify and Separate all the Parts and Hardware.
- 2.) Place the Table Top (P1) face down on a padded surface. Place the Left Leg (P2) over the embedded threaded inserts in the bottom of the Table Top. Attach the Left Leg to the Table Top using two Socket Screws (B) as shown in Illustration #1.

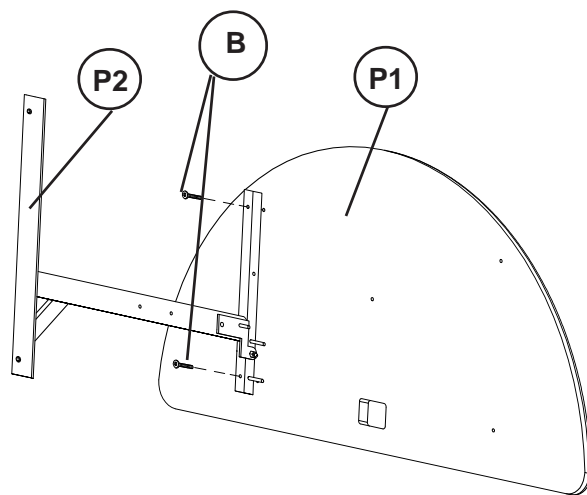

Illustration # 1

- 3.) Attach the Top Support (P5) to the Left Leg (P2) using one Socket Screw (B1). Use one Socket Screw (B) to attach the Top Support (P5) to the center hole in the Table Top (P1) as shown in Illustration #2.

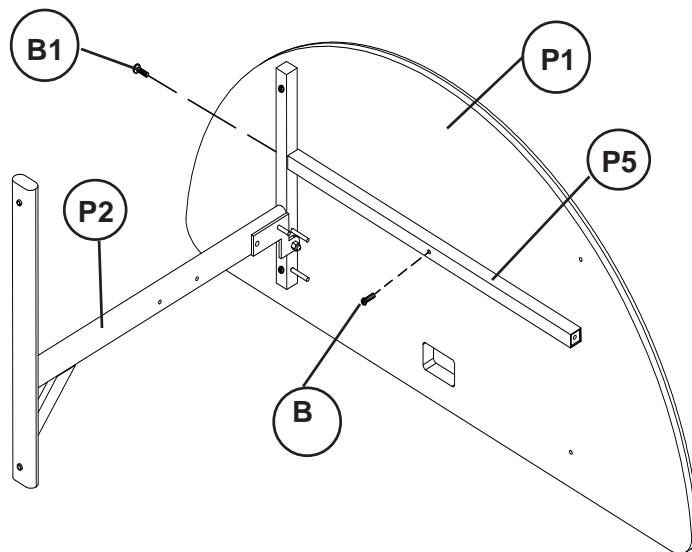

Illustration # 2

- 4.) Place the Lock Rod (P7), as shown in Illustration #3, against the Left Leg (P2) and align holes. Insert the Handle (P6) through the outside hole in the Left Leg (P2) and into the hole the the Lock Rod (P7). Align the screw holes and secure with one Socket Screw (A).

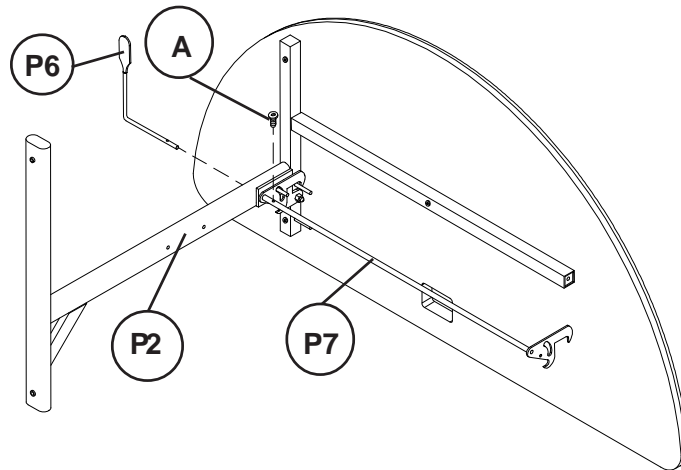

Illustration #3

- 5.) Place the Right Leg (P3) over the embedded threaded holes in the bottom of Table Top (P1). Make sure the pin on the inside of the Right Leg fits into the slot of the Lock Rod (P7) as it does on the Left Leg(P2). Secure the Right Leg (P3) to the Table Top (P1) using two Socket Screws (B). Attach the Top Support (P5) to the Right Leg using one Socket Screw (B1) as shown in Illustration #4. Insert the Handle (P6) through the Right Leg (P3) and into the Lock Rod and secure with a Socket Screw (A).

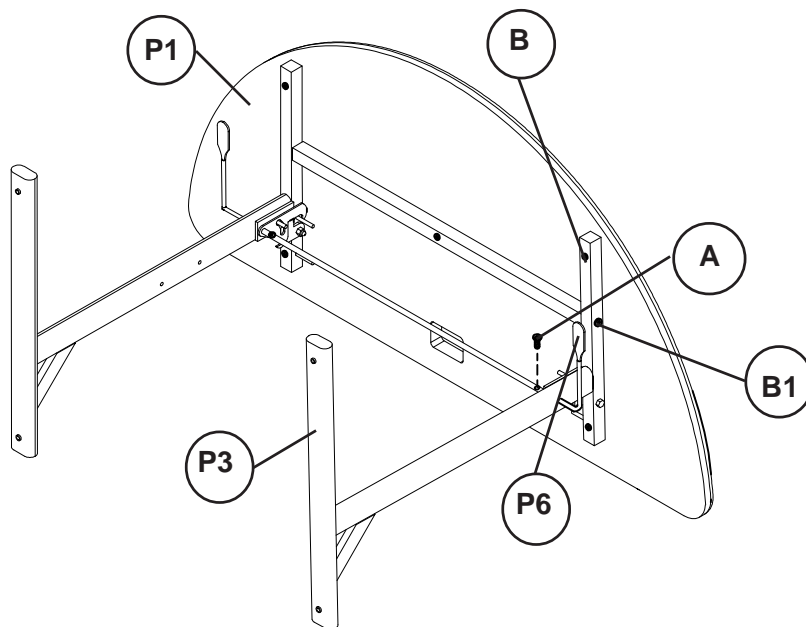
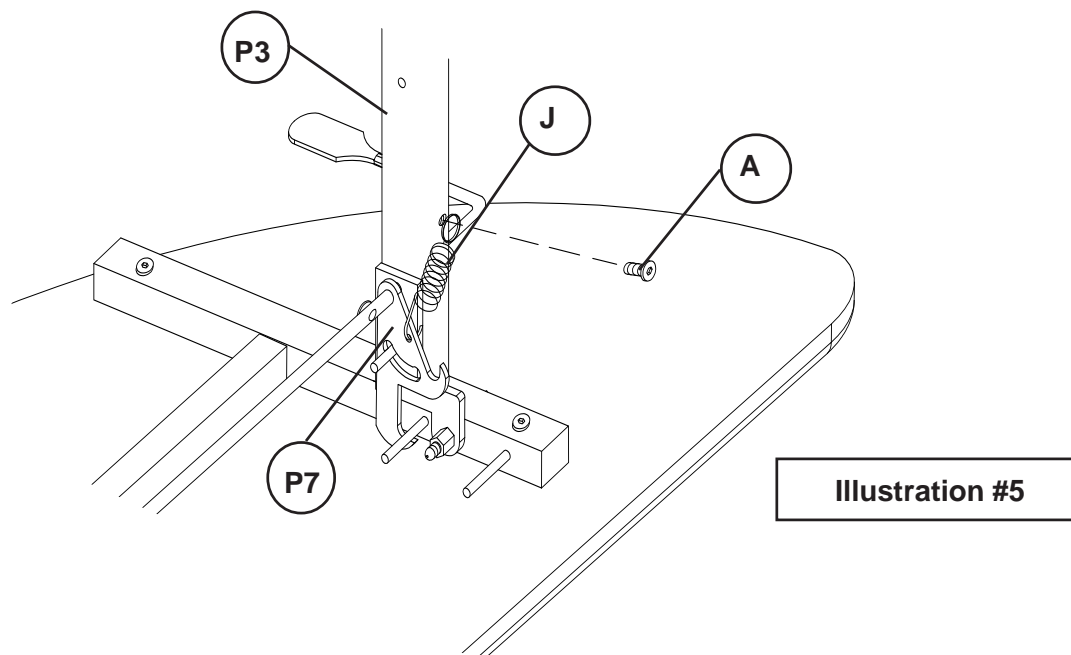
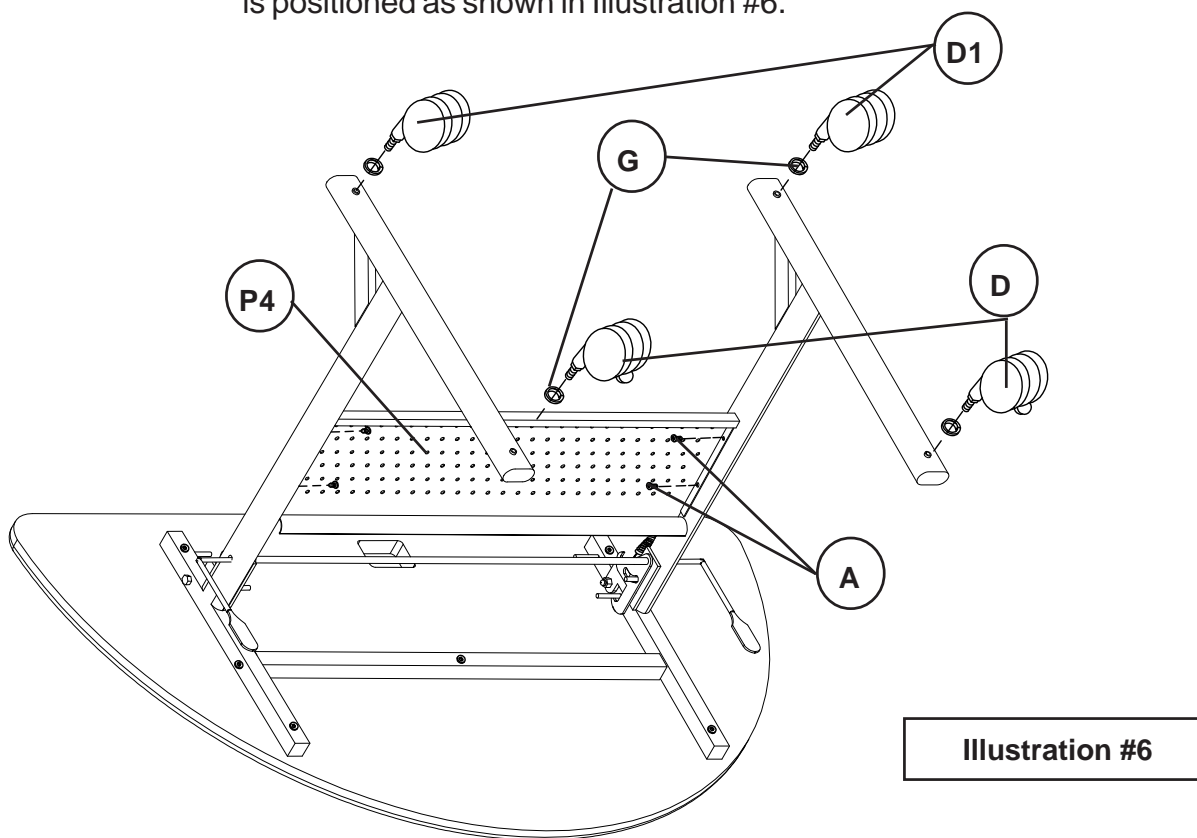

Illustration #4

- 6.) Attach the Spring (J) to the Right Leg (P3) using one Socket Screw (A) as shown in Illustration #5. Hook the other end of the Spring into the Lock Rod (P7) as shown. Repeat this Step for the Spring (J) to the Left Leg (P2) and Lock Rod (P7).



- 7.) Attach the Modesty Panel (P4) between the Right Leg (P3) and the Left Leg (P2) using two Socket Screws (A) into the threaded holes in each leg. Make sure your Modesty Panel (P4) is positioned as shown in Illustration #6.



- 8.) Place a Lock Washer (G) on each Caster (D1) and screw into the back holes in the bottom of the Right and Left Legs. Place a Lock Washer (G) on each Caster (D) and screw into the front holes in the bottom of the Right and Left Legs as shown in Illustration #6. Tighten all Casters with Caster Wrench (F).

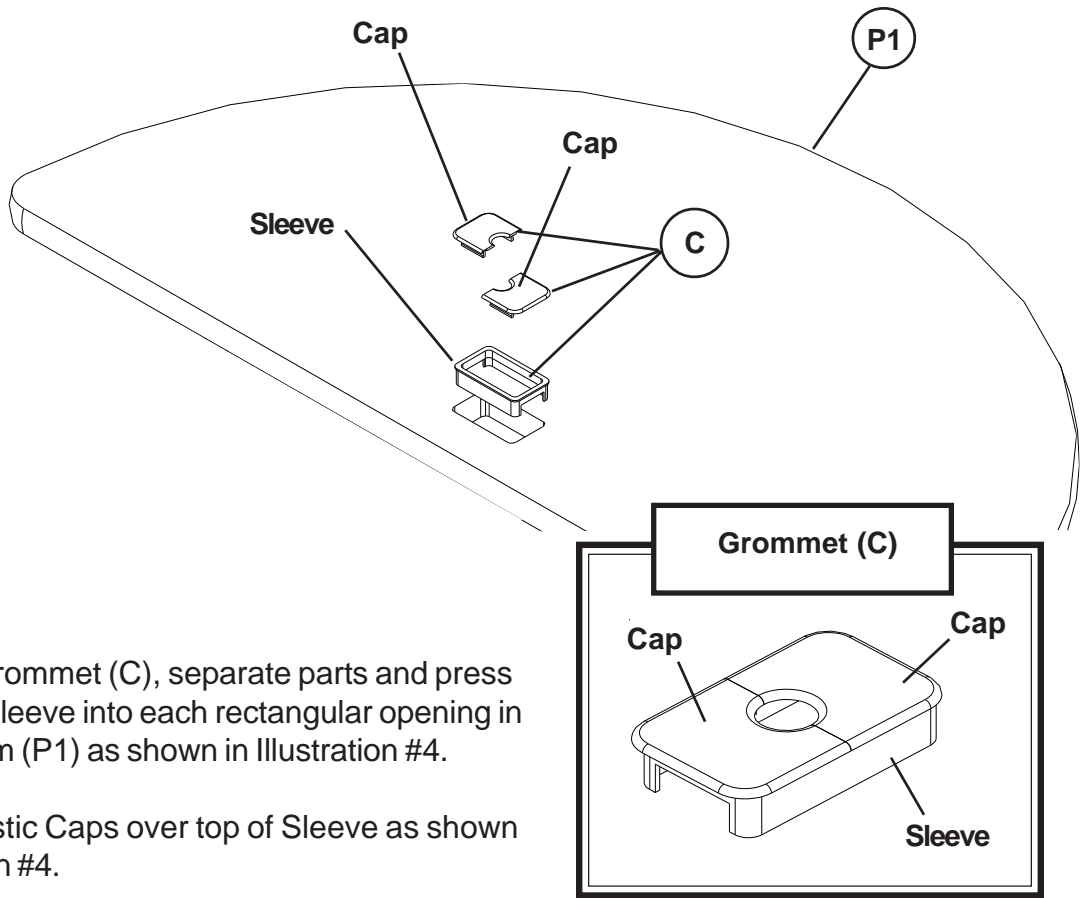

- 9.) To install Grommet (C), separate parts and press Grommet Sleeve into each rectangular opening in Top Platform (P1) as shown in Illustration #4.
- 10.) Snap 2 plastic Caps over top of Sleeve as shown in Illustration #4.

Illustration #7

- 11.) Use two Connecting Brackets(I) and four Wood Screws(H) to secure two tables together as shown in Illustration #5.

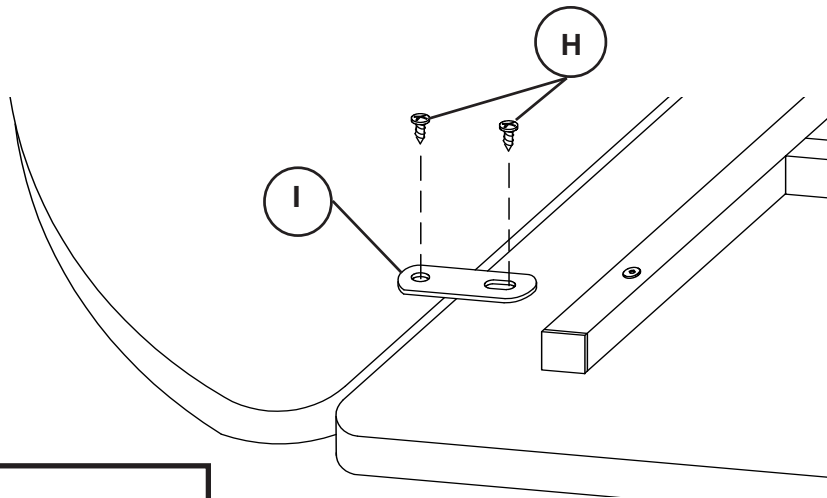

Illustration #8