

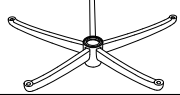





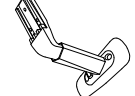
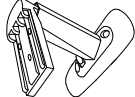

MESH HB WORK CHAIR

Item#: MH01

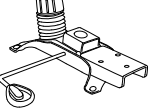
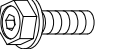
Part List			
Key	Description	Qty	Part
A	CASTERS	5	
B	BASE	1	
C	SEAT CUSHION	1	
D	RIGHT ARMREST	1	
E	LEFT ARMREST	1	
F	ARMREST SCREWS D 1/4" x L 1-3/8"	6	
G	FLAT WASHERS	6	
H	MECHANISM	1	
I	MECHANISM SCREWS D 5/16" x L 7/8"	4	
J	BACK SUPPORT	1	
K	BACK SUPPORT SCREWS D 5/16" x L 5/8"	3	
L	ALLEN WRENCH	1	
M	GAS LIFT	1	

ATTENTION: Make certain that all screws are fully tightened before using chair.
Lubricate all moving parts and tighten all screws every 6 months or as needed.

Step 1

Turn Base "B" upside down. Insert Casters "A" into Base "B".

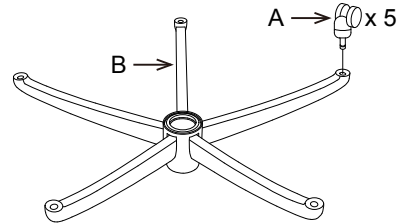

Step 2

Attach Right Armrest "D" to Seat Cushion "C" with Armrest Screws "F" and Flat Washers "G". Repeat for Left Armrest "E". NOTE: Arrows on armrests point to front of seat cushion and fully tighten all screws.

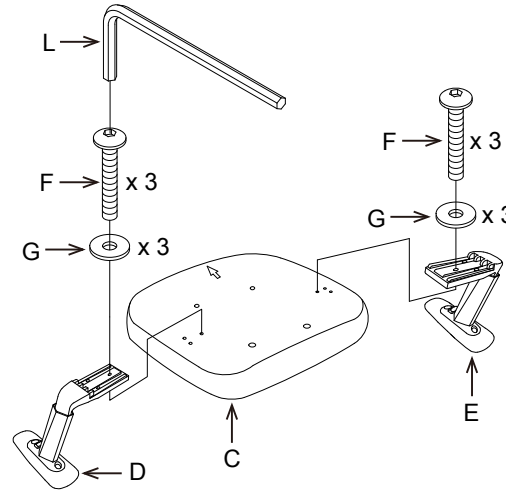

Step 3

Attach Mechanism "H" to Seat Cushion "C" with Mechanism Screws "I". NOTE: Fully tighten all screws.

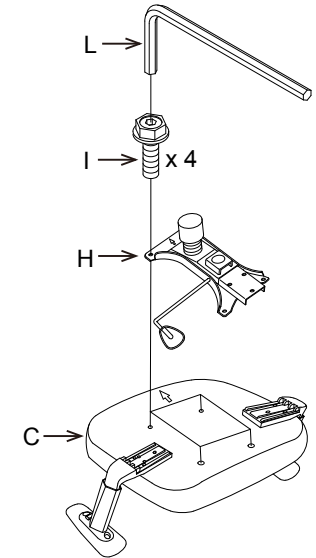

Step 4

Attach Back Support "J" to the rear of Mechanism "H" with Back Support Screws "K". NOTE: Fully tighten all screws.

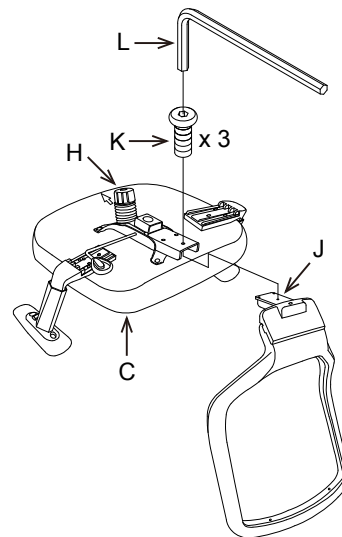

Step 5

Insert Gas Lift "M" into hole on Base "B".

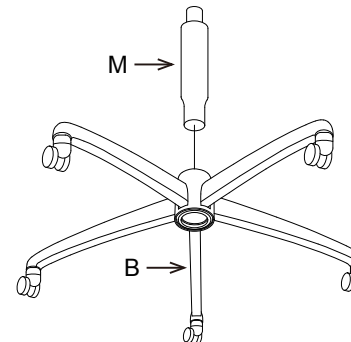

Step 6

Place seat assembly onto Gas Lift "M". Push firmly on the chair seat to securely attach seat assembly to seat post.

