

6) Drawers

Slide drawers into the side channels underneath each shelf.

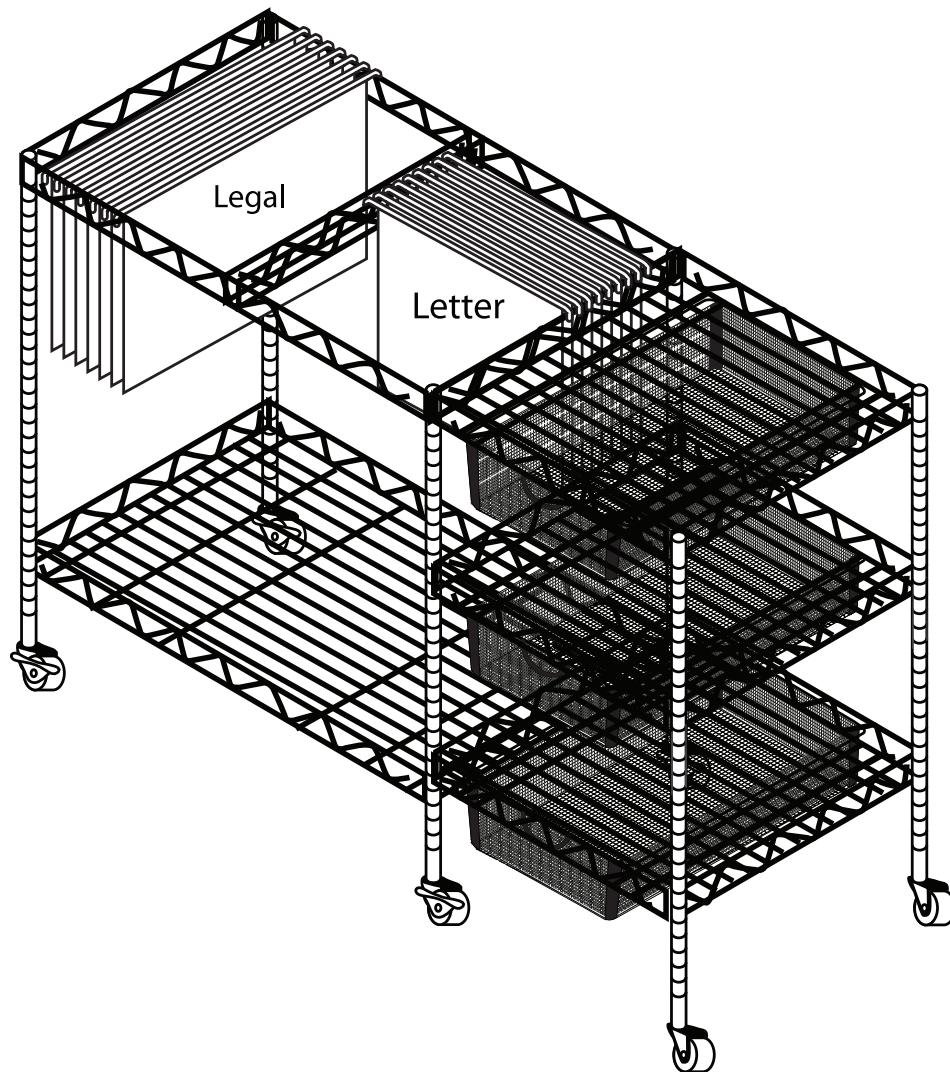
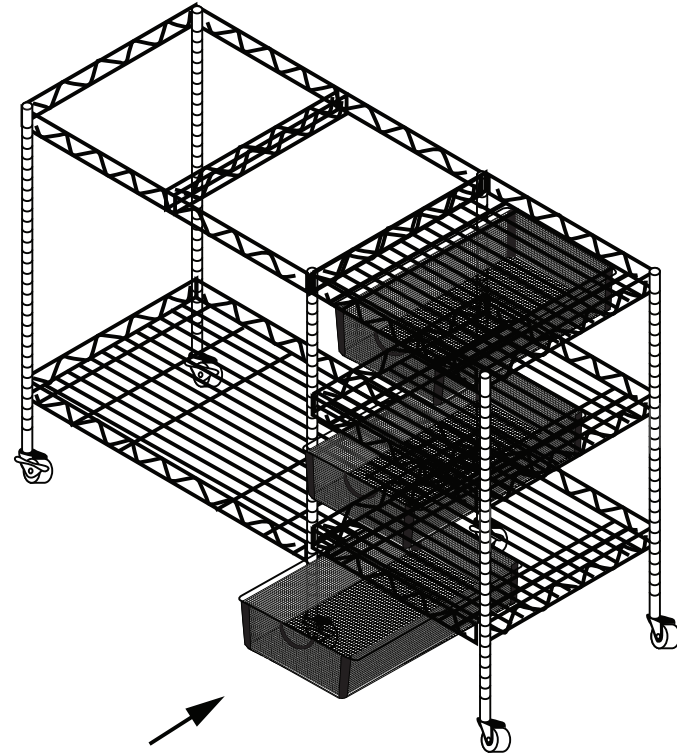

The unit can accommodate letter and legal size folders.

Mobile File Cart with 3 Drawers VF50621

Vertiflex
Products™

Assembly Instructions

www.advantus.com

904.482.0091

Before You Begin

Review all instructions before beginning assembly.

Before starting, check the parts you've received against the parts list. Separate, identify and count all hardware parts. If you are missing any pieces, please contact Advantus customer service.

This unit can be cleaned with a mild detergent and a damp cloth.

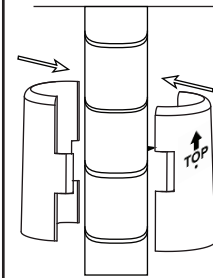

Compression Clip Assembly

1. Begin with TOP pointing up.
2. Place around leg using indents to align at desired position. Remember you need room for other shelves. Adjust accordingly.
3. Use care to ensure clips do not move during shelf installation.

1) Install Casters on Legs (6x)

Screw the threaded caster shank into the threaded hole in the bottom of the leg. Tighten using the wrench (included). Repeat for each of the six (6) legs. Do not overtighten.

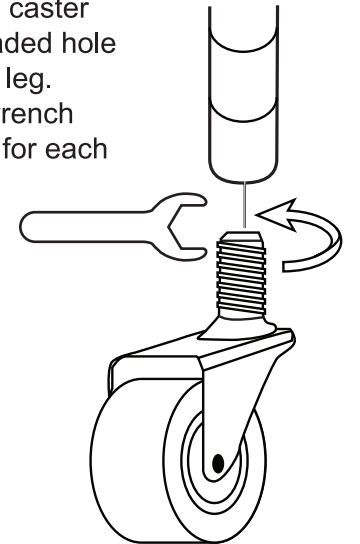

Parts List



6 Legs



6 Casters

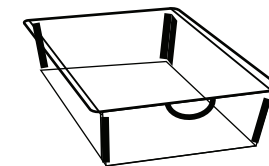

3 Drawers

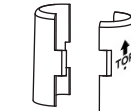

36 Compression Clips



Wrench

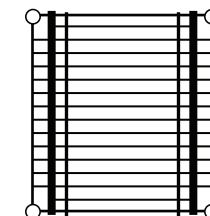

2 Small Shelves

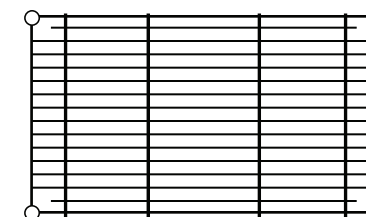

1 Large Bottom Shelf

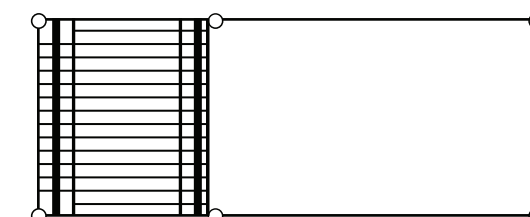

1 Large Top Shelf

2) Attach Compression Clips to Legs

With both halves of the compression clip facing **TOP** snap the halves together around the second groove above the caster (as shown). Repeat for each of four (4) legs.

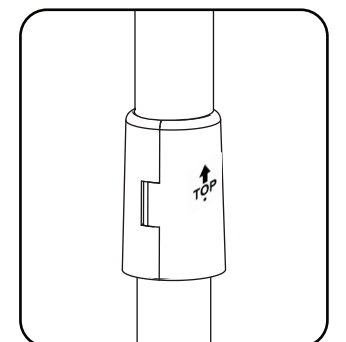
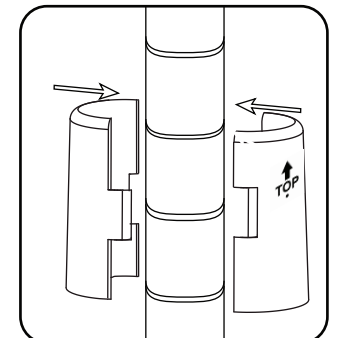

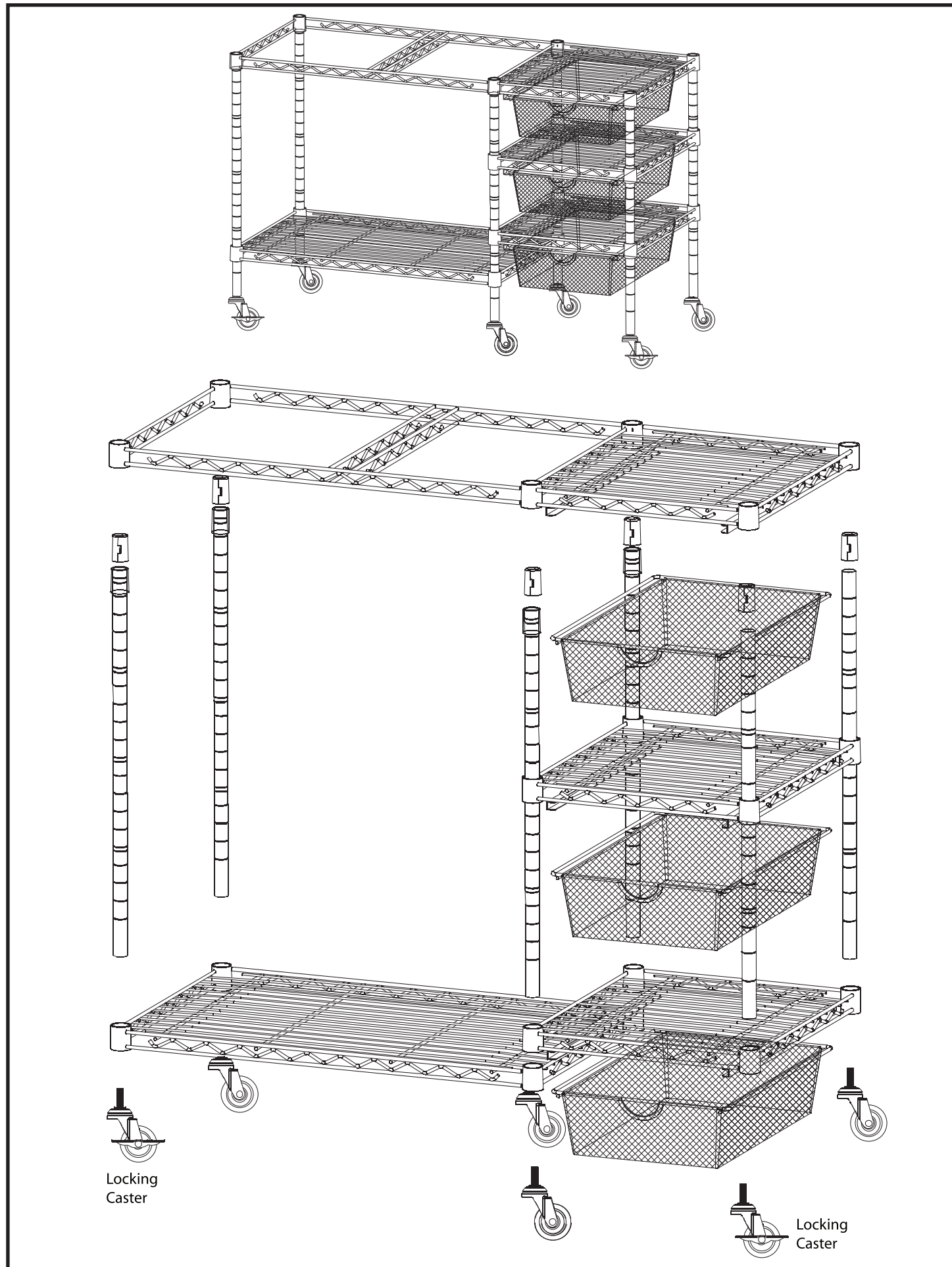

3) Large Bottom Shelf

Slide one leg through hole on each corner of bottom shelf, as shown.

Slide shelf over compression clip and press down firmly. Repeat for each of (4) legs.

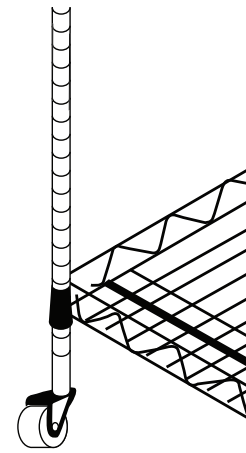
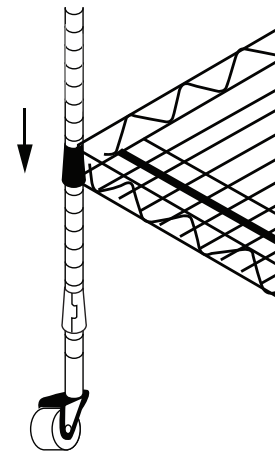

Assembly Tip:
You may want to use a soft rubber mallet to tap the shelves after you slide them over the compression clips.

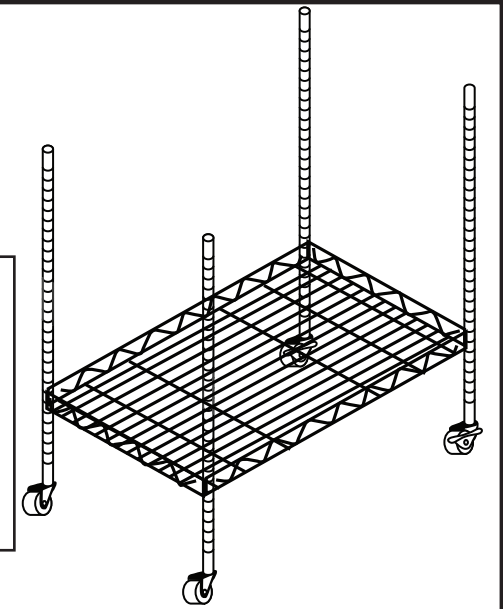

4) Small Shelves

Place compression clips at the desired height on assembled unit, as well as the remaining two legs. (Refer to Page 1 for Clip Installation). Slide shelf over two legs of assembled unit as well as the two remaining legs. Press firmly to ensure a tight fit. Repeat with second small shelf.

Note: To assure that shelves are level, verify that the compression clips are located around the same groove on each leg before sliding the shelves into place.

Note:
The drawer slides welded underneath the shelves have open fronts to accept the drawers, and closed backs to prevent the drawer from being pushed in too far. During assembly take care to position all shelves with the open fronts of the slides facing forward.

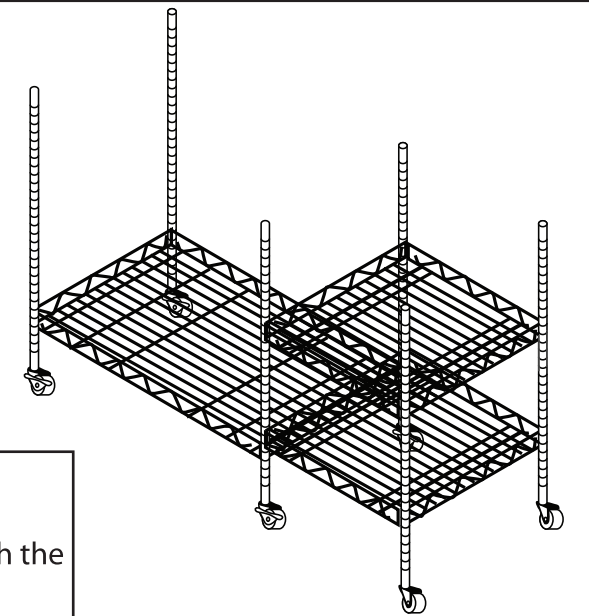

5) Top Shelf

Place clips at the top of each leg. (Refer to Page 1 for clip installation.) Slide the top shelf onto the clips. Press firmly to ensure a tight fit.

