

MANAGERIAL MID-BACK CHAIR

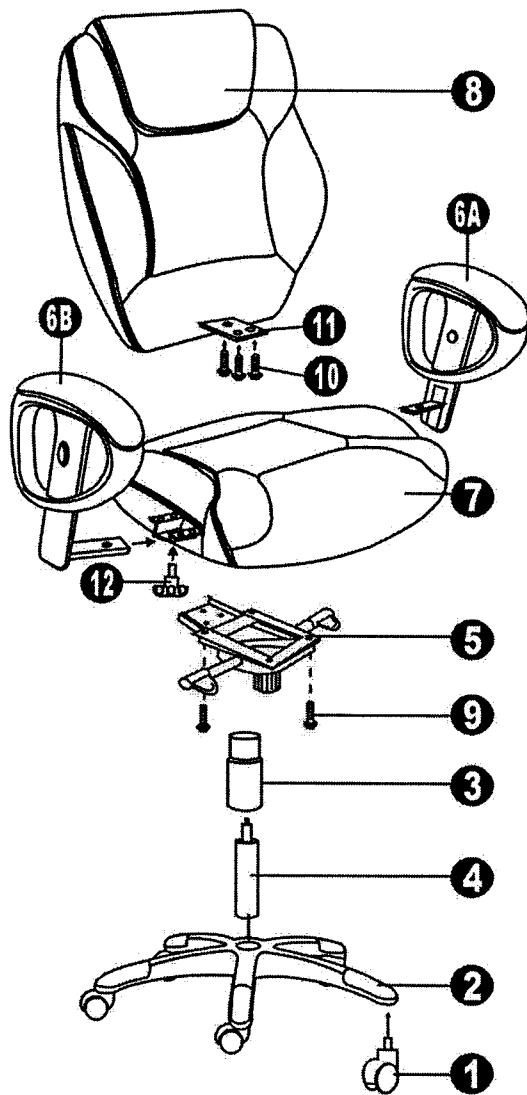

PARTS LIST

Part #	Description	Quantity
1.	Casters	5
2.	5 Star Base	1
3.	Telescoping Cover	1
4.	Gas Lift	1
5.	Seat Plate	1
6A.	Left Arm	1
6B.	Right Arm	1
7.	Seat Cushion	1
8.	Back Cushion	1
9.	Long Screws	4
10.	Short Screws	3
11.	Back Support Plate (already attached to the back cushion)	1
12.	Knobs	2
13.	Wrenches	2

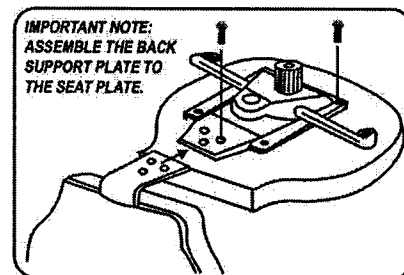

Diagram 1

ASSEMBLY INSTRUCTIONS

- A. Remove all parts from carton and separate them into part number groups as indicated above.
- B. To begin assembly, place 5 star base (2) upside down and insert casters (1) into bottom of base (2).
- C. Turn base (2) right side up on the floor and insert gas lift (4) into center hole on base (2).
- D. Place telescoping cover (3) over the gas lift (4) and rest it on the base (2).
- E. Attach seat plate (5) onto the underneath of seat cushion (7) (with front of seat plate facing front of seat cushion) by screwing long screws (9) into the seat plate (5) and **tighten screws.**
- F. Insert the back support plate (11) into the bracket of seat plate (5), line up the holes on both back support plate (11) & bracket of seat plate (5), secure with short screws (10) as shown in diagram 1 and **tighten screws.**
- G. Place the assembled chair on top of gas lift (4) and press down until fully engaged.

Item number: **UL330MBLK/UL330MBUR**

MANAGERIAL MID-BACK CHAIR

OPERATING INSTRUCTIONS

1. To Adjust Seat Height:

While seated, lean forward and reach under right side of the chair to find the lever. Push lever upward and raise your body up slightly to allow the chair to rise to the desired height. To lower the seat, push lever upward and apply weight downward on the seat. The chair will descend until the lever is released or the chair reaches the lowest position available.

2. To Operate Synchro Lockout:

Reach under left side of the chair to find the lever. Push lever upward to allow the chair to tilt backwards. To lock the back and seat in the positions you desire, turn lever downward. Once you want to release the synchro mechanism from the lock position, push the lever upward (when pushing the lever upward, apply more weight backward onto the back rest cushion and then release, the back rest cushion will return back to normal position.).

3. To Adjust Tension on The Tilt:

Reach under the front center of the chair, grasp the round knob and turn it clockwise to stiffen the tilt mechanism. Turn the knob counter - clockwise to loosen the tilt mechanism. Rotate the knob until the desired resistance is reached.

4. To Adjust Arm Height:

Press the buttons on the chair arms. Press the buttons to allow the arms to move up or down freely then release the buttons once the desired height is reached.

5. To Adjust Arm Width:

While seated, reach for the knobs underneath the arms located on bottom of seat cushion. Turn the knobs clockwise to loosen the width adjustment feature then turn the knobs counter - clockwise to tighten when you have reached your desired width.

CP-240 arm U.S. Patent D494,791S

CP-422 arm pad U.S. Patent D509,085S

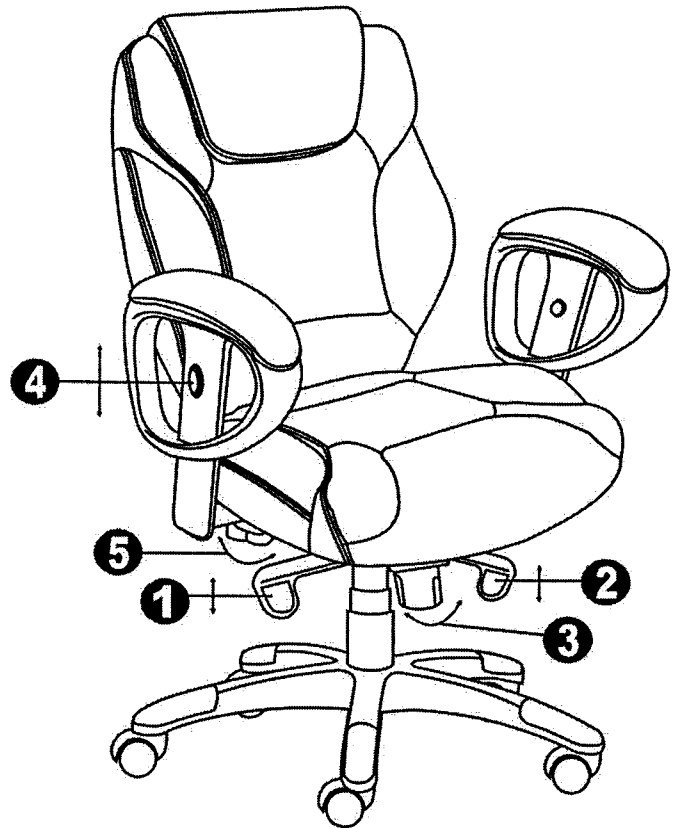

Tiffany Industries™

A MAYLINE GROUP COMPANY

619 N. Commerce, P.O. Box 728 Toll Free: 1-800-822-8037
Sheboygan, WI 53082-0728 FAX: 920-457-7388
On Line: www.mayline.com

Item number: **UL330MBLK/UL330MBUR**