

Carson-Dellosa's
**DOUBLE POCKET
 CHART STAND**

Directions for Assembly

1. Insert all four bottom crossbars (G) into one of the plastic wheel bases (A). Push the bars firmly into the insert. Lay wheel base on it's side with cross bars extending up.
2. Place the second wheel base (A) on the cross bars so the insert holes line-up with the cross bars. Firmly insert the bars into the holes. To secure the base, apply pressure to the wheel base, allowing for secure insertion of poles and set flat.
3. Locate the four large black rods (E). Insert the four large black rods (E) (extension end up) into the the plastic wheel base (A) and apply pressure.
4. Locate the two small black support rods (H). Attach the two small black support rods (H) to the extensions on the large black rods (E).
5. Locate the two plastic rod joiners (B). Slide the plastic rod joiners (B) onto the ends of the large black rods (E) with the latches facing out.
6. Locate the four curved silver rods (D). Attach the straight ends of the curved silver rods (D) to the rod joiners (B).
7. Locate the four right angle joiners (C). Attach the right angle joiners (C) to the curved ends of the silver rods (D).
8. Locate the the two straight silver rods (F) and the ten pocket chart rings (I). Attach one end of each straight silver rod (F) to the right angle joiners (C). Load the pocket chart rings (I) onto the straight silver rods through the center of each ring (F). Attach the other ends of the straight silver rods (F) to the opposite right angle joiners (C).

Step One
Step Two

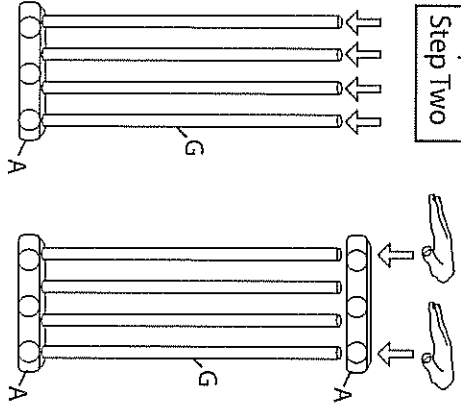

Step Three

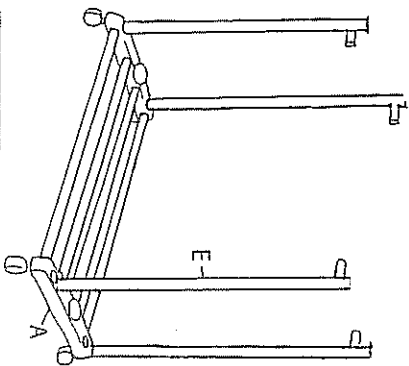

Step Four

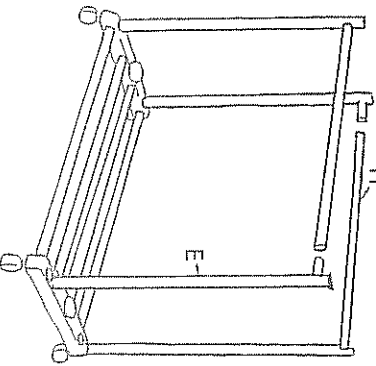

Step Five

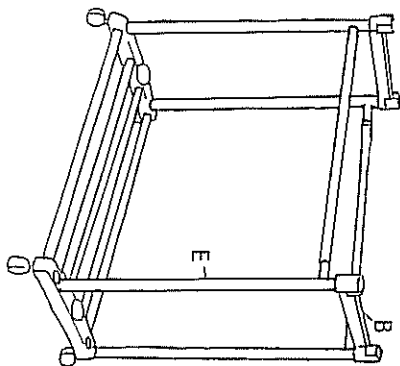

Step Six

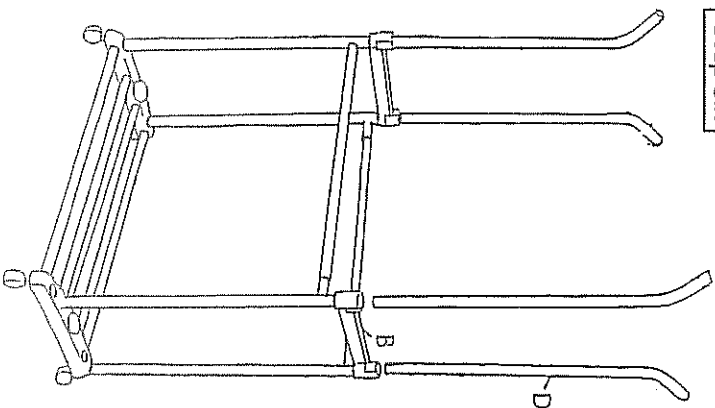

Step Seven

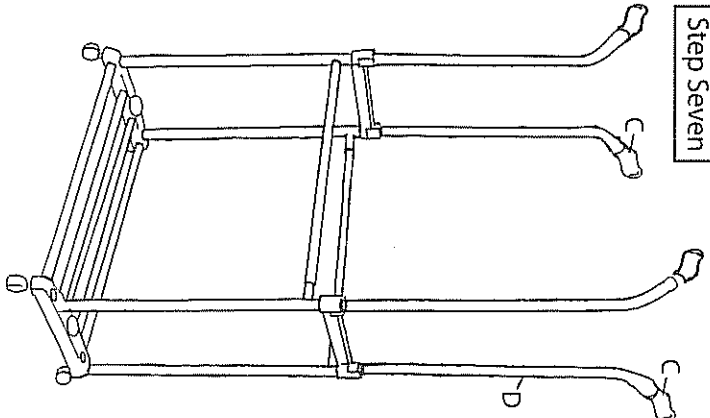

Step Eight

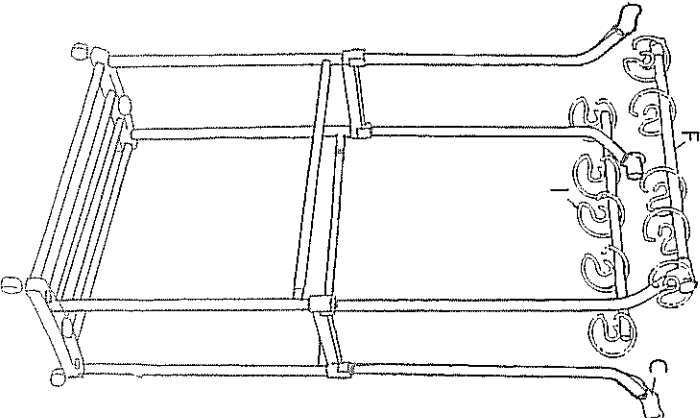

PARTS LIST

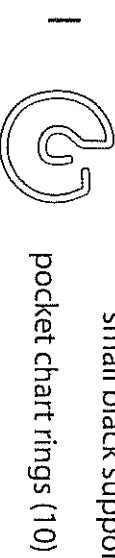
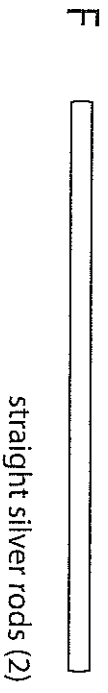
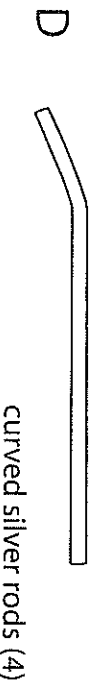
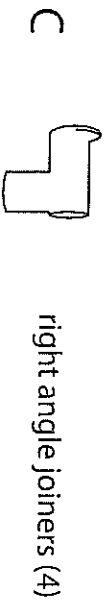
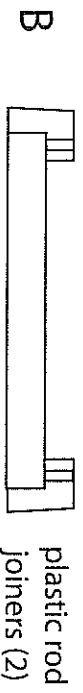
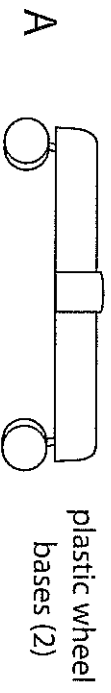

*Instructions on the other side