

# ASSEMBLY INSTRUCTIONS

## CSII DESK AND CREDENZA

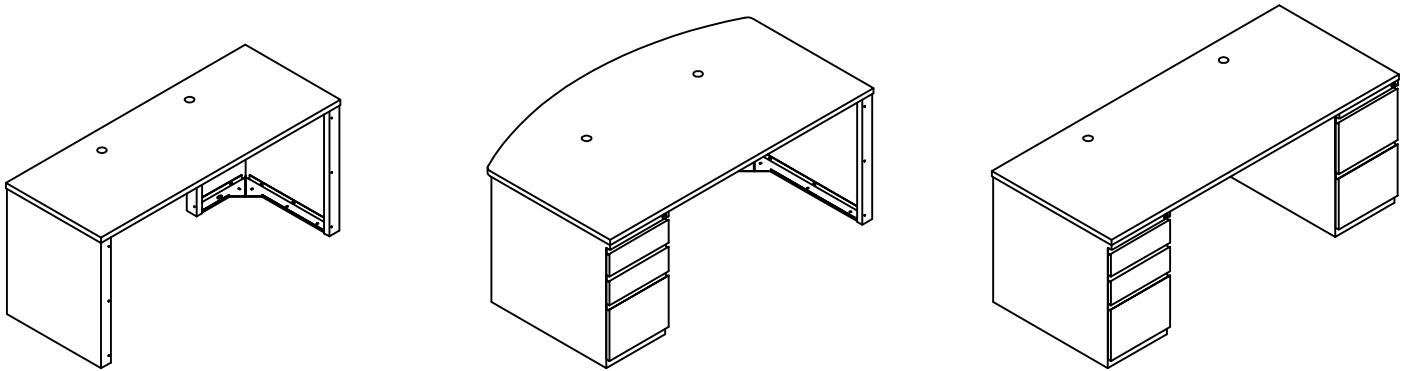









**NOTE:** Please count and inspect all pieces before disposing of any carton or packing materials.

**COMPONENTS:** When ordering components, specific color and/or size information may be required. Contact a Mayline Customer Service Representative. 1-800-822-8037

Item #	QTY.	DESCRIPTION	PART #
1	1	WORK SURFACE	CALL ~**
2	1	MODESTY PANEL	CALL ~**
3	0 / 1 / 2	LEG	CALL ~**
4	2 / 1 / 0	DRAWER PEDESTAL	CALL ~**
5	1	L.H. GUSSET	B7483**
6	1	R.H. GUSSET	B7482**

\*\* Denotes Color Code  
~~ Denotes Size

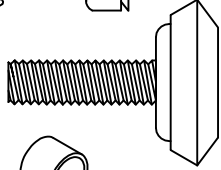
**HARDWARE BAG (PART No. A7618)** \* for individual item, order that part number

Item #	QTY	DESCRIPTION	PART #	
E1	26	#10 X 3/4 SCREW	X11*	 
E2	10	#10-24- X 3/8 SCREW	X147*	 
E3	10	#10-24 KEPS NUT	T2*	 
E4	4	GLIDE	Q444*	
E5	4	CABLE CLAMP	F191*	

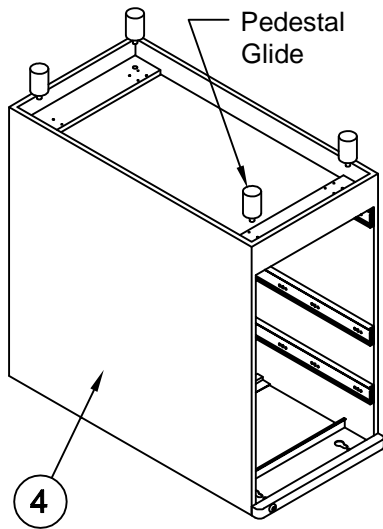

### Drawer Pedestal Assembly:

1. Remove the Pedestal (4) from carton.
2. Remove all drawers from the Pedestal by pulling drawers out to the full extent. Locate the drawer slide release tab on each drawer slide. Press **DOWN** on the Right tab and **LIFT** the Left tab. Pull drawer forward to remove.
3. Turn the Pedestal upside down and install four Glides into threaded holes on bottom of Pedestal.

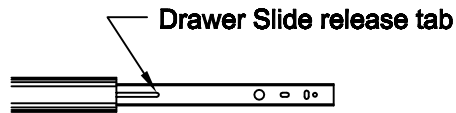

### Desk or Credenza Assembly:

**NOTE:** Shape, size, and accessories may vary but assembly procedure remains the same. Bow Front Desk with Pedestal is shown.

4. Place the Work Surface (1) face down onto a clean, protected surface.
5. Position Leg (3) approximately 3/16 from the edges and align the holes in the Leg with the pre-drilled holes in the Work Surface. Attach each Leg to Work Surface with seven Screws (E1). **DO NOT** tighten screws at this time.

For units equipped with a Drawer Pedestal (4):

Position Drawer Pedestal (4) approximately 3/16 from the edges and align the Pedestal holes with the pre-drilled holes in the Work Surface (**NOTE: DO NOT USE** keyhole slots). Attach the Pedestal to Work Surface with four Screws (E1) - two at the front and two at the rear. **DO NOT** tighten screws at this time.

6. **MODESY PANEL - DESK:** The Modesty Panel (2) may be positioned either flush or inset of the Leg or Drawer Pedestal. Select your desired location.

MODESTY PANEL - CREDENZA: The Modesty Panel (2) will be positioned flush with Legs or Drawer Pedestal.

Position the Modesty Panel (2) between the Legs (3) or Leg and Pedestal. Align the holes in the Panel with the pre-drilled holes in the Work Surface. Secure Panel with Screws (E1). **DO NOT** tighten screws at this time.

7. Attach the Modesty Panel (2) to each Leg (3) with three Screws (E2) and three KEPS Nuts (E3). Modesty Panel does not get attached to the Pedestal Unit.
8. Align the holes in the Gusset (5) and the holes in the Modesty Panel (2). Attach the Gusset to the Panel with two Screws (E2) and two KEPS Nuts (E3). Attach the Gusset to the Work Surface with two Screws (E1).
9. Tighten all screws at this time.
10. Install two Glides (E4) into each Leg.

Desk or Credenza Assembly:

NOTE: Shape, size, and accessories may vary but assembly procedure remains the same. Legs and Drawer Pedestals may be placed on Right **or** Left side.

Assemble as shown for LEFT HAND Pedestal

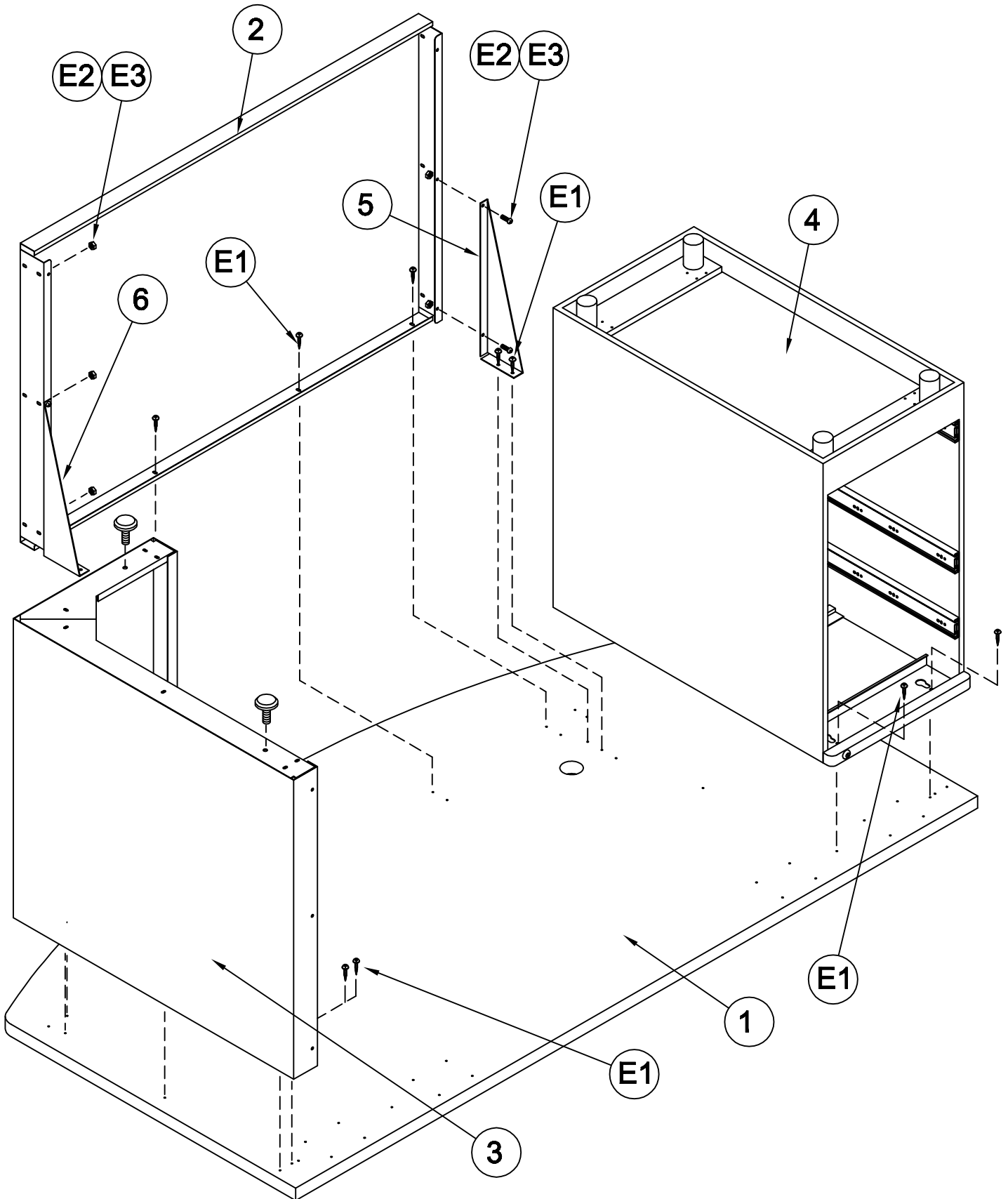

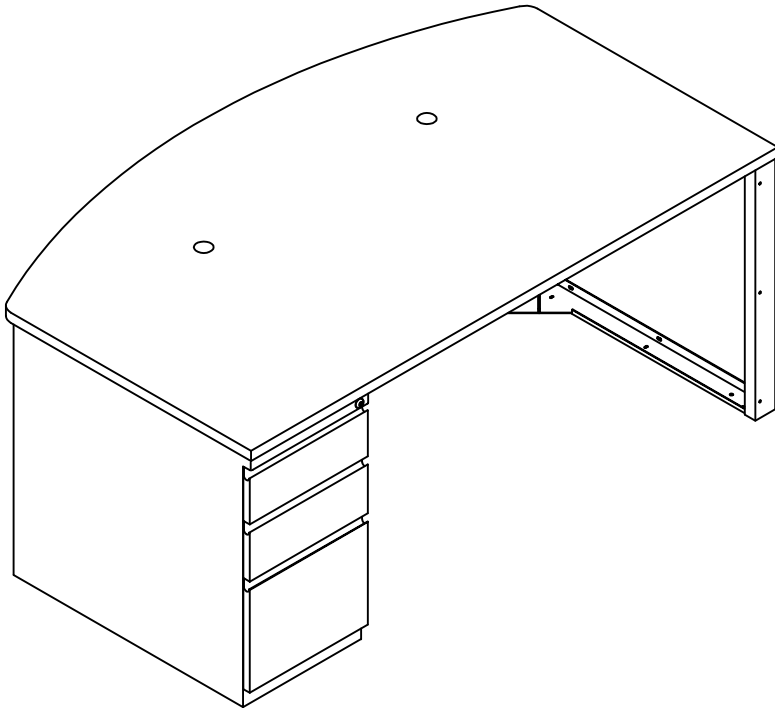

11. Place the assembled desk in the upright position. MAYLINE recommends that a minimum of two people perform this task.
12. Place the desk at the location where it will be used. MAYLINE recommends that a minimum of two people perform this task.
13. Level the assembly by adjusting the glides. If your assembly includes a Drawer Pedestal, adjust all four glides under that unit.
14. If your assembly includes a Drawer Pedestal, return all drawers to the pedestal at this time.
15. Four Cable Clamps (E5) are included to position cables away from work area. Attach the clamps to the Work Surface with one Screw (E1) per clamp.